



Instrument

This product may pose a risk if not operated properly. Please read the Instruction manual carefully and take time to become familiar with operating the instrument before using it. Please take particular note of the information on risks and dangers.

Instruction Manual CD





Non-liability:

Testo AG does not accept any responsibility for any damage caused by using this CD. In particular, no responsibility is accepted for personal injuries, material damage or financial losses arising as a direct result of using the CD.

This CD only contains computer data. It should not be played on an Audio CD player.

Gaps were left intentionally when numbering the chapters. Empty chapters are not relevant to the instrument described.

Navigation

- a Bookmark: Click on a bookmark to get to the required theme.
- b Print: Click on  to print a document or single pages (also refer to d).
- c Index: Click on  to search in the index.
- d Page numbers: Shows the page numbers relevant for printing.
- e Scroll up: Click on  to get to the top of the document.
- f Scroll down: Click on  to go down the document.
- g End: Click on  to end the program.

Further information on how to use the program can be found at **Help -> Reader Help.**

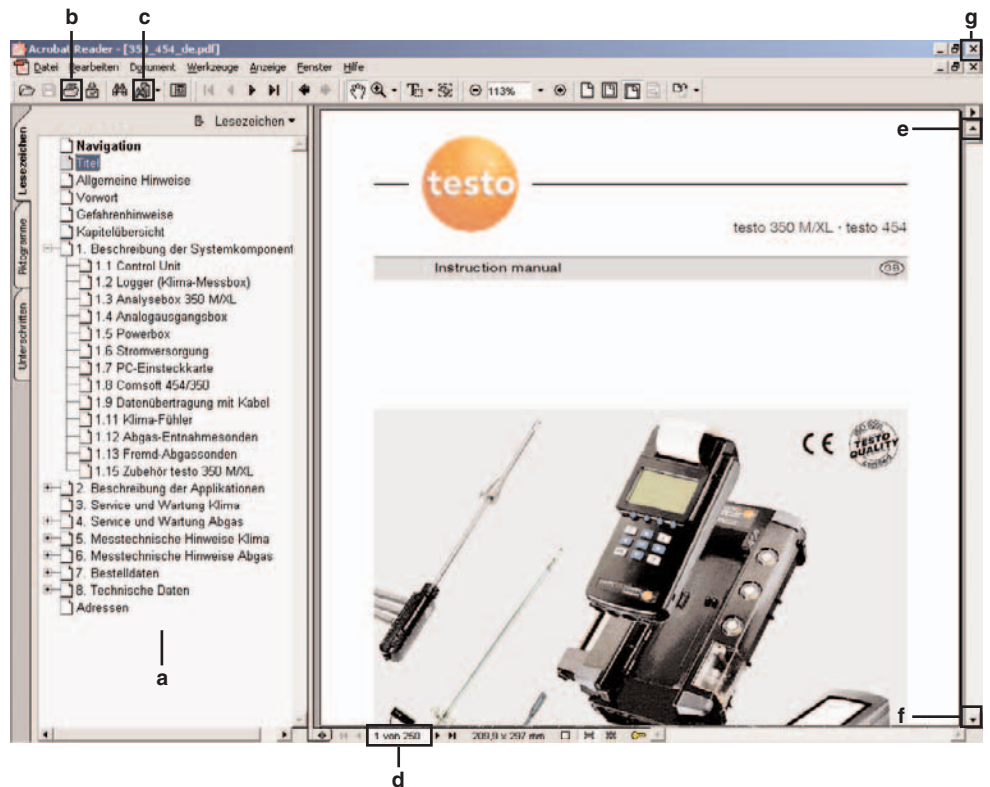

Dear Testo customer,

Your decision to purchase a measuring system from Testo was the right choice! Thousands of customers buy our high-quality products every year. There are at least 7 good reasons for this:

- Our price/performance ratio is good. Reliable quality at a fair price.
- Substantially extended warranty periods up to 3 years – depending on the model.
- We provide an optimum solution for your measuring tasks with over 40 years of professional experience.
- Our high quality standards are confirmed by the ISO 9001 certificate.
- Of course, our devices also bear the CE label required by the EU.
- Calibration certificates for all relevant parameters. Seminars, consulting and calibration on-site.
- We don't leave you on your own after your purchase. Our service guarantees rapid support.

As stated in the Certificate of Conformity, these instruments comply with the guidelines of 89/336/EEC.

With your testo 350/454 measuring system, you own a flexible system open to future applications which can vary in the extent of its operations and software according to the installed version.

The fundamental concept of the testo 350/454 system is to provide the experienced, professional technician with the right equipment to perform the measuring assignment.

The user must only have and install what they need for each task – no more and no less.

The consequence of this is the division of the fully equipped system into functional units. These can be operated individually or in almost any desired combination.

The smallest unit capable of making measurements is the control unit. Pressure measurement is integrated. Nearly any testo probe can be connected to the probe socket. Up to 6 channels are displayed simultaneously on the graphic display. Current readings can be either printed immediately or stored in the internal memory of the control unit. The location stored with the measurement data aids you in managing your data. In conjunction with the PC software, this makes it possible to plan regular visits and remains attached to the measurement data until archiving on a PC.

Depending on the main task, e.g. "flue gas analysis in industrial installations" or "industrial/ventilation/air conditioning measuring technology", the first step to a system is the connection of a flue gas analyser unit or a logger with four probe sockets.

An analyser box measures all necessary parameters of a combustion process. O₂, CO, CO₂, NO_x, SO₂... depending on the attachments, a logger with 4 probe sockets measures and stores the parameters depending on probe: temperature, humidity, pressure, velocity and other values of interest in building installations.

Several of these system components can be combined with each other. They provide and store data jointly, either plugged together directly or separated and connected together by the testo databus.

The measurement data is visualised by the control unit. Alternatively, all measuring channels can be displayed online by a PC. This also evaluates, documents and archives the stored measurement sequences with variable measurement durations and any desired combination of channels.

Depending on its equipping, a system of this kind quickly issues the readings of 20, 50 or more channels up to once per second and is therefore able to generate an enormous volume of data.

For this reason, particular value was placed on the capability to discern individual measuring channels beyond their physical units and to assign specific information to the measurement logs at their origins.

In addition to the physical unit, a 4-character designation can be assigned to each channel.

Each unit can be assigned with an additional, user-defined name.

Stored data is linked to a 20-character, alphanumeric location. A further info field is assigned to this.

Used in judicious combinations, these names ensure that raw data obtained from several channels remain identifiable on-site during the measurement. They are also a necessity for the assessment, management and archiving of data on the PC.

The connection to the PC is made either by the testo databus and a PCMCIA plug-in card or by the control unit and an RS-232 line connected to the COM port of your PC.

One or more powerboxes can be connected as accessories to the measuring system. These increase the running time of the measuring system when operating off the mains and supply energy to the testo data bus, which is galvanically isolated from the instrumentation.

The analog output box is a further accessory. With this, up to 6 measuring channels can be arbitrarily scaled and issued at a 4...20mA output.

This concludes the summary of the features of this system, making it easier to familiarise yourself with its functions and also the operating instructions. Please tick the system components that you use on the first page. You will then receive the information, descriptions and text which exactly match the constellation of your system.

testo 350 M/XL precautions			
	Persons	System	Instrument
Power supply Do not ever disrupt the PE conductor either inside or outside of the instrument! Check the ID label to ensure that the model, mains voltage and output coincide with the actual conditions!	X		X
Disposing of the measuring cells There are nominal amounts of concentrated acid in the measuring cells. Therefore, dispose of as hazardous waste! Improper handling is hazardous!	X		
Storing the measuring instrument Never store the measuring instrument in rooms with solvents. Doing so runs the risk of destroying the measuring cells! Ensure that you observe the specified storage, transport and operating temperatures!			X
Rechargeable battery Fully recharge the battery before conducting the initial measurement and after the instrument has gone unused for several days. Recharge the battery every 4 weeks after longer periods of inoperation. The testo rechargeable battery pack for the Control Unit and logger should be inserted so that the label faces outward. Otherwise, there is the danger of a short circuit or reverse polarity should the isolation jacket become damaged.			X
Operating the probe When removing the probe from the flue, check that the probe is hot!	X		
Condensate outlet: Aggressive condensate (acid) exits the condensate outlet. If the corresponding drainage facility (e.g. hose) is not attached, there is a hazard for persons and property!	X		X
Service and maintenance The power plug must always be pulled before opening the housing. Danger of electric shock! Access the instrument internals must only be done by authorised personnel!	X	X	X
Non-permissible measurements Explosive or ignitable gas mixtures as well as gases that form ignitable mixtures when exposed to air must not be measured with the above-listed instruments!	X		
Test gas pressure A maximum of 50 mbar is permissible. Higher pressures increase the risk of destroying the gas sensors! Additionally, test gas must only be used in well-ventilated rooms!	X		X
Cleaning the instruments Avoid the penetration of water into the instrument at all costs!			X
Differential pressure probe When conducting measurements, observe the permissible measuring ranges; exceeding tolerance leads to destruction of the sensor!			X
Condensation Avoid exposing the instrument and instrument electronics to condensation.			X
Measurement in closed rooms Ensure that the room is sufficiently ventilated if flue gas concentrations are high. Otherwise there is a risk of poisoning.	X		

testo 454 precautions			
	Persons	System	Instrument
1 Alarm contact The alarm contact must not be integrated into safety-related processes, as the contact poses a hazard for persons and property, the system and the instrument.	X		
2 Analog output The analog outputs must not be used to control/regulate safety-related processes. They are designed to supply data to recorders, etc. Danger of system malfunction! A total of 12 cover plugs is supplied for the analog outputs (banana sockets). The EMC conformity certificate is valid only if the plugs are used on the non-assigned banana sockets.	X	X	
3 Logger, powerbox Operating loggers and powerboxes beyond their specified limits can lead to expulsion of hydrogen (H ₂) from the battery pack. Danger of explosion!	X		
4 Entire system Do not connect any part of the system to live objects (i.e. supplied with voltage) for measurement. Danger of electrical shock!	X		
Protect system from overvoltage.			X
5 CO measurement Ensure that there is sufficient ventilation when measuring toxic gases (CO). Danger of poisoning!	X		
6 Power supply to entire system Always ensure that the entire system is supplied with sufficient power (fully charged batteries/rechargeable batteries, mains unit). Danger of the entire system becoming unstable.			X
7 EMC Exceptionally high amounts of electromagnetic interference can lead to deviations in reading accuracy that no longer conform to standard. Danger with connected analog/switch outputs! The plug socket should have a protected earth conductor connected. The temperature display with control unit and separate probe can jump by up to 2°C in the case of a thermocouple with earth contact in connection with a switched-mode power supply.	X	X	
8 Process security for analog monitoring Very dynamic signals can overload processes. In order to stabilise process security for systems with dynamic signals we recommend observing Namur recommendation NE43, which makes specifications regarding signal conditions. Danger of overloading systems!		X	
9 Condensation Avoid exposing the instrument and instrument electronics to condensation.			X

Preface

Notes on the instruction manual

1. Description of the system components

- 1.1 Control Unit
- 1.2 Logger
- 1.3 Analyser box 350 M/XL
- 1.4 Analog output box
- 1.5 Powerbox
- 1.6 Power supply
- 1.7 PC plug-in card / Comsoft 454/350
- 1.8 Comsoft 454/350
- 1.9 testo data bus
- 1.10 System examples using the testo 454 logger
- 1.11 HVAC probes
- 1.12 Flue gas sampling probes
- 1.13 Flue gas probes from other manufacturers
- 1.15 testo 350 M/XL accessories

2. Description of the applications

- 2.1 Spot measurement of HVAC with the Control Unit
- 2.2 Measuring and storing with the Control Unit and a logger
- 2.3 Spot measurement of HVAC with PC plug-in card
- 2.4 Spot measurement of flue gas with base system – Control Unit
- 2.8 Long-term measurement of HVAC with the Control Unit
- 2.9 Long-term measurement of HVAC with the Control Unit and logger
- 2.10 Long-term measurement of HVAC with PC plug-in card
- 2.12 Long-term measurement of several boxes with PC plug-in card
- 2.13 Long-term measurement of flue gas with the base system – Control Unit
- 2.14 Long-term measurement of flue gas with the base system – testo data bus
- 2.19 Online PC RS-232 – Control Unit
- 2.21 Online PC RS-232 with one or more loggers
- 2.22 Online PC RS-232 – base system, flue gas
- 2.23 Online PC RS-232 – operation with one or more analyser boxes

4. Service and maintenance, flue gas

- 4.1 Maintenance and service, flue gas analyser

5. Instrumentation notes, ventilation/air conditioning

- 5.1 Changing units
- 5.2 Entering parameters
- 5.3 Pitot tube factor
- 5.4 Adjusting the smoothing
- 5.5 Surface allowance

6. Instrumentation notes, flue gas

- 6.1 Principles of calculations
- 6.2 Suggestion for measuring and rinsing cycles of toxic sensors (for long-term measurements)

- 7. Ordering data**
- 7.1 testo 350 M/XL
- 7.2 testo 454

- 8. Technical data**
- 8.1 Logger
- 8.2 Analyser box

Addresses

- 1. Description of the system components**
- 1.1 Control Unit
- 1.2 Logger
- 1.3 Analyser box 350 M/XL
- 1.4 Analog output box
- 1.5 Powerbox
- 1.6 Power supply
- 1.7 PC plug-in card / Comsoft 454/350
- 1.8 Comsoft 454/350
- 1.9 testo databus
- 1.10 System examples using the testo 454 logger
- 1.11 HVAC probes
- 1.12 Flue gas sampling probes
- 1.13 Flue gas probes from other manufacturers
- 1.15 testo 350 M/XL accessories

- 1.1. Control Unit**
- 1.1.1 General description**
- 1.1.2 Initial operation**
- 1.1.3 Operation**
 - 1.1.3.1 Controls
 - 1.1.3.2 Entering numbers and letters
 - 1.1.3.3 Control unit function keys
- 1.1.4 Display**
 - 1.1.4.1 General description
 - 1.1.4.2 Display lighting
 - 1.1.4.3 Zooming readings
- 1.1.5 Control unit menu guide**
- 1.1.6 System settings**
 - 1.1.6.1 Setting the date/time
 - 1.1.6.2 Setting the language
 - 1.1.6.3 Setting auto-off
 - 1.1.6.4 Displaying the address
 - 1.1.6.5 Renaming system components
 - 1.1.6.6 Touchscreen option: Calibrating the touchscreen
 - 1.1.6.7 Password protection
- 1.1.7 Printing**
 - 1.1.7.1 Initial operation of printer
 - 1.1.7.2 Printing readings
 - 1.1.7.3 Printing saved readings
 - 1.1.7.4 Printer settings
- 1.1.8 Differential pressure measurement**
 - 1.1.8.1 Setting the measuring range
 - 1.1.8.2 Differential pressure measurement
 - 1.1.8.3 Showing/Hiding the integrated differential pressure sensor
- 1.1.9 Factory settings**
 - 1.1.9.1 Resetting factory settings
- 1.1.10 Location management**
- 1.1.11 Printing locations**
- 1.1.12 Measuring functions**
 - 1.1.12.1 Displaying minimum and maximum values
 - 1.1.12.2 Holding current readings
 - 1.1.12.3 Calculating the mean

1. Description of the system components

1.1 Control unit 1.1.1 General description



The control unit is a portable measuring instrument for spot checks and measurements on site. It is equipped with a probe socket and an integrated differential pressure probe.

A comprehensive range of probes is available for the probe socket for the accurate measurement of temperature, humidity, velocity, turbulence, pressure, rpm, current and voltage. Up to 6 measuring channels can be shown simultaneously on the graphic display.

The control unit is operated using the keypad and a probe-dependent menu guidance system. Touch-pen operation is also optionally available.

Frequently used functions are executed directly with the function keys. The current allocation of the four function keys is indicated in the function bar of the display.

The system bar provides additional information such as operating display, the current location, system configuration and the page selection for the reading display. The display lighting makes it possible to work under difficult light conditions.

Up to 250,000 readings are saved for the selected location and documentation can be made on site with the integrated printer.

This measurement data can be transferred to a PC via the serial interface. You can analyse, document and archive this data with the ComSoft 3 software.

The control unit can be supplemented by 4 further probe sockets by a simple plug-on logger (see Chapter 1.2). The maximum number of readings is increased by the integrated memory of

the logger by 250,000 readings per logger. In combination with the testo 350 X/XL flue gas analyser box, the control unit constitutes a measuring instrument for the simple measurement of complex thermal processes.

Readings are acquired simultaneously at several locations by decentralised loggers and/or flue gas analyser boxes. The data is transferred to the control unit through the Testo databus. The control unit thereby undertakes the control of the measuring system.

1. Description of the system components

1.1 Control unit 1.1.2 Initial operation

Switching on

Insert the supplied batteries in the control unit or use an alternative power supply (see Chap. 1.6 for further information) and switch on the control unit with .

After the device version has been displayed, the measurement menu appears.

Caution!

**The probe is detected only when the control unit is switched on.
If you change the probe, the control unit must be switched on again.**

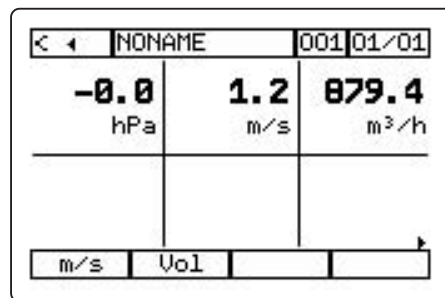

< ←	NONAME	001 01/01
-0.0 hPa	1.2 m/s	879.4 m ³ /h
m/s	Vol	

Switching off

The device is switched off by pressing  again.

The shut-off procedure can be interrupted by pressing function key , which then returns to the reading display.

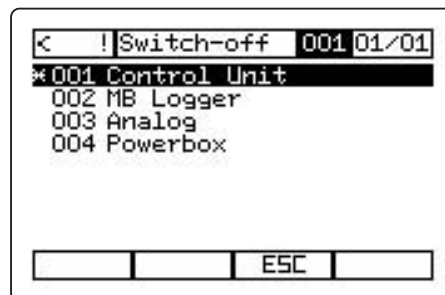

<	!Switch-off	001 01/01
*001 Control Unit		
002 MB Logger		
003 Analog		
004 Powerbox		
	ESC	

1. Description of the system components

1.1 Control unit 1.1.3 Operation

1.1.3.1 Controls

The device is switched on and off with the **I/O button**.



With the **menu key**, you can exit the reading display to the main menu.

This stops the updating of the reading display.

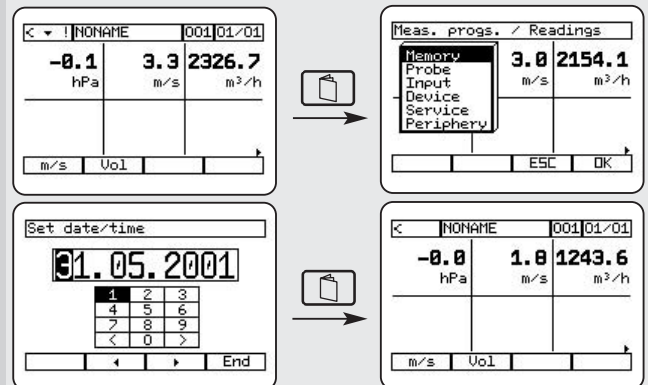

If you press the **menu key** in an input dialogue, this will return you directly to the reading display. The entered values are saved automatically.

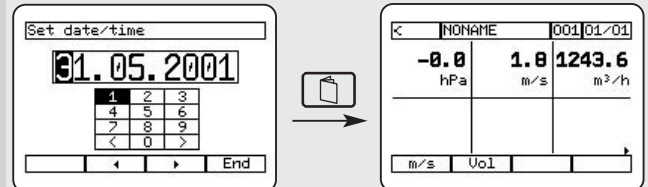

With the **ESC** key, you can terminate selected procedures or a chosen selection and exit submenus. When you exit a submenu, you will always move one menu window backwards until you reach the reading display.



You can access the current system configuration from the reading display using the **OK** key. The system configuration lists the control unit and all other connected components.

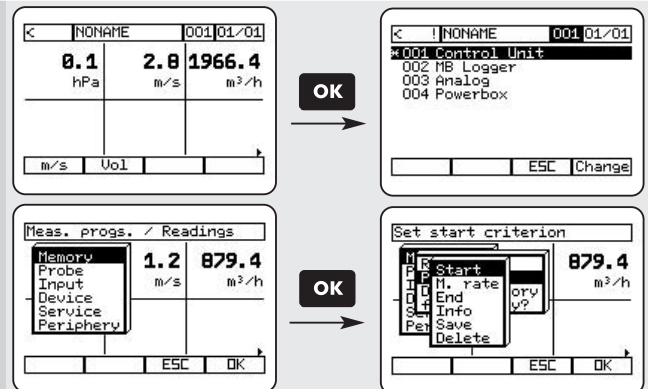

In the menu selection and in input dialogues, you can use the **OK** key to select menu items or to confirm alphabetical or numeric entries.

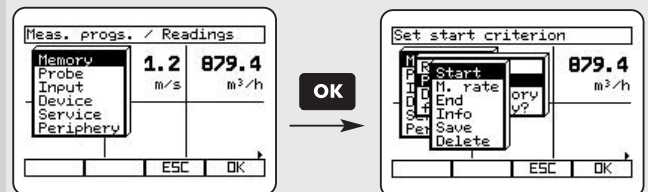

You can navigate in the input dialogues and menus with the **cursor keys**.

If there are more than six readings in the reading display, the readings are indicated on several pages, e.g. 01/02 in the page list of the readings means: Displaying page 1 of 2 pages of readings. You can browse backwards and forwards through the reading windows with the **up and down cursor keys**.

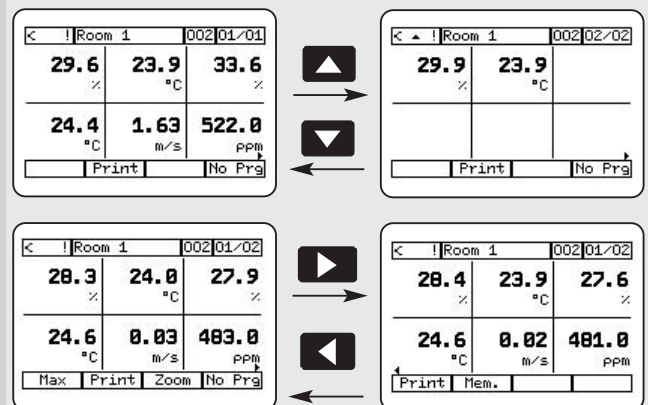

Also between the pages of all the instruments connected if **All devices** is activated in the control unit at **Device** --> **Configuration** --> **Device scroll**.

If more than four function keys are assigned, an arrow symbol pointing left or right appears in the function bar. When the **right or left cursor key** is pressed, these additional functions are displayed and can be activated with the function key.

The **lighting key** switches the display lighting on/off.



The **function keys** allow the rapid execution of device and measuring functions. The function bar indicates the significance of the individual function keys. Their effects can change according to the menu. The description of the function keys changes accordingly on the display.

The function bar can be assigned as desired to all functions of the function menu. (see Chap. 1.1.3.3)

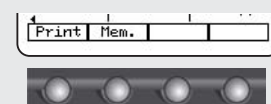

1. Description of the system components

1.1 Control unit 1.1.3 Operation

1.1.3.2 Input dialogues

Entering numbers and letters

When you are requested to enter letters or numbers, the letter/number matrix shown at the side appears on the display of the control unit.

Use the cursor keys to navigate in the matrix and choose the numbers or letters. The chosen symbol is accepted with .

The function keys are assigned as follows:

1. Switches between upper/lower case and symbols.
2. Delete (backspace)
3. Space
4. Accepts the entry and exits the input dialogue.

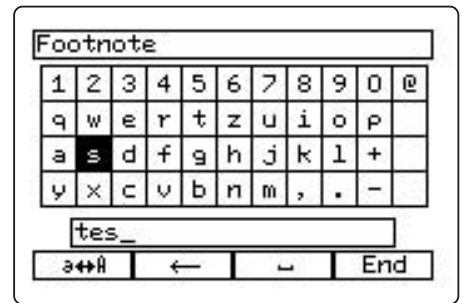

Entering parameters

When you are requested to enter parameters, the number matrix shown at the side appears on the display of the control unit.

Use the cursor keys to navigate in the matrix and choose the numbers or letters. The chosen symbol is accepted with .

The function keys are assigned as follows:

1. Uses the current reading of the connected probe for the entry.
2. Delete (backspace)
3. Applies the already saved parameter.
4. Accepts the entry and exits the matrix.

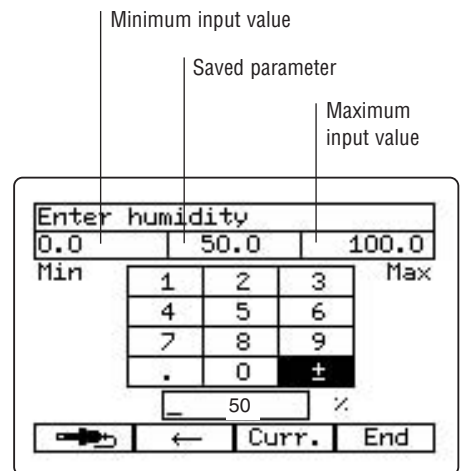

Caution!



The plausibility of the entry is only verified after the function key has been pressed.



1. Description of the system components

1.1 Control unit 1.1.3 Operation



1.1.3.3 Control unit function keys

Assigning a function key

Press menu key , release menu key  and then immediately press the function key to be assigned.

A selection list of the possible functions appears. Select the function with   and confirm with . The function key is then assigned.

Reversing the assignment

Press menu key , release menu key  and then immediately press the defined function key.

Confirm empty field in the selection list by pressing . The assignment is cancelled. The function key is unassigned.

Function key assignment	
Free function key (reverses assignment)	<input type="text"/>
“Zoom” readings	<input type="button" value="Zoom"/>
“Hold” current readings	<input type="button" value="Hold"/>
Display “Max” values since switching on	<input type="button" value="Max"/>
Display “Min” values since switching on	<input type="button" value="Min"/>
Calculate “Mean”	<input type="button" value="Mean"/>
Activate “Vol” volume flow measurement (with a velocity or differential pressure probe or integrated differential pressure probe)	<input type="button" value="Vol"/>
Activate/deactivate velocity measurement (with external differential pressure probe or for the integrated differential pressure probe) with “m/s”	<input type="button" value="m/s"/>
Measuring range 40 hPa for integrated differential pressure probe	<input type="button" value="dP1"/>
Measuring range 200 hPa for integrated differential pressure probe	<input type="button" value="dP2"/>
Zero pressure probe at freely assignable probe socket (with connected differential pressure probe)	<input type="button" value="PExt=0"/>
Zero the CO probe	<input type="button" value="ppm=0"/>
Start/stop measuring program	<input type="button" value="Start"/> <input type="button" value="Stop"/>
Determine system configuration	<input type="button" value="Search"/>
Save the readings	<input type="button" value="Mem"/>
Print the readings	<input type="button" value="Print"/>
Printer line feed	<input type="button" value="LF Pr"/>
Turbulence calculation (with connected turbulence probe)	<input type="button" value="Turb"/>

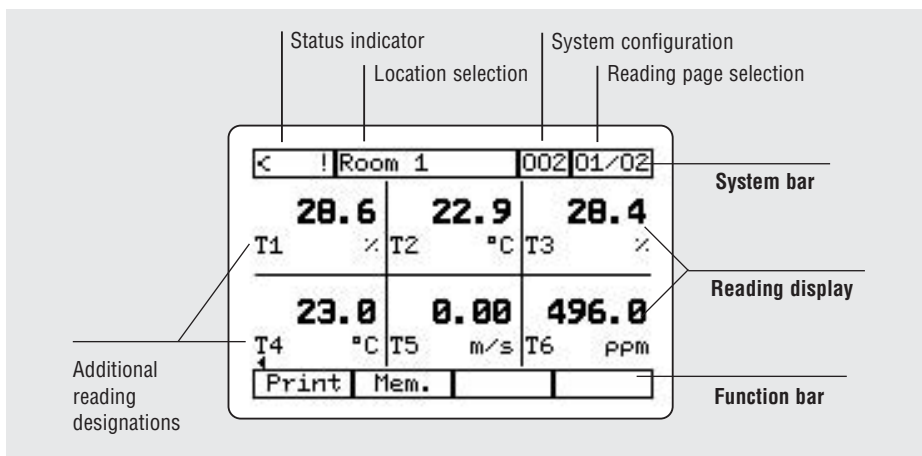

1.1.4.1 General description



System bar

Status indicator

The status indicator graphically indicates the current mode of the device; e.g. whether a measuring program is running or if the device is working on a mains supply. The following displays are possible:

- | | | | |
|---|--|---|-----------------------------|
|  | Battery warning |  | Measuring program activated |
|  | Mains operation |  | Measuring program running |
|  | Search for components on the Testo databus |  | Error message |

Location selection

The location list can be accessed by pressing **OK** and then **◀**. An overview of the saved locations and directories is then provided. Location management, see Chap. 1.1.10.

System configuration

After **OK** has been pressed in the reading display, the system configuration page appears. The control unit and all connected components (loggers, flue gas analyser box, analog output box, powerbox) are displayed.

Reading page

Displays the current page of the readings: e.g. 01/02 means that page 1 of 2 pages of readings for the selected components are displayed. The reading page can be accessed by pressing **OK** and then **▶**. It is possible to browse to the next page of readings.

Using **▲** **▼** you can scroll between the pages or in all the connected instruments, if set up (see 1.1-4).

Reading display

6 readings per window are displayed in the **reading display**.

Three readings in large print with the **zoom function** (with function key). Additional designations for the units of readings are possible by software using the PC, but cannot be entered locally on the control unit.

Function bar

4 function keys are located beneath the display.



The functions are indicated on the display above the keys. A small arrow on the left or right side indicates further functions which can be reached by pressing the keys **▶** or **◀**.

1. Description of the system components

1.1 Control unit 1.1.4 Display

1.1.4.2 Display lighting

On/off

The display lighting is switched on/off via the  key. After switching on, the display lighting must be activated by pressing the  key.

Automatic

The display lighting default setting is on when the control unit is switched on. The display lighting is switched off automatically after 3 minutes. If you press the  key, the display lighting remains on for a further 3 minutes.

Note

The display lighting reduces the running time of the control unit when in battery operation. Use the display lighting only when needed.

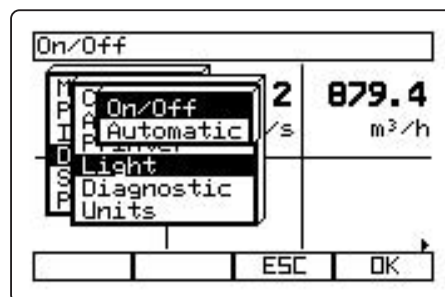
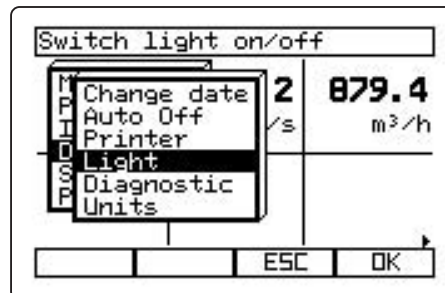
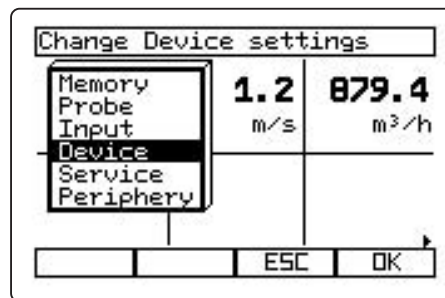

1. Description of the system components

1.1 Control unit

1.1.4 Display

1.1.4.3 Zooming readings

Assign a function key with the **Zoom** key.
(See Chap. 1.1.3.3, "Control unit function key assignment")

Press **Zoom**. Up to three readings are then shown in the reading display.

If you press **Zoom** again, the reading display appears with a maximum of six readings.

If the display is zoomed with more than three readings, the readings are indicated on several pages.

Display of the current page of readings: e.g. 01/02 means displaying page 1 of 2 pages of readings.

The reading page can be accessed by pressing **OK** and then **▶**. It is possible to browse to the next page of readings (with the touchpen). It is possible to browse through the pages of the reading display with the **▲** **▼** keys (keypad control).

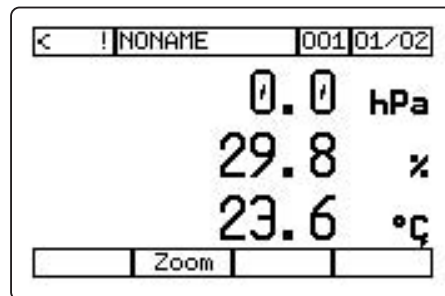
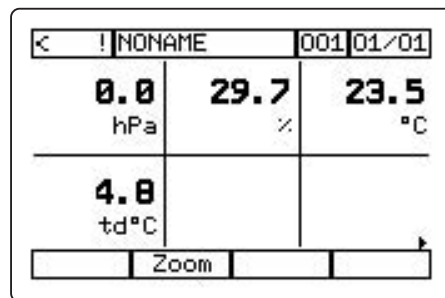

1. Description of the system components

1.1 Control unit 1.1.5 Control unit menu guide

Depending on the instrument configuration, your menu may differ from the menu described below.

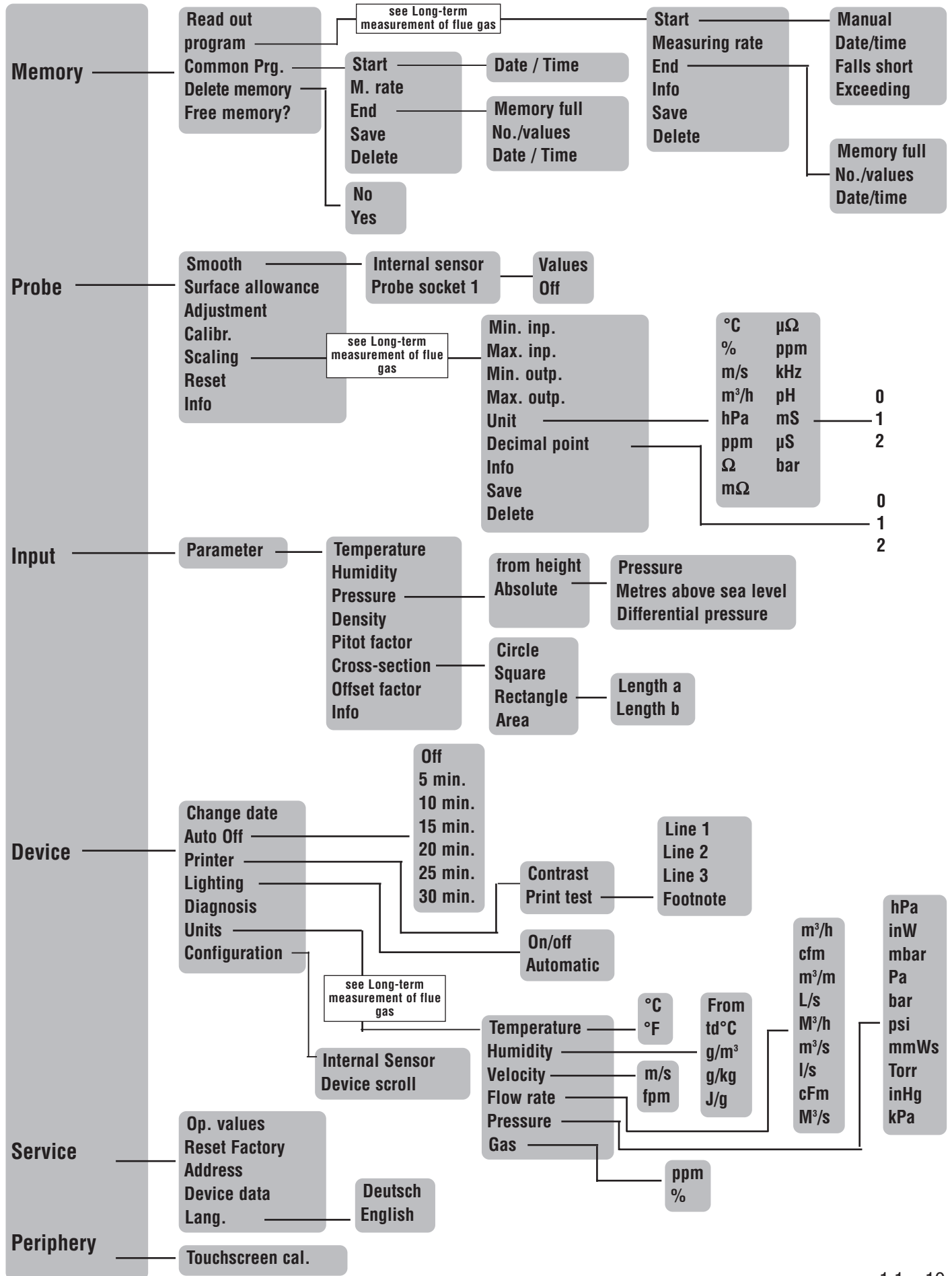







1. Description of the system components



1.1 Control unit 1.1.6 System settings

1.1.6.1 Setting the date/time

Select menu key  -> **Device** -> **Change date**.
Confirm with key .

With **Change**, you can access the settings for either the date or the time (depending on the position of the bar, which can be changed with  or .

It is possible to navigate in the input field as for numeric entries with    . The selected value is inserted with . The function keys with arrows are used to move to the correct digit of the date or time. The date/time comes into effect when **End** is activated.

If a measuring program is active, the date and time entries are locked. Instead of the input dialog, the message **Meas. program active** appears. Return to the reading display with  or .

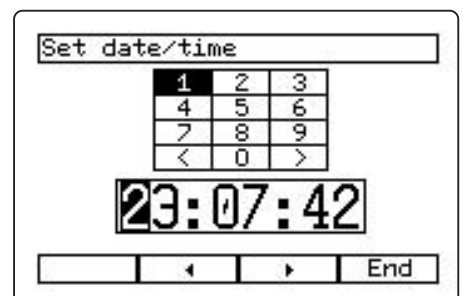
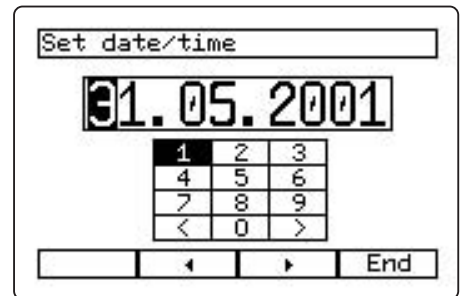
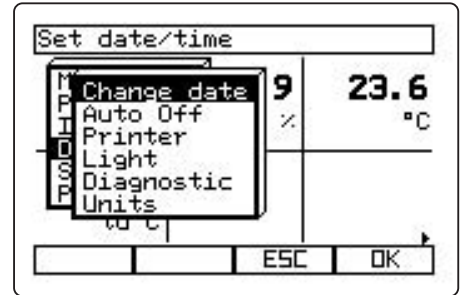
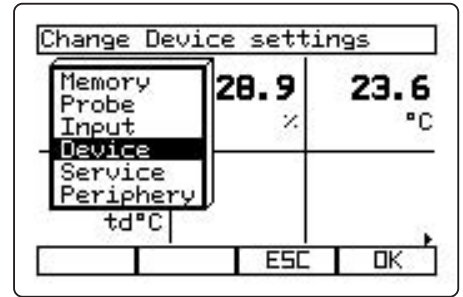

1. Description of the system components

1.1 Control unit 1.1.6 System settings

1.1.6.2 Setting the language

Select menu key  -> menu item **Service** -> menu item **Lang.**

The selected language is displayed immediately.

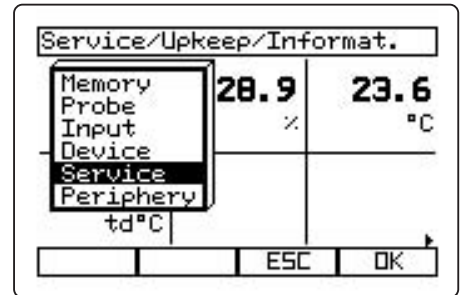
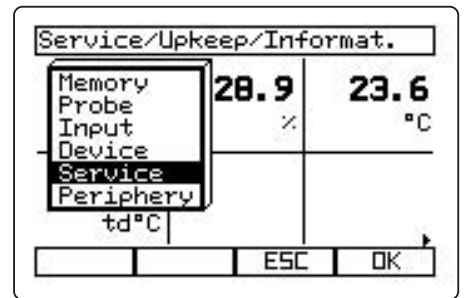

1. Description of the system components

1.1 Control unit 1.1.6 System settings

1.1.6.3 Setting the auto-off



The auto-off makes it possible to set the control unit to switch itself off automatically. The time before the shut-off procedure occurs ("Auto Off" time) can be chosen.



 -> **Device** -> Auto Off

Select the menu item **Auto Off** with  or  and press .

A pull-down menu appears with the entries:

Off, **5 min.**, **10 min.**, **15 min.**, **20 min.**, **25 min.** and **30 min.**

Select the desired time for the automatic shut-off of the control unit with  or  and press . The chosen Auto Off time is accepted.

The selection can be closed with  and . The control unit is switched off automatically after the chosen time.

If **Off** is selected, the control unit can only be switched off by .

If a measurement program is running with a measuring cycle longer than the Auto Off time, the device goes into sleep mode after the Auto Off time has expired and is reactivated for the chosen measuring cycle.

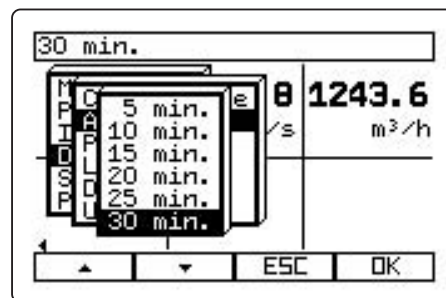
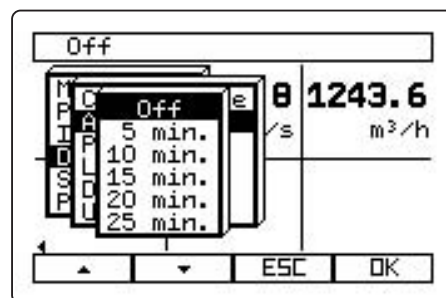
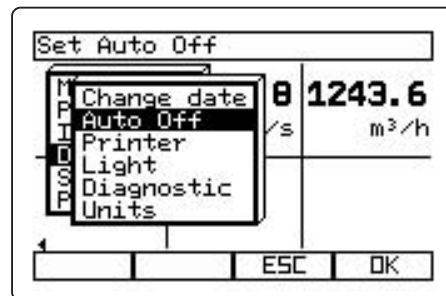
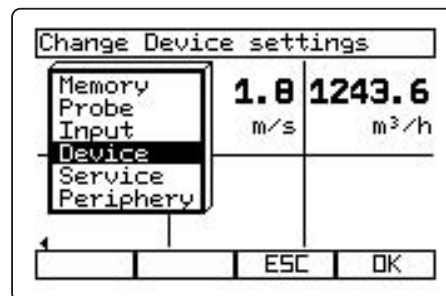

1. Description of the system components

1.1 Control unit 1.1.6 System settings

1.1.6.4 Displaying the address

Select  → **Service** → **Address**.



The customer's address is displayed.

The mask can be closed with  or  and the device returns to the input menu.

It is only possible to change the data with the PC software.



1.1.6.5 Renaming system components

- Press  for system configuration.
- Mark the desired components with the cursor keys  .
- Press function key **Change**.
- Enter the name of the component in the input dialogue box.



1. Description of the system components

1.1 Control unit 1.1.6 System settings

1.1.6.6 Touchscreen option: Calibrating the touchscreen

If you have purchased the touchscreen option together with your control unit, it may be necessary to recalibrate the touchscreen.

This calibrates certain positions of the display to the entry position with the touchpen, i.e. the position information with the pen and the information on the display are aligned with each other.

Press the  key after switching on the control unit. Then choose **Periphery** → **Touchscreen cal.** in the main menu and confirm with **OK**.

The screen window with the first calibration point then appears. Press the designated point with the supplied touchpen for the first calibration point.

Proceed in the same fashion for the second calibration point at the lower right edge of the screen in the next window.

Finally, complete one test point at the centre of the screen:

You will then be returned to the output menu. If problems occur, repeat the calibration.

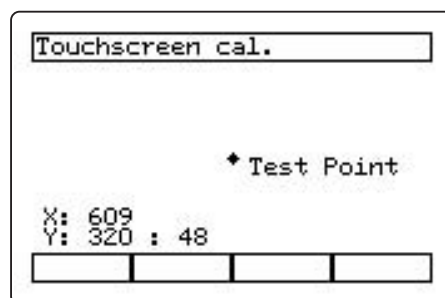
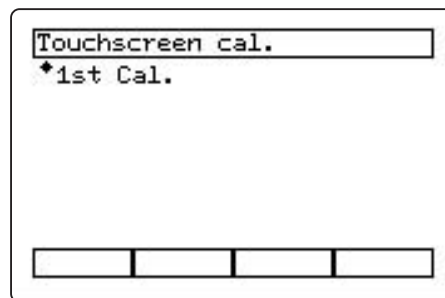
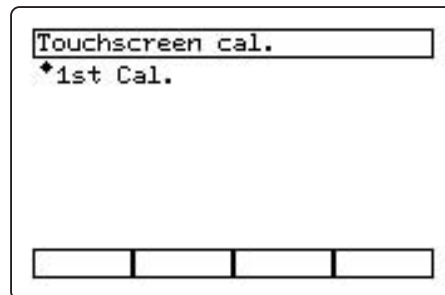
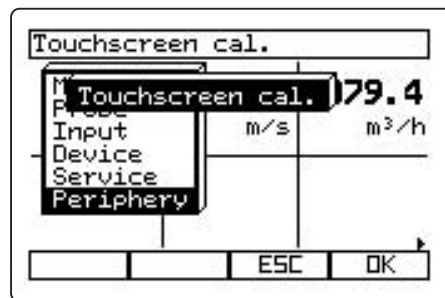

1. Description of the system components

1.1 Control unit 1.1.6 System settings

1.1.6.7 Password protection

A password can be set up for the control unit using testo software ComSoft 350/454.

Once a password is set up, the menu selection and the function buttons are blocked. It is still possible to take measurements.

The correct password must be entered in order to release menu selection and the function buttons.

Deactivate password protection

Change the password in your software such that the box for entering the password is empty i.e. do not enter any characters. The password protection is then deactivated.

1. Description of the system components

1.1 Control unit 1.1.7 Printing

1.1.7.1 Initial operation of printer

- Switch on the device.
- Assign the line feed to the function key **LF Pr**.
- Open the printer cover.
- Insert paper.
- Draw in the paper by pressing **LF Pr**, place the paper roll in the cover, close the cover.

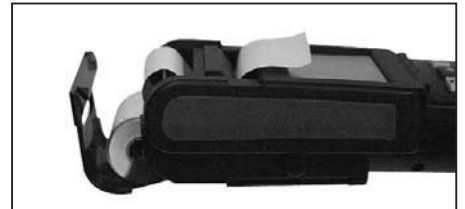

1.1.7.2 Printing readings

- Assign printing to the function key **Print**.
- Start the print-out by pressing **Print**.

The readings are printed line by line.

Printing the reading display

```
-----  
Control-Unit  
Testo t350/t454 CU  
SN: -0000001 /D  
-----  
Zeile 1  
Zeile 2  
Zeile 3  
-----  
Hall 2  
30.05.01 17:15:47  
  
1: -3.1 hPa  
2: 45.2 %  
3: 30.0 °C  
4: 16.8 td°C  
-----  
Fusszeile
```

1.1.7.3 Printing saved readings

- Select the desired location.
- **☰** -> **Memory** -> **Read out**.
- Select measurement protocol.
- Press function key **Print**.

The readings are printed column by column.

Printing saved readings







```
-----  
Control-Unit  
Testo t350/t454 CU  
SN: -0000001 /D  
-----  
Zeile 1  
Zeile 2  
Zeile 3  
-----  
Hall 2  
-----  
30.05.01 17:46:25  
-----  
Anzahl: 0001  
-----  
01 02 03  
hPa % °C  
-2.4 46.2 30.1  
-----  
04  
td°C  
17.3  
30.05.01 17:46:33  
-----  
Fusszeile
```

1.1.7.4 Printer settings

 -> **Device** -> **Printer**.

Select the menu item **Printer** with  or  and press . A pull-down menu appears with the entries **Contrast** and **Print text**.



Setting the contrast

Select the menu item "Contrast" with  or  and press . A slide bar appears which indicates the adjusted printer contrast. The contrast is lowest at the left and highest at the right. Increase contrast by pressing , decrease contrast with . If the lowest contrast is reached, the display automatically wraps to the highest contrast when  is pressed, and the converse. A text is printed when function key **Test** is pressed (as a check).

Setting the printed text

To document the assigned company and the assigned employee, it is possible to enter printed texts. Three lines and one footnote can be filled variably with numbers and letters.

 -> **Device** -> **Printer** -> **Print text**.

Select the menu item **Print text** with  or  and press .

Selection: **Line 1** **Line 2** **Line 3** **Footer**. The input dialogue appears when  is pressed.

Setting the printed text

```
-----  
Control-Unit  
Testo t350/t454 CU  
SN: -0000001 /D  
-----  
Zeile 1  
Zeile 2  
Zeile 3  
-----  
Hall 2  
30.05.01 17:15:47  
  
1: -3.1 hPa  
2: 45.2 %  
3: 30.0 °C  
4: 16.8 td°C  
-----  
Fusszeile
```

1. Description of the system components

1.1 Control unit

1.1.8 Differential pressure measurement

The control unit is equipped with integrated differential pressure measurement, e.g. for filter measurements or velocity measurements.

1.1.8.1 Setting the measuring range

2 measuring ranges are available, which can be selected with function keys.

- Measuring range 0...40 hPa, resolution 0.01 hPa: function key
- Measuring range 0...200 hPa, resolution 0,1 hPa: function key

When the control unit is switched on or before a measurement, the sensor is zeroed for approx. 4 seconds when or is pressed. The time until zeroing is completed is indicated on the display.

1.1.8.2 Differential pressure measurement

For the measurement, attach the connecting hoses to the inputs of the integrated differential pressure probe.

The differential pressure is indicated in the reading display.

We recommend zeroing at intervals with the hoses disconnected for longer measurements.

1.1.8.3 Showing/Hiding the integrated differential pressure sensor

-> ->

Select the menu item and press .

Select or via or and confirm with .

Zeroing phase

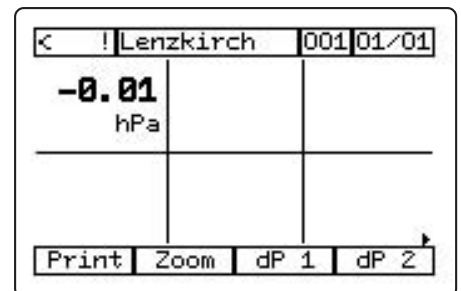
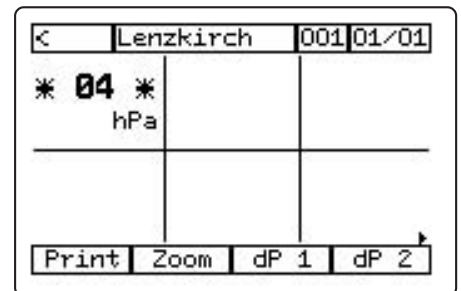

1. Description of the system components

1.1 Control unit 1.1.9 Factory settings

1.1.9.1 Resetting factory settings

Select menu item **Service**. The message **Reset Factory** is displayed.

When the **OK** key is pressed, the factory settings listed below are saved and the device is restarted.

You can return to the service menu with **ESC**.

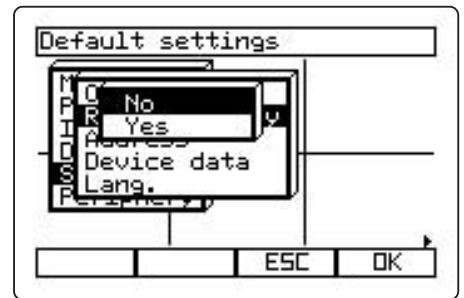

Accepting the factory settings

The following values are reset in the unit:

AutoOff	off
Pilot tube factor	1
Temperature	20 °C
Humidity	50 %RH
Pressure	1013 hPa
Density	1.292.2 g/m ³
Temperature unit	°C
Pressure unit	hPa
Velocity unit	m/s
Flow volume unit	m ³ /h
Calculated humidity values activated	none
VAC measurement regulations	none
Volume flow measurement	deactivated
Area	1 x 1 m ²
Offset factor	1
Measuring programs	none
Surface allowance	0 %
Damping	none
User-defined units	none
Scaling	none
T95 measurement regulations	none
Keypad lock (password)	none
Function keys	standard settings
Output to printer and memory	all menu entries activated

1. Description of the system components

1.1 Control unit

1.1.10 Location management

Location bar

In the reading display, press **OK** and then **◀**.
The currently existing locations are displayed.

When function key **Change** is pressed, the selection **New file**, **New loc**, **copy**, **Change**, **Delete**, **Print location** is displayed.

New file

A file can contain several locations. In the selection, move to **New file** and label these in the input dialogue.

New location

A new location is created by selecting **New loc**. The name is entered in the input dialogue.

Copying locations

Select a location as the source with **▲** or **▼** and press function key **Change**.

The selected location is loaded into the text editor, where it can be modified. After exiting the input dialogue, the modified or supplemented location appears at the end of the location list, i.e. a new location is created on the basis of the location used as the source.

Changing a location

Select the location to be edited in the location list with **▲** or **▼** and press function key **Change**.

Press **Change** again.

The selected location is loaded into the input dialogue, where it can be modified. After exiting the input dialogue, the modified location appears at the same place in the location list.

Deleting a file/location

Select the location to be deleted with **▲** or **▼** and select menu item **Delete**. The selected location and all protocols saved with it are deleted.

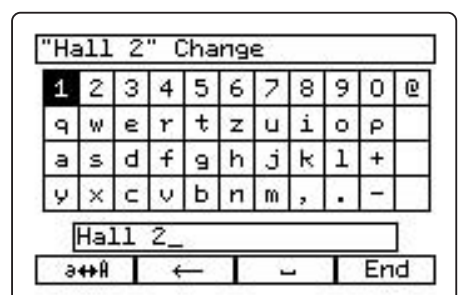
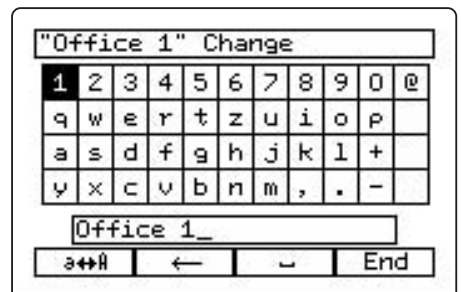
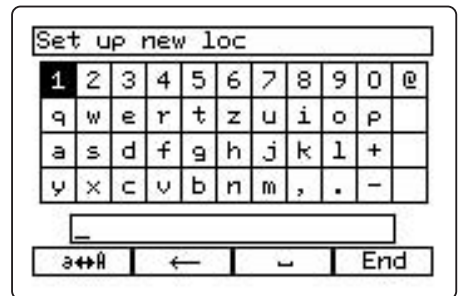
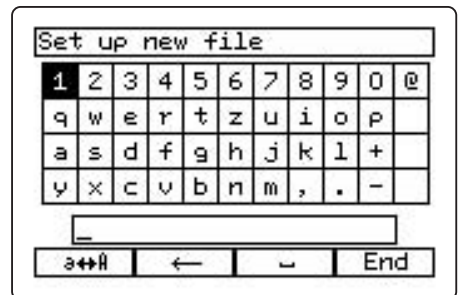
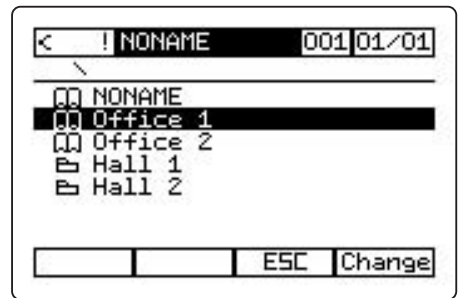

1. Description of the system components

1.1 Control unit 1.1.11 Printing locations

Printing all protocols of a location

- In the reading display, press **OK** and then **◀**.
- The location list is now on the screen.
Select the desired location with **▲** or **▼**.
- Press function key **Change**.
- Select menu entry **Print location** with **▲** or **▼**.
- All protocols of the selected location are printed with **OK**.

1. Description of the system components

1.1 Control unit 1.1.12 Measuring functions

1.1.12.1 Displaying minimum and maximum values

- Assign function key **Min** or **Max**.
- Pressing function key **Min** or **Max** displays the lowest or highest reading since the control unit was switched on.
- The function key is now highlighted in black.
- Pressing function key **Min** or **Max** again returns to the reading display.

1.1.12.2 Holding the current readings

- Assign function key **Hold**.
- Pressing function key **Hold** holds the current readings on the display. The function key is highlighted in black.
- Pressing function key **Hold** again returns to the reading display.

1. Description of the system components

1.1 Control unit 1.1.12 Measuring functions

1.1.12.3 Calculating the mean

To calculate a mean, assign a function key with **Mean** and press this function key.

Calculating the time mean

Select the function key **Timed** with **▲** or **▼** and confirm with **OK**. In order to calculate the mean, the measurement period in which the mean is to be calculated must be entered in the input dialogue.

The function keys in the reading display are then assigned as follows:

- Start** starts the timed mean calculation over the entered measurement period. The \bar{x} symbol in the system bar indicates the proceeding timed mean calculation.
- ESC** terminates the timed mean calculation.
- End** terminates the timed mean calculation in time before the defined measurement period has expired. The result is displayed. After the expiry of the measurement period, the timed mean is indicated automatically on the display.
- ESC** returns to the reading display.

Printing a timed mean

- Select the location for which the timed mean was saved.
- Press menu key **☰**.
- Select **Memory**.
- Select **Read out**.
- Select the protocol by the date and time from the list and confirm with **OK**.
- Print the protocol with function key **Print**.

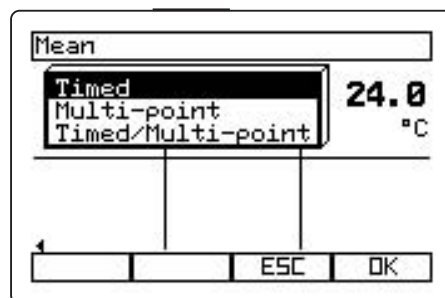

Beginning mean calculations

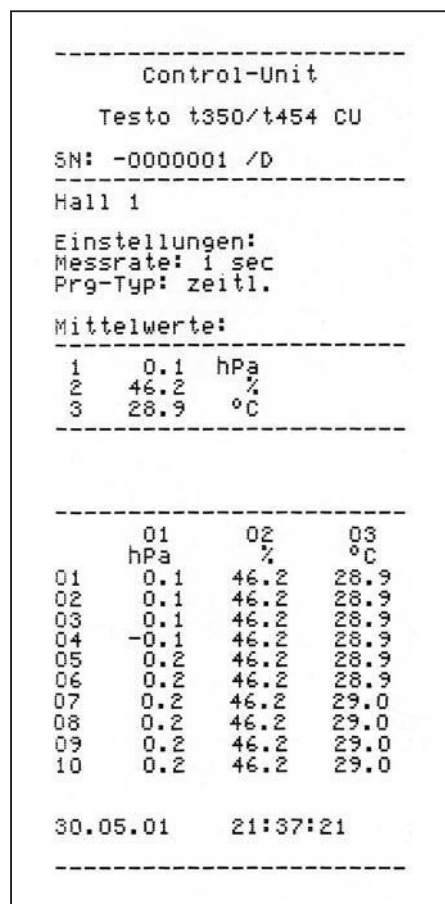
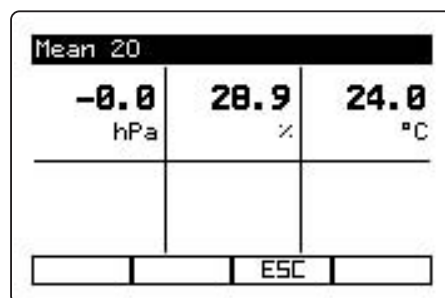
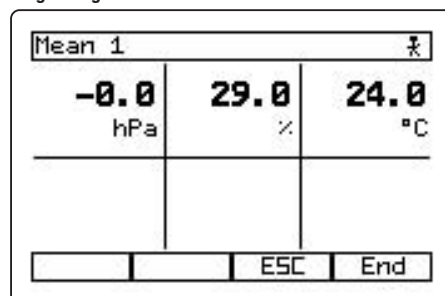

1. Description of the system components

1.1 Control unit 1.1.12 Measuring functions

Mean calculation by points

The mean calculation by points generates the arithmetic mean of each individual measuring channel. The values relevant for the mean calculation are recorded manually by pressing **Start** function key.

The number of readings recorded per measurement channel is displayed in the system bar. For example, the display **Mean 5** means that five readings have been saved per measurement channel.

Select the function key **Multi-point** with **▲** or **▼** and confirm with **OK**.

The function keys in the reading display are then assigned as follows:

Start saves the current readings for the mean calculation.

ESC terminates the mean calculation by points.

End adds the readings and divides the sum by the number of readings. The timed mean appears on the display.

ESC returns to the reading display.

Printing a mean calculation by points

- Select the location for which the mean calculation by points was saved.
- Press menu key **☰**.
- Select **Memory**.
- Select **Read out**.
- Select the protocol by the date and time from the list and confirm with **OK**.
- Print the protocol with function key **Print**.

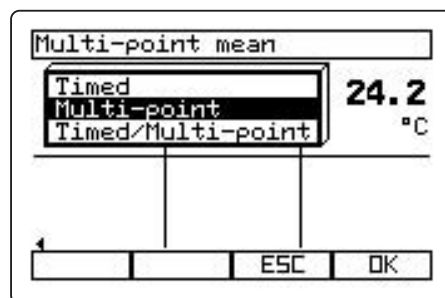

Beginning mean calculations

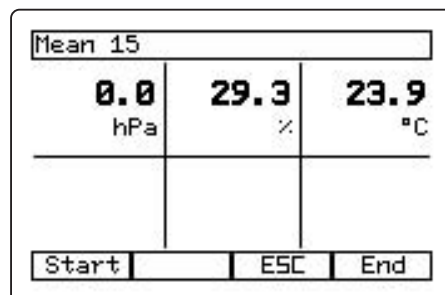
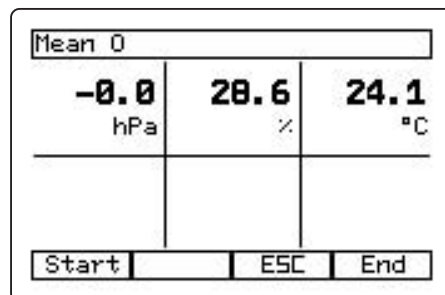

1. Description of the system components

1.1 Control unit 1.1.12 Measuring functions

Mean calculation by time/by points

The multi-point mean calculation generates the arithmetic mean of each individual measuring channel. The values relevant for the mean calculation are recorded manually by pressing function key **Start**. In contrast to the multi-point mean calculation, a mean calculation in time per measuring channel is conducted instead of the current readings when the start key has been pressed. This mean value in time is then saved and used for the time/multi-point mean calculation.

The period in which measurements are recorded per measurement channel is displayed in the system bar. For example, display **Mean 16** means that four readings taken in time have been saved over a period of four seconds.

Select the function key **Timed/Multi-point** with **▲** or **▼** and confirm with **OK**.

The function keys in the reading display are then assigned as follows:

- Start** saves the current readings for the mean calculation.
- ESC** terminates the mean calculation by points.
- End** adds the readings and divides the sum by the number of readings. The time/point mean value appears on the display.
- ESC** returns to the reading display.

Printing a mean time/point calculation

- Select the location for which the time/point mean calculation was saved.
- Press menu key **☰**.
- Select **Memory**.
- Select **Read out**.
- Select the protocol by the date and time from the list and confirm with **OK**.
- Print the protocol with function key **Print**.

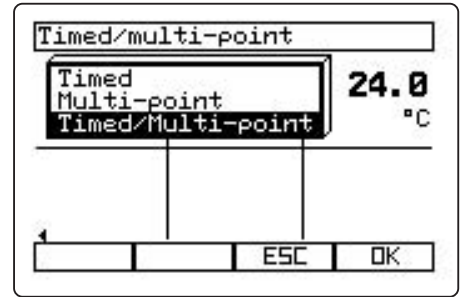

Beginning mean calculations

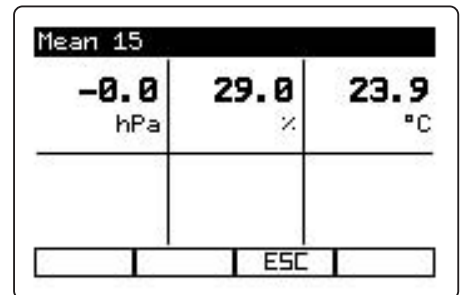
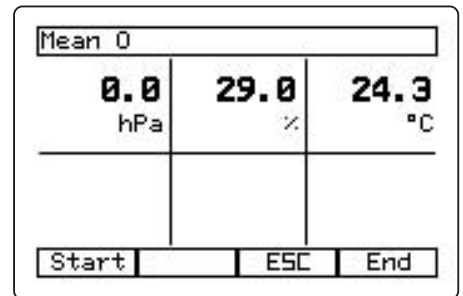

1.2 Logger

- 1.2.1 General description
- 1.2.2 Inserting batteries
- 1.2.3 Connecting the rechargeable battery pack
- 1.2.4 Probes
- 1.2.5 Menu guide with connected logger
- 1.2.6 Function key assignment with connected logger
- 1.2.7 Measuring
- 1.2.8 Printing
- 1.2.9 Data management

1. Description of the system components

1.2 Logger 1.2.1 General description

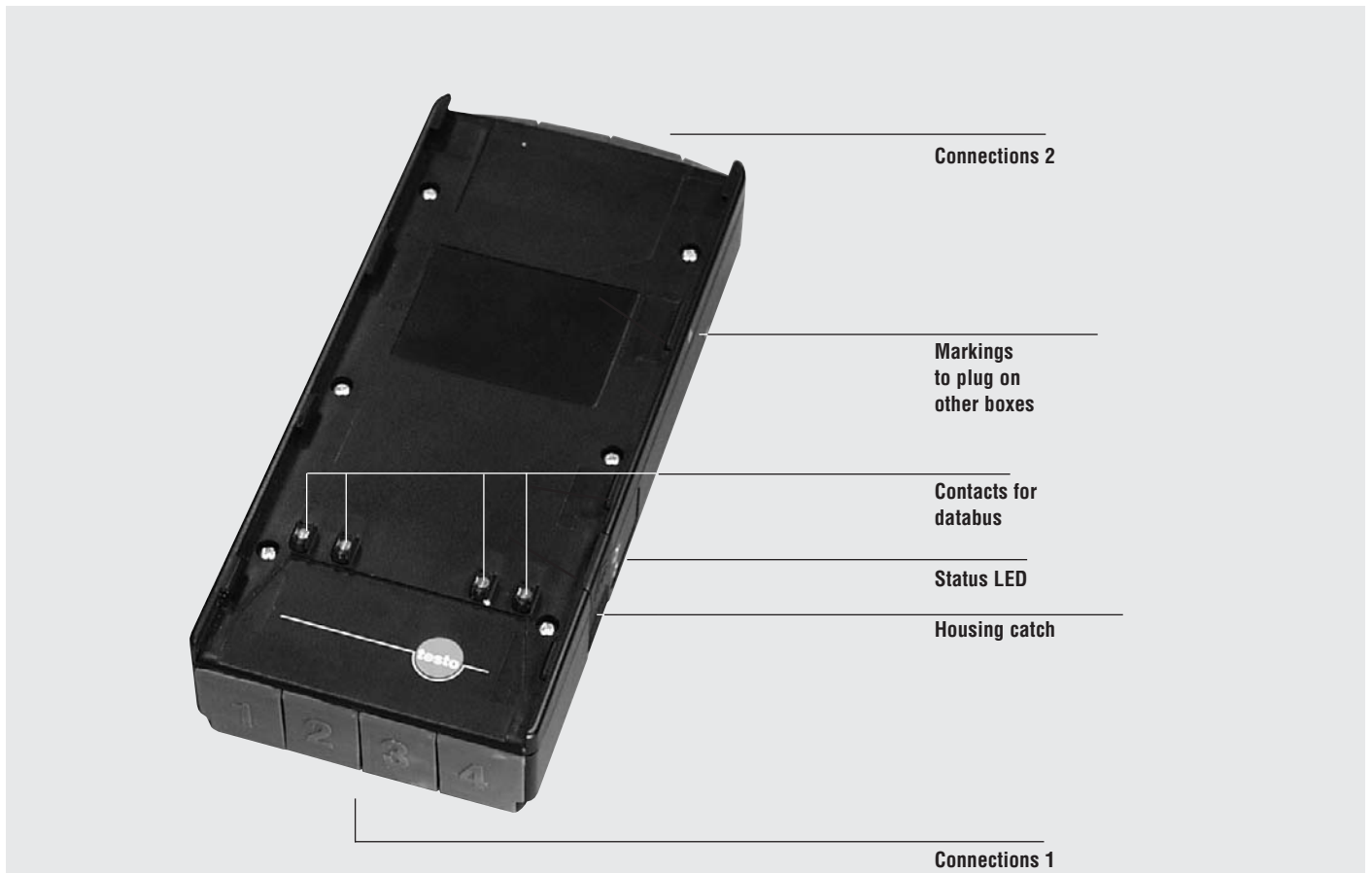

Connections 2: Testo databus / supply

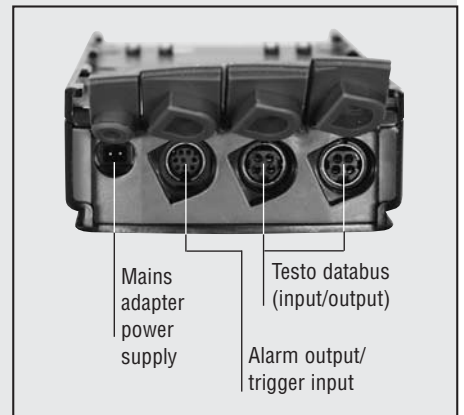

Connections 1: Probe

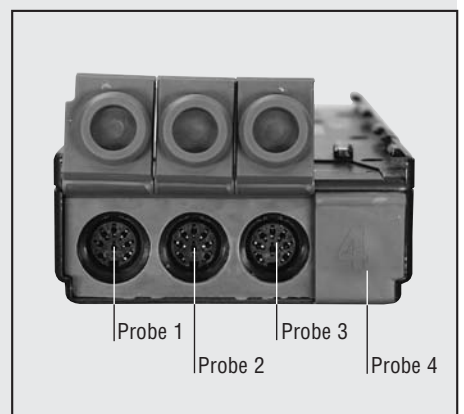

Depending on the application, up to 8 analyser boxes equipped with different probes and up to 20 loggers can be interconnected through the Testo databus. The logger measures and stores the values even when not connected to the Control Unit.

Probe connections

The logger is equipped with four probe sockets. The following probes can be operated with the logger:

Temperature probes, flow velocity probes, pressure probes, humidity probes, CO, CO₂ probes, current and voltage cables, rpm probes.

Probe detection

The logger detects the probe connected to the probe sockets every time the device is started. Starting is conducted by switching on the Control Unit, the powerbox or by initialising with PC/laptop.

Power supply

The power supply can be implemented from 4 different sources: with rechargeable batteries, batteries, mains adapter or through the connected Testo databus supply.

Testo databus connection

Four contacts each are located on the top and bottom of the housing to provide direct contacts to other plugged-on components. Alternatively, the bus connection can be made by cables. The bus connection must not be disconnected under load conditions.

1. Description of the system components

1.2 Logger

1.2.2 Inserting batteries

The logger is supplied by 4 rechargeable cells of type Sanyo HR-AAU 1400 mAh, the same as the Control Unit battery).

It is also possible to use 4 common rechargeable batteries or batteries to supply the logger. These are connected to the circuit board by spring contacts. Common rechargeable batteries/batteries cannot be charged.

1.2.3 Connecting the rechargeable battery pack

The rechargeable battery pack is connected to the instrument by a cable and a socket. When inserting the rechargeable batteries, avoid kinking or damaging the connecting cable. When the rechargeable batteries are inserted, the label on the rechargeable batteries must be visible from above.

1.2.4 Probes

Any type of probe may be connected to any of the probe sockets of the logger.

Rechargeable battery pack



Battery pack connection



Connectable probes

The following probes can be connected to the probe sockets of the logger (8-pole socket):

All thermocouple temperature probes (types K, J, S, including with EEPROM)

Temperature probe (NTC)

Pressure probes

Vane probes

Humidity probes with integrated calibration keys

Humidity probes without integrated calibration keys

Thermal probes

CO₂ probe

CO probe

Gas leak detection probe

Combi probe for %RH, °C, m/s

Shell anemometer

Pt 100 probe

U / I probe

rpm probe

1. Description of the system components

1.2 Logger

1.2.5 Menu guide with connected logger

Depending on the instrument configuration, your menu may differ from the menu described below.

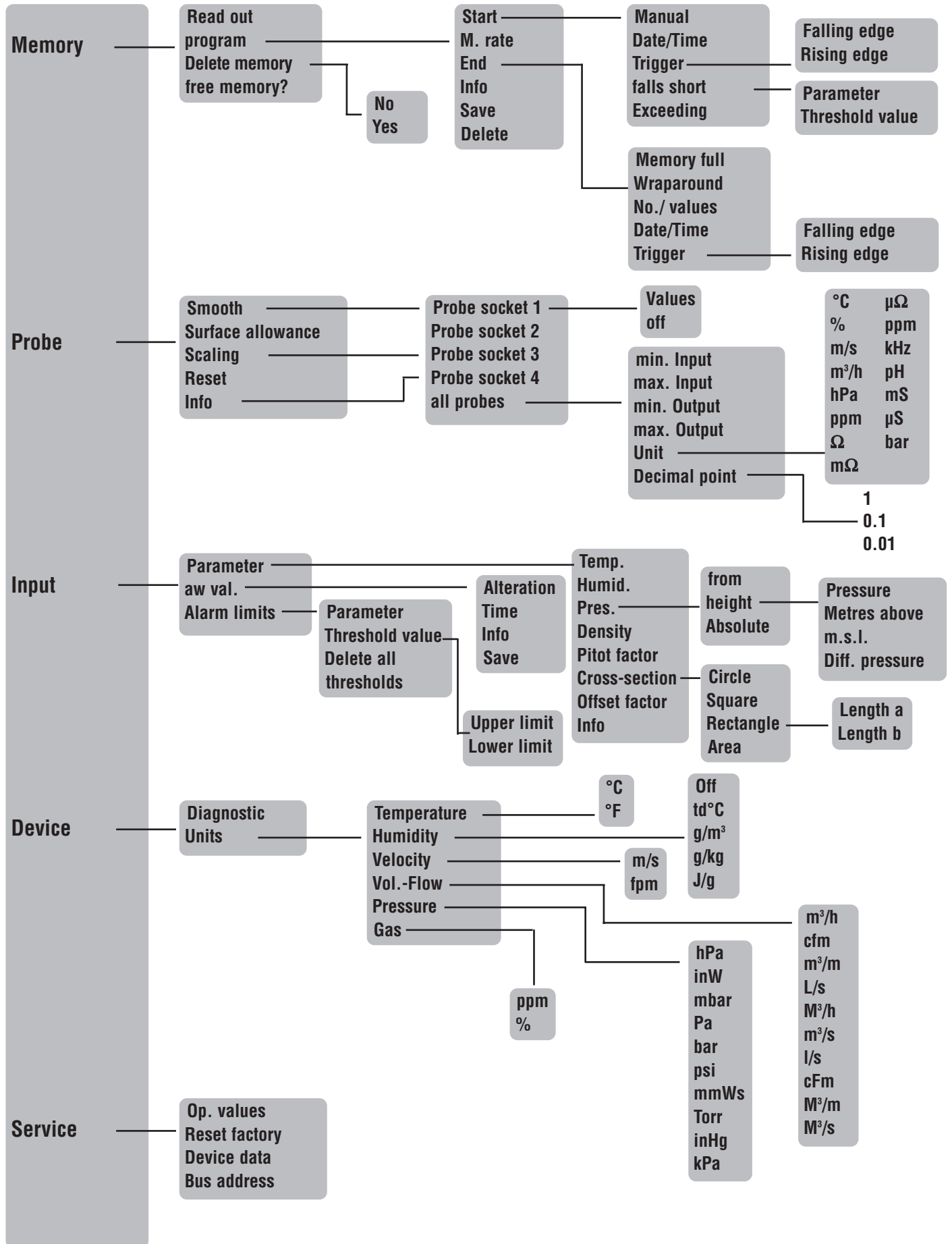

1. Description of the system components



1.2 Logger

1.2.6 Function key assignment with connected logger

The function buttons should be assigned as follows via the control unit / control unit with attached logger:

Function key assignment	
Free, unassigned function key	<input type="text"/>
Zoom measured values	<input type="button" value="Zoom"/>
Hold current measured value	<input type="button" value="Hold"/>
Display max. values since switching on	<input type="button" value="Max"/>
Display min. values since switching on	<input type="button" value="Min"/>
Mean calculation	<input type="button" value="Mean"/>
Activate volume flow rate measurement (with flow or external differential pressure probe)	<input type="button" value="Vol"/>
Activate/deactivate flow velocity (with an external differential pressure probe)	<input type="button" value="m/s"/>
Switch off alarm	<input type="button" value="Aloff"/>
With at least one turbulence probe: Turbulence calculation with connected probe	<input type="button" value="Turb"/>
Zero pressure probe connected to probe socket (with connected differential pressure probe)	<input type="button" value="PExt=0"/>
Zero the CO probe	<input type="button" value="ppm=0"/>
Start/stop measuring program	<input type="button" value="Start"/> <input type="button" value="Stop"/>
Determine system configuration	<input type="button" value="Search"/>
Save the measured values	<input type="button" value="Memory"/>
Print the measured values	<input type="button" value="Print"/>
Printer line feed	<input type="button" value="LF Pr"/>
Differential temperature	<input type="button" value="Delta T"/>

To reverse assignment

Press menu button  , release menu button  and then press immediately the defined function button.

Confirm empty field in selection via  . Assignment has been reversed. Function button is free.

The logger is equipped with internal memory. Apart from the program code, additional calibration data is stored in the program memory. Measurement records, their values and configuration data is stored in the data memory.

The data memory of the logger can record a max. of 250,000 measured values. The user can execute various actions (saving individual values or measuring programs) with the Control Unit (without PC) or the PC plug-in card, which cause the measured values to be recorded or stored. The different memory functions are programmed using the Control Unit and are activated by the function keys "Start" or "Save". Values are stored automatically for mean calculation.

Measurement records are assigned explicitly to the location defined on the Control Unit. The location list is managed using the Control Unit; the logger recognises only its assigned location. The location active at the time of the memory operation is stored in the associated measurement record.

Caution!

When a measuring program is running, changing the location takes effect only for the next stored record.

Apart from the measured value channels, the time and date are also stored in each record. The time is stored separately for each memory cycle because measuring programs with asynchronous measuring cycles are possible (see use of the trigger input or data reduction).

The logger is able to process measuring programs independently. The required parameters are programmed on the Control Unit or using the PC software. Only one measuring program can be loaded and activated for each logger.

Starting a measuring program:

- Manual (by pressing the corresponding function key on the Control Unit, which issues a command to the logger to start the program)
- Date/time (the program is started at a particular date/time)
- Shortfall of a measured value on a particular channel
- Overshooting of a measured value on a particular channel
- Trigger (logger only, program start is dependent on the trigger input)

1. Description of the system components

1.2 Logger 1.2.7 Measuring

Terminating the measuring program

- Memory full (data recording proceeds until the data memory is full)
- Wraparound memory (when the end of the data memory is reached, the values at the beginning are overwritten)
- Number of values (an adjustable number of measured values is recorded)
- Date/time (the program terminates at a particular date/time)

testo 454 only: trigger.

Program termination is dependent on the trigger input.

Trigger input for measuring program start/stop

The trigger input can be used as a criterion to either start or stop measuring programs.

The trigger input of the logger can be activated via the mini-DIN socket and reacts to a positive or negative signal edge of 8 V. Galvanically isolated activation with optical switches is advisable.

The following parameters can be adjusted for the trigger input:

- The measuring program is started when a positive edge is detected in the trigger signal. The program is also stopped by a positive edge.
- The measuring program is started when a negative edge is detected in the trigger signal. The program is also stopped by a negative edge.
- With level-dependent trigger signals, the data recording proceeds at the adjusted measuring rate as long as the trigger signal is active.

Alarm/trigger cable assignment:

- Trigger + red
- Trigger - clear/grey
- Alarm 1 yellow
- Alarm 2 green

Measuring cycles/measuring rate

- shortest measuring rate = 1 sec,

depending on the connected probes

Caution!

A measuring rate of 1 sec. cannot be achieved with all combinations of probes.

- longest measuring rate = 24 h

Software update

A software update of the firmware for the Control Unit, the logger and the flue gas analyser unit is possible via the serial interface.

Ask your Testo service partner for more information.

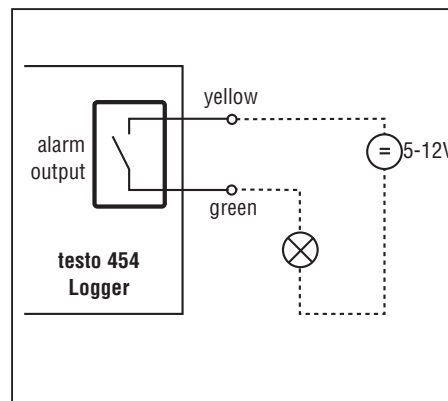

1.2.8 Printing

Ensure that the logger from which you wish to print data is selected on the display of the Control Unit. Assign a function key with **Print**. When this key is pressed, all channels of the logger are printed with the current measured value, date/time and the selected location.

1.2.9 Data management

The logger is equipped with a data memory. Measurement records, their values and configuration data are stored in the data memory.

With a full equipping of probes (four probes with three parameters each), the maximum number of measuring cycles with continuous storing is 20,000 (one measurement record at one location).

With one connected probe (one measurement channel), the maximum number of measuring cycles with continuous storing is 240,000 (1 measurement record at one location).

The data stored in the memory are assigned to the location identifier in the top line of the display. This name can be edited by pressing **OK** and **◀**. Several names can be stored in a hierarchical folder structure.

Input with a barcode pen

The barcode pen can be used as an input device. This is connected to the RS-232 interface. If no memory program is active, a correctly scanned location identifier is immediately activated. Otherwise, this occurs when the measuring program has been executed.

1.3 Analyser box 350 M/XL

- 1.3.1 General description
- 1.3.2 Testo databus
- 1.3.3 Menu guide with connected analyser box
- 1.3.4 Function key assignment with connected analyser box
- 1.3.5 Menu "Display sequence"

1. Description of the system components

1.3 Analyser box 350 M/XL

1.3.1 General description

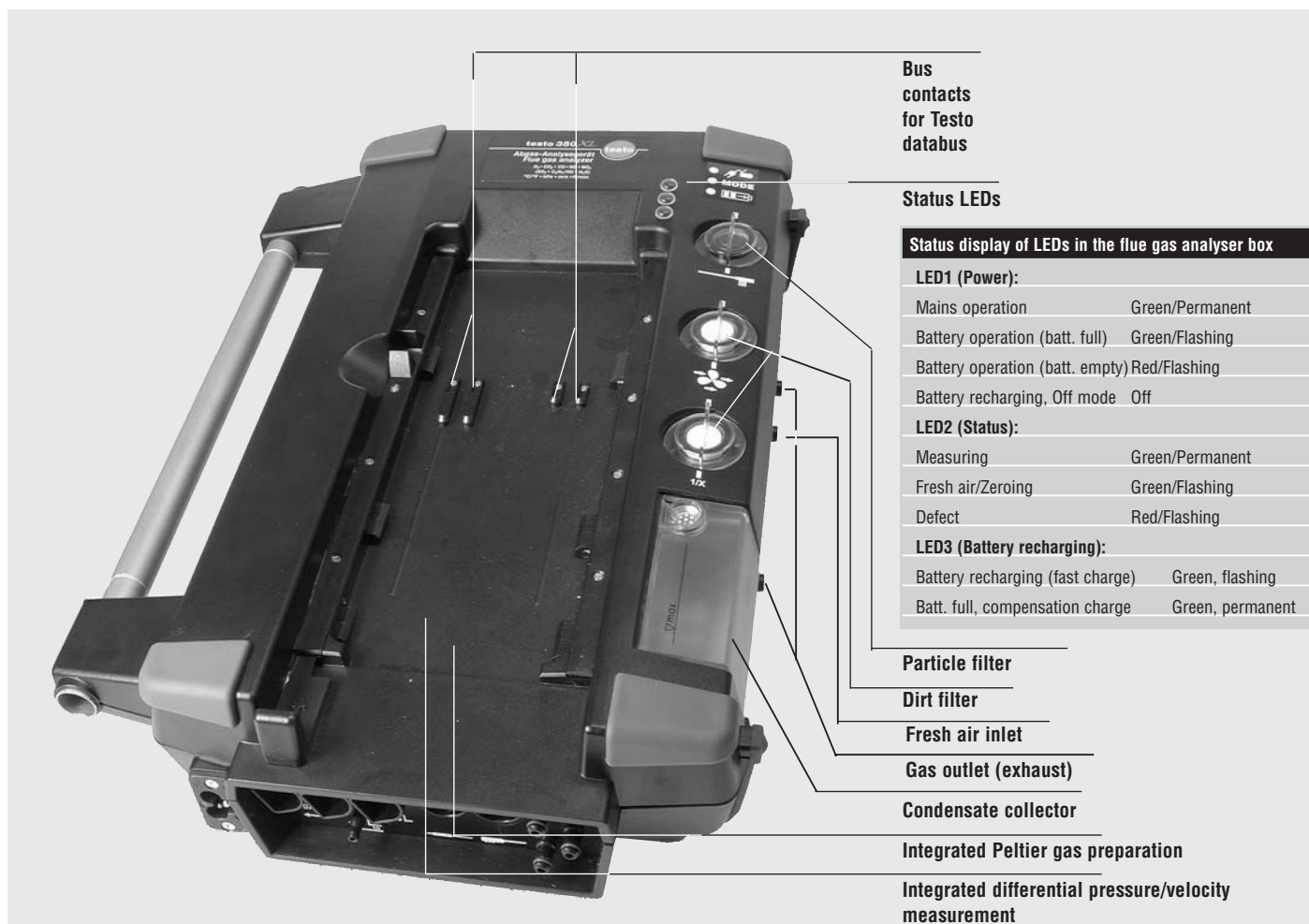

The analyser box contains the gas sensors, the measured gas and purging pumps, Peltier gas preparation, gas paths, all filters, electronic evaluating and storage, the mains adapter and NiMH battery (service time approx. 2 - 3 hours of continuous operation, reduction with CO2 IR module).

Connections

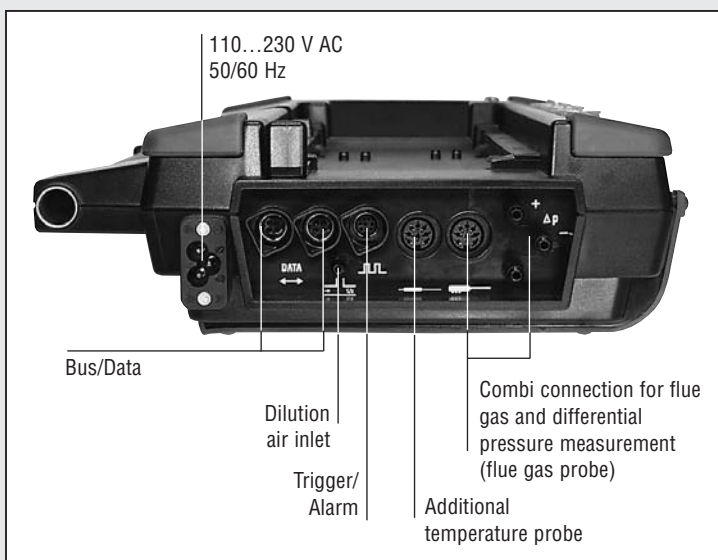

Differences between testo 350M and testo 350 XL:

Description	testo 350 M	testo 350 XL
Max. gas sensors	4	6
Basic version equipped with	O ₂ ; CO	O ₂ , CO, NO; NO ₂
Capable of extension with	NO; NOlow; NO ₂ ; SO ₂ ; COlow; CO ₂ (IR)	SO ₂ , H ₂ S; HC; NOlow; COlow; CO ₂ (IR)
Fresh air valve	Option	Standard
Trigger input	—	Option

1. Description of the system components

1.3 Analyser box 350 M/XL 1.3.1 General description

Functional description

The analyser unit is controlled and accessed either by the Control Unit or the testo plug-in card (PCMCIA card) with the COMFORT3 software.

The analyser unit is also able to process measuring programs independently after programming with the Control Unit or the testo PCMCIA card. Only one measuring program can be loaded and activated in each analyser unit.

The flue gas is drawn over the flue gas probe in the gas preparation when the measured gas pump is started manually or automatically. Here, the measuring gas is suddenly cooled to 4 - 8 °C. This precipitates the condensation with the lowest absorption of NO₂ and SO₂. The condensate is pumped at regular intervals by the hose pump at the bottom of the unit into the condensation tank.

The dry gas passes through a particle filter, which holds back the particles. The gas then passes through the pump to the gas sensors. A very small proportion then diffuses through membranes to the sensors, which issue a signal. The surplus measuring gas exits the unit through the exhaust pipe.

The CO sensor is equipped with CO shut-off and purging facilities. This shut-off facility can be activated manually or automatically at a programmable concentration (see "Switch-off" under "Flue gas spot measurement").

Dew point calculation

This is a calculation of the dew point by software (for the calculation, see "Measurement notes", "Flue gas calculations"). This displayed dew point is only correct when no processes which influence the humidity occur in the flue gas path (e.g. SO₂ scrubber or similar). For this, the temperature and the humidity or the dew point of the combustion (ambient) air must be entered in menu -> . These values can also be determined with the aid of the Control Unit and a humidity probe.

HC measurement (option for testo 350 XL)

This probe is a catalytic oxidation sensor which requires a certain amount of O₂ to operate (approx. 2 %). This probe would be destroyed at lower values. The probe therefore switches off at inadequate O₂ values. If it is known from the beginning that values below 2 % exist, the probe can also be switched off manually (main menu -> or via assigned function button). starts the measuring box with a zeroing phase (1min).

Note

In order to ensure proper functioning, the pellistor is heated to approx. 500°C, for approx. 10min. This means that 10min after the instrument is switched on, the sensor has to be zeroed again to avoid drift (in the "Minus" range).

Zeroing function is deactivated and reactivated via function button or instrument.

1. Description of the system components

1.3 Analyser box 350 M/350 XL 1.3.1 General description

Measuring range extension option (measured gas dilution)

To extend the measuring range, the measured gas for the CO sensor only is diluted with ambient air or nitrogen in a controlled manner. For this purpose, the diluting gas is drawn through a separate gas inlet by a pump and a valve operating on the principle of pulse width modulation. A filter is installed to protect the gas path against dust. The dilution factors can be set manually in menu **Input** -> **Dilution** (or via assigned function button **1 x**). It is also possible to calibrate the unit with test gas when dilution is switched on to eliminate any measuring errors caused by dilution. An active dilution stage is indicated in the measuring menu in the upper bar at the top left (x2). The clicking sound of the valve is also clearly audible.

Notes:

- If the ambient air contains interfering gases, push the hose onto the dilution inlet and place in a clean atmosphere
- If gas from a gas cylinder is used, observe a max. pressure of 30 hPa.
- Diluting also changes the resolution of the reading display (e.g. undiluted resolution 1 ppm, with factor 10: resolution 10 ppm)

Possible dilution factors:

Factor	Ratio of diluting gas : measured gas
1	no dilution
2	1 : 1
5	4 : 1
10	9 : 1
20	19 : 1
40	39 : 1

Schematic diagram:

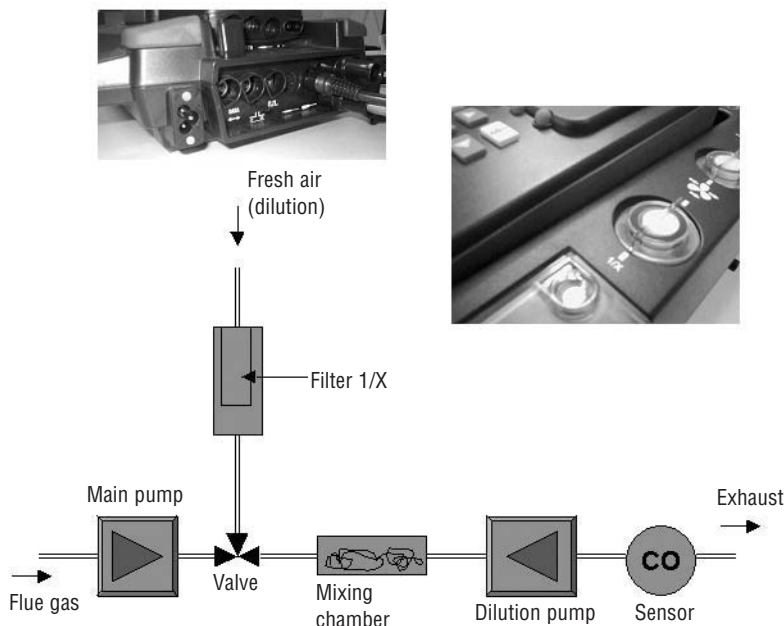

1. Description of the system components

1.3 Analyser box 350 M/350 XL 1.3.1 General description

Functionality:

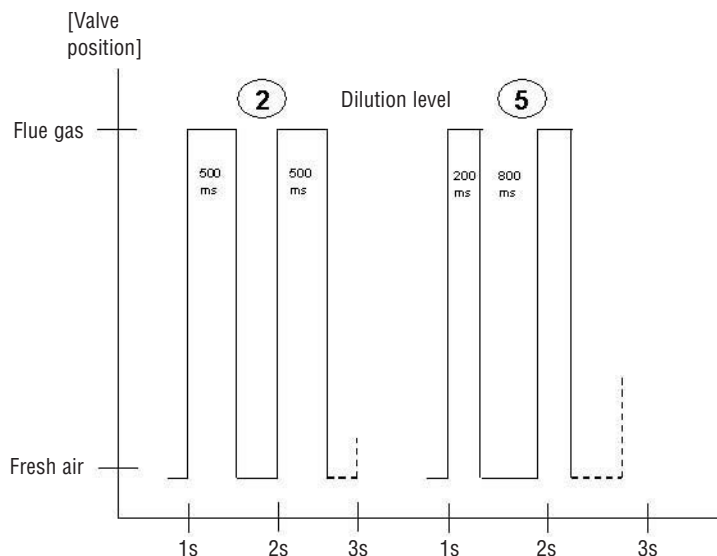

Display of values:



Actual CO value in flue gas
Dilution level is switched via function button if required

Technical data:

Level	Measuring ranges with CO (Standard)	Resolution	Measuring ranges with COlow	Resolution
1	0 to 10,000ppm	1ppm	0 to 500ppm	0.1ppm
2	0 to 20,000ppm	2ppm	0 to 1,000ppm	0.2ppm
5	0 to 50,000ppm	5ppm	0 to 2,500ppm	0.5ppm
10	0 to 100,000ppm	10ppm	0 to 5,000ppm	1ppm
20	0 to 200,000ppm	20ppm	0 to 10,000ppm	2ppm
40	0 to 400,000ppm (=40%)	40ppm	0 to 20,000ppm	4ppm

Accuracy plus <2%, e.g. <5% of reading + <2% = <7% of reading

To eliminate influence: adjustment with dilution level connected

Recommendation for dilution levels:

Level	CO concentration in flue gas	
	COlow	CO standard
1	0 to 100	0 to 500
2	50 to 500	300 to 2,000
5	250 to 1,500	500 to 10,000
10	400 to 3,000	1,500 to 20,000
20	1,000 to 6,000	3,000 to 80,000
40	2,000 to 20,000	6,000 to 400,000

Examples of typical applications:

- Measurements in reduced burner atmosphere
- Adjustment of industrial burners (from high to low CO ...)
- Optimisation and tuning of gas turbines
- Motor measurement at high H₂ levels (controlled motors)
- Extension of measuring times during long-term measurements (low load of CO measuring cell)

1. Description of the system components

1.3 Analyser box 350 M/350 XL 1.3.1 General description

Differential pressure measurement

Differential pressure measurement is integrated in the analyser box. Velocity measurement can be carried out simultaneously with gas analysis using this function and Pitot tubes. The instrument can also calculate mass flows if required.

Probe sockets

The analyser box has 2 temperature probe sockets, one for flue gas temperature and one for ambient temperature, for example. Temperature probes of type K (NiCrNi) and NTC can be connected to the probe sockets.

Note

A probe must be plugged into the socket in order to display the volume flow or mass flow  .

Fresh air rinse

Schematic diagram with fresh air valve:

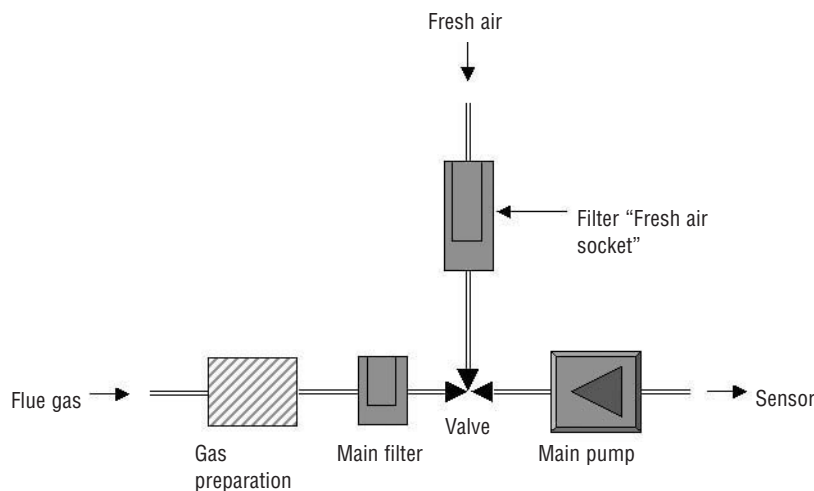

Schematic diagram without fresh air valve (**tests 350M** only):

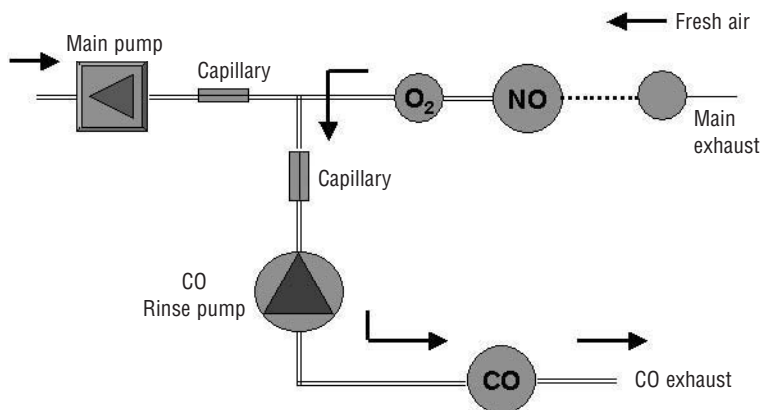

Advantages of fresh air rinse:

- Drift is avoided
- Memory effect is eliminated
- "Rest" for measuring cell (measurement accuracy is adhered to)
- Service life of measuring cell is extended

1. Description of the system components

1.3 Analyser box 350 M/350 XL 1.3.1 General description

Option: CO₂ IR module

An infrared (IR) sensor module is used for direct measurement of CO₂ concentration. This module consists of a sensor and a fixed additional board. An absolute pressure sensor, which eliminates any influences from fluctuations in absolute pressure on the CO₂ sensor, is located on this board. An absorption filter (CO₂ filter) is also enclosed for zero point adjustment.

Display parameter / possible units

The CO₂ parameter appears in the selection list in the **Display** menu of the built-in CO₂ IR module. The calculated CO₂ display can still be selected in order to be able to see the difference between “direct CO₂ measurement” and “calculated CO₂”.

MCO₂ (CO₂ mass flow) and Pabs (absolute pressure) can be selected as additional parameters.

If the instrument is equipped with a CO₂ IR module, the CO₂ mass flow is determined using this module and not via “calculated CO₂”.

The input menu to enter absolute pressure is blanked out in the built-in CO₂ IR sensor. The absolute pressure measured is used to calculate velocity and mass flow.

Note

At ambient temperatures of <10°C, the CO₂ infrared sensor requires a brief heating period to achieve full measurement accuracy. This is typically -5°C for 15 minutes.

Selectable units

CO₂i: %CO₂

MCO₂: kg/h, kg/T, t/h, t/T, t/J

Pabs: hPa, mbar

Checking the CO₂ module

The CO₂ module should be checked regularly using the absorption filter in order to ensure accurate readings.

Information on how to use the filter is included in the instructions which come with the CO₂ filter.

The displayed CO₂ value should be <0.3%CO₂. If the value is higher, a zero point adjustment and possibly a gradient adjustment should be carried out (see Chapter 4.1 Service and maintenance, flue gas analyser).

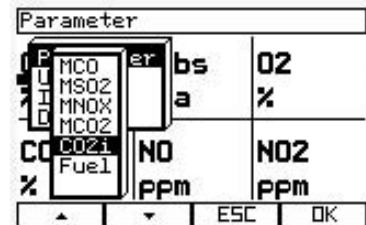

1. Description of the system components

1.3 Analyser box 350 M/350 XL

1.3.3 Menu guide with connected analyser box

Depending on the instrument configuration, your menu may differ from the menu described below.

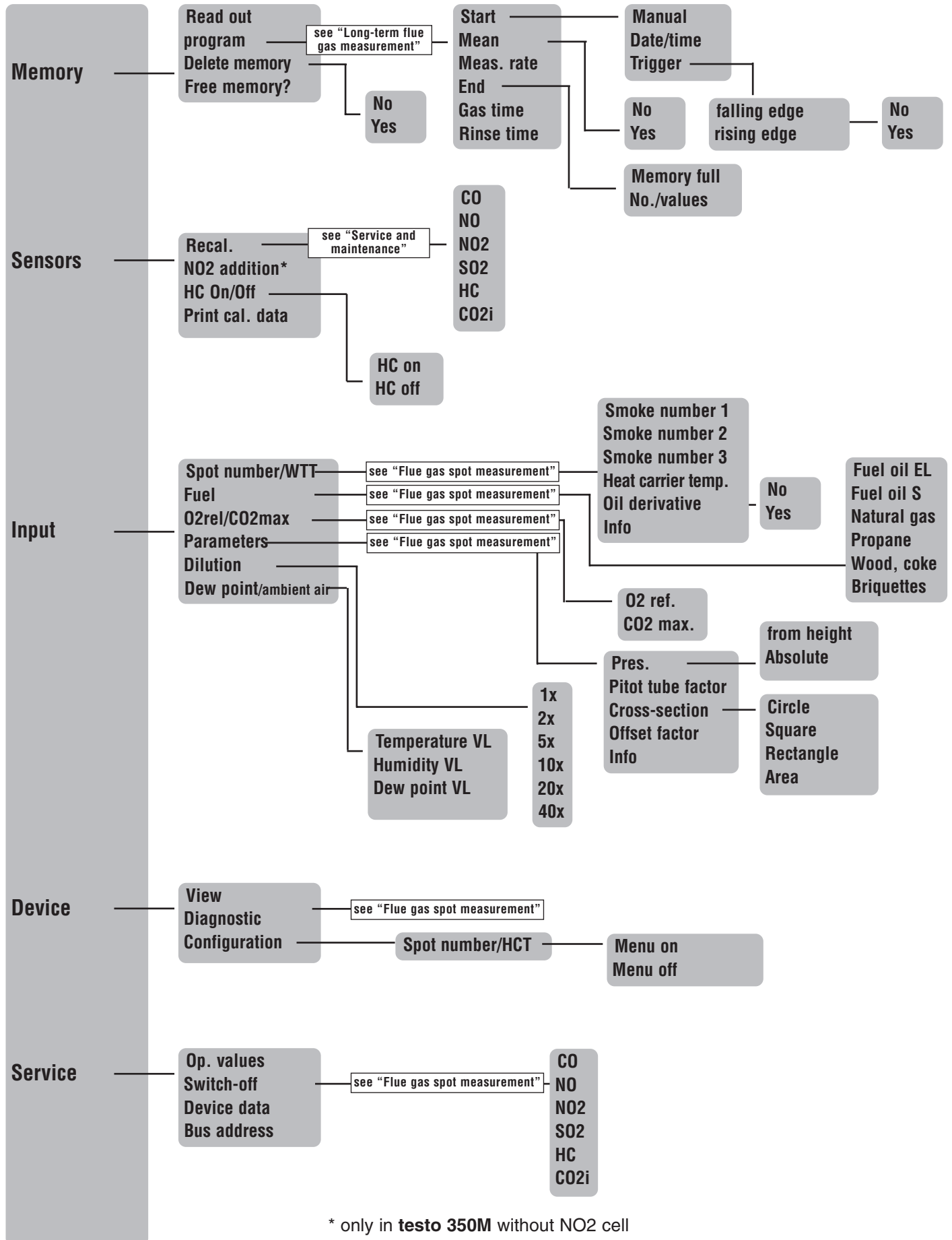



















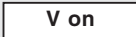





1. Description of the system components

1.3 Analyser unit 350 M/350 XL

1.3.4 Function key assignment with connected analyser box

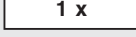
Free assignment by:

pressing , releasing  and then immediately pressing the function key.

Function key assignment	
Starts the measuring gas pump and indicates the readings on the display.	
When  is pressed, the function key changes to  . The measuring gas pump stops, the readings are frozen at  .	
Magnified display of the readings (3 readings on one display screen [magnified] or 6 readings [standard]).	
Switches on and zeros velocity rate measurement with pitot tube and pressure probe.	
Manual storing of the current values under the displayed location name.	
Use of the two temperature inputs of the analyser box as separate 2-channel temperature measurement with DT display.	
Activates the separate differential pressure measurement in the analyser box.	
 starts a previously programmed measuring program.	
Prints all displayed readings.	
Printer line feed.	
Initiates the purging and zeroing phase (1 minute). The device draws fresh air through the measurement gas inlet or the fresh air valve (if fitted).	
Manual change from measured gas to atmospheric air.	
Manual deactivation and purge with fresh air.	
Manual activation of a deactivated CO sensor in the gas path.	
Switching the dilution stage (digit in front of x corresponds to the setdilution factor)	
Switching the HC module on/off	 
Direct display of all error messages	

Opening the main menu

The main menu is opened with .

The desired submenu is selected with  or  and

this is accessed by pressing .

The menu can be closed with  or .

If an analyser box is selected and a measurement is currently in progress (pump running), the pump is stopped.

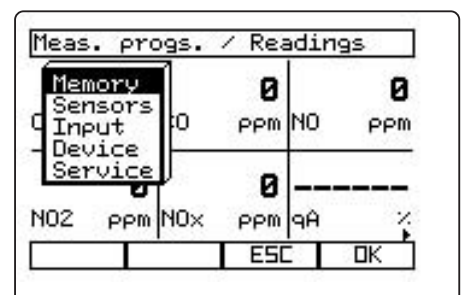

1. Description of the system components

1.3 Analyser box 350 M/350 XL 1.3.5 Menu 'Display sequence'

The following parameters can be set in menu Display sequence
(depending on the equipping):

<u>O₂ / CO / NO / CO_{low} / NO_{low} / SO₂ / NO₂ / HC / H₂ / CO_{2i}</u>	
Directly measured parameters	
NOx	Addition of NO and NO ₂
Only NO fitted	NO measured and entered NO ₂ factor
FT	Flue gas temperature
AT	Ambient air temperature
dT	Differential temperature
T1/T2	Temperature inputs, analyser box for differential temperature measurement
qA	Flue gas loss
CO ₂	CO ₂ display (calculated)
Lamb	Air surplus index λ
Eta	Efficiency η
uCO	Undiluted CO (CO in relation to 0 % O ₂)
SSN	Smoke spot number (input value)
OILD	Oil derivative (input)
HCT	Heat carrier temperature (input)
O _{2b}	O ₂ reference value (for mg/m ³)
CO _{2M}	CO ₂ max. value (depending on the selected fuel)
dP	Differential pressure measurement
Batt.	Voltage display of the analyser box rechargeable battery
DT	Instrument temperature
O/c	Operation hour counter
Pump	Pump performance display
Vel	Gas velocity (calculated by differential pressure measurement)
Vols	Volume velocity (calculated)
DP	Dew point (calculated)
MCO / MSO ₂ / MNOx / MH ₂ S	Mass flow display
Fuel	Fuel
Unused	

The following units can be selected:

For the analyser box	
For temperature	°C; °F
Gas parameters (without O ₂)	ppm, Vol. %, mg/m ³ , g/GJ, mg/KWh
Mass flow	kg // kg/T // t/h // + t/D // + t/Y = kilograms per hour / day = tonnes per hour / day / year
Differential pressure (dP)	mbar // hPa // mmWS // inch Wa
Gas velocity (Vel) mS/S	
Volume velocity (Vols)	m ³ /s // m ³ /m // m ³ /h // m ³ /T // m ³ /J = cubic metres per second, minute, hour, day, year

1.4 Analog output box

1.4.1 General description

1.4.2 Configuring the analog output box using the Control Unit

1.4.3 Configuring the analog output box with PCMCIA systems

1. Description of the system components

1.4 Analog output box 1.4.1 General description

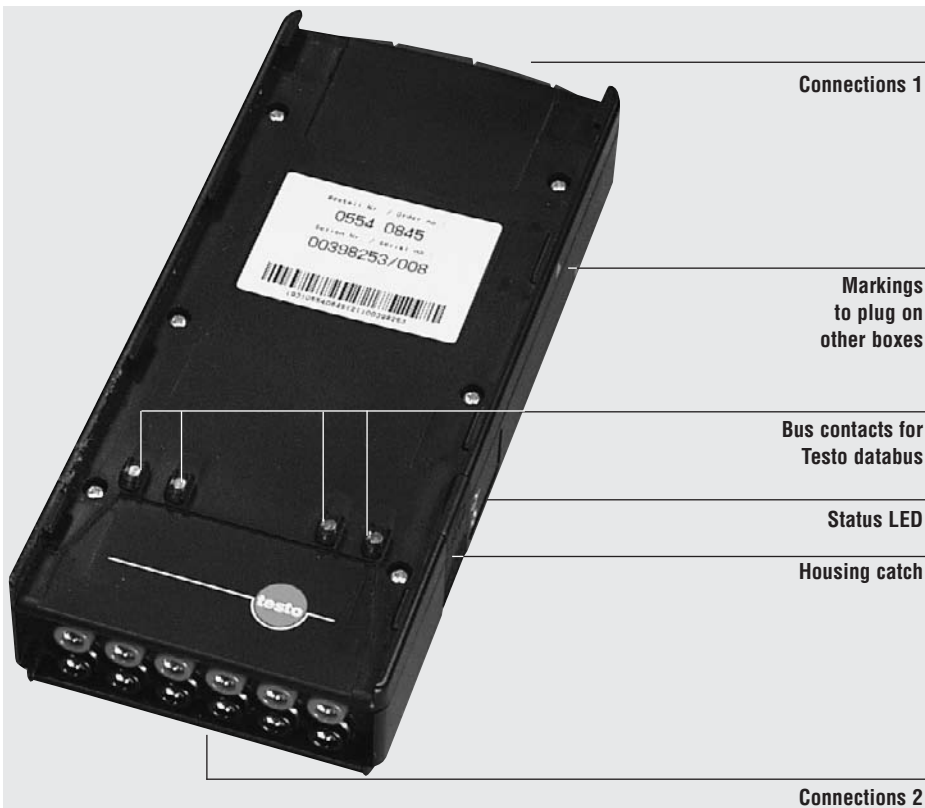

Connections 1

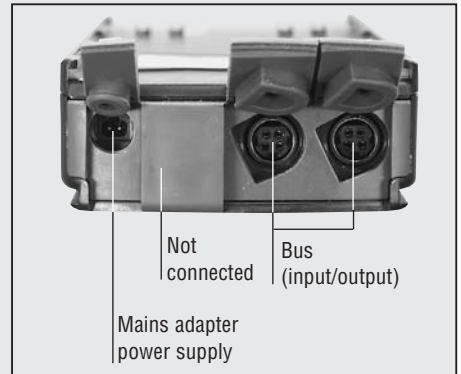

Connections 2

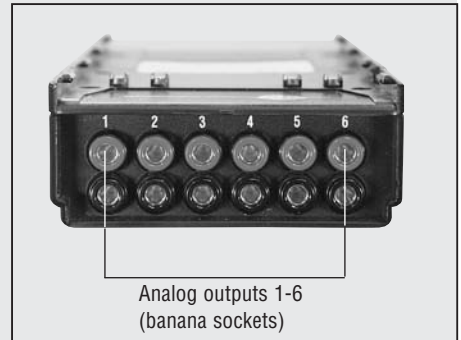

The analog output box is used to issue the analog signals of a selection of up to 6 measuring channels in complex measuring systems consisting of loggers and analyser boxes. For this, the different components must be connected by bus lines. The configuration of an analog box in the system is made either by the Control Unit or the PC software. The readings of the Control Unit cannot be issued by an analog output box.

A maximum of two analog output boxes can be logged onto one Testo databus system.

The analog outputs are current outputs, 4 to 20 mA. A load of 500 Ω per output is permissible.

Power supply

The analog output box is not equipped with its own power supply. It must be supplied by either an 8 V DC mains adapter (recommendation) or a power box interconnected in the Testo data bus.

The LED of the analog output unit lights green when the power supply is correct.

Bus connection

4 contacts each are located on the top and bottom of the housing to provide direct contacts to other plugged-on components. The bus connection can also be made by lines. The bus connection must not be disconnected under load conditions.

When the analog output unit has been connected to the Testo databus system, the 6 analog outputs can be configured either by the Control Unit or the PC software (incl. PCMCIA adapter or RS-232 cable).

Each individual output channel is assigned to a measuring channel; the range of the respective measuring channel is entered and is then represented by the 4 to 20 mA output of the output box on this channel. Depending on the load, 21-22mA is output if the measurement range is exceeded. Up to 3.5mA is output if the measurement range is fallen short of. The current value is set at 3.5mA as the starting value for a non-adjusted analog output box and in the case of a fault.

Connections

The channels are electrically isolated from the Testo data bus. The individual channels are not electrically isolated. Therefore, ensure when connecting that an unwanted mass loop does not occur.

Example:

Incorrect

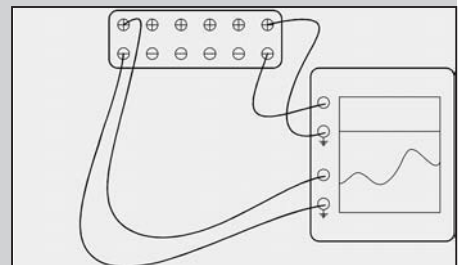

Since the inputs on the recorder are earthed, a short circuit occurs in the right channel.

Correct

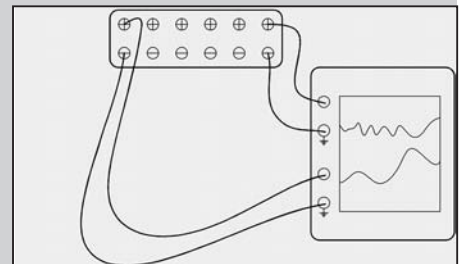

In the case of the two channels, the positive output is on the mass loop of the recorder. The interfaces function correctly.

1. Description of the system components

1.4 Analog output box

1.4.2 Configuring the analog output box with the Control Unit

If you have connected the Control Unit to one or more measuring units, an adequate power supply is provided. It may be necessary to connect a powerbox. An analog output unit is also installed in the system.

Press the “On/Off” button of the Control Unit to initialise the entire system. Press **OK** on the Control Unit and you will receive the units available on the Testo databus.

Select the analog output box with the cursor keys up and down and confirm with OK.

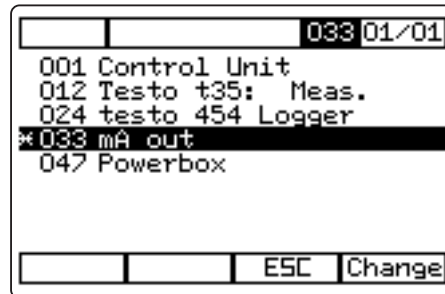

You can then access the instrument menu of the analog output unit with the scroll key.

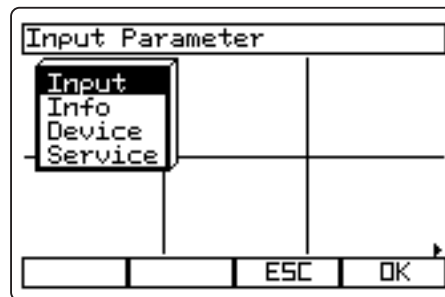

Select “Input” and confirm with “OK”. You will then receive a list of all instruments available in the system whose signals can be configured for the analog output box.



1. Description of the system components

1.4 Analog output box

1.4.2 Configuring the analog output box with the Control Unit

Choose one of the instruments. When you have confirmed this with **OK**, you will receive a list of the channels available to this unit. Now choose the channel to be issued by the analog output box.



You will then receive a list of the six output channels of the analog output box. Select the output to be configured with the previously chosen channel of the analyser box.

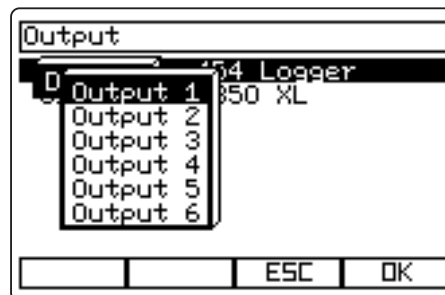

Finally, enter the reading of the channel for which the analog output box is to issue 4 mA, "Min. input". After confirming with **OK**, go to "Max. input" and enter the value corresponding to the 20 mA output of the analog output box.

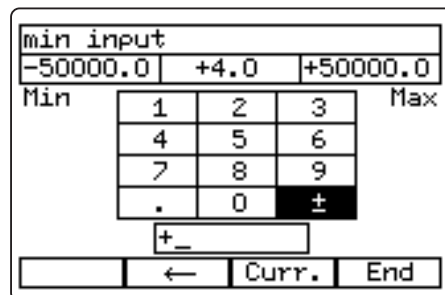

1. Description of the system components

1.4 Analog output box

1.4.3 Configuring the analog output box with PCMCIA systems

Connect all system components by plugging them onto each other or using databus lines.

Terminate the most distant bus subscriber with a terminal plug. Ensure an adequate power supply to the bus either by plugging in a databus mains adapter or by connecting a powerbox with a fully charged battery or a connected mains adapter.

System initialisation:

Start the software, click with the right mouse button on the **Bus connection** icon in the tree/data section and execute the **Open** command in the submenu.

All bus subscribers are then identified and listed. If an analog output box is connected, the icon for the analog output box also appears.

Click with the right mouse button on the icon of the analog box and select **Open**.

Click again with the right mouse button on the opened icon and select **Device control**.

This opens the main menu of the analog output box.

This screen provides basic information about this box. You can give the box its own name in the top line. If necessary, you can edit the bus address of the analog box in the bottom line. This is necessary when a component with the same address is already installed on the bus, making bus communications almost impossible.

Ensure that all components logged onto the system have different bus addresses.

Bus selection

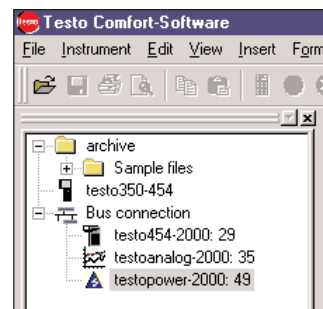

Analog overview

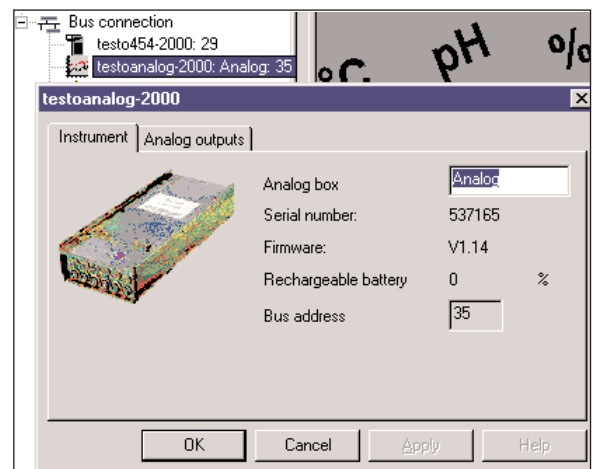

1. Description of the system components

1.4 Analog output box

1.4.3 Configuring the analog output box with PCMCIA systems

Then go to the register :

You will receive an overview of the 6 possible channels. These are not initially assigned to any measuring channel in the system.

Then open the selection list of the analog output to be assigned by clicking on .

You will then receive a list of all channels available in the Testo databus system.

Select one of the listed channels. A scaling facility is enabled on the right-hand side. The left number in the “from” column is then assigned to the lower current value of 4 mA; the right number in the “to” column represents the maximum current of 20 mA.

Click on or to store the data in the connected analog box.

In the system itself, currents are issued at the analog outputs as soon as online measurements are started whose channels have been configured in the analog box.

It is also possible to issue analog signals corresponding to a measurement in progress in a logger.

The analog data is updated at the highest possible rate of measurement, i.e. up to 1/sec.

Please note!

Due to the digital processing of the measurement data and the discrete time structure, sudden changes in the signal cannot always be avoided. Depending on the progress of time and the scaling, you may possibly receive vertical or parallel lines on the pen recorder parallel to the time axis.

It is therefore not advisable to use the analog outputs to control fast systems with time constants substantially lower than 1 minute.

Scaling

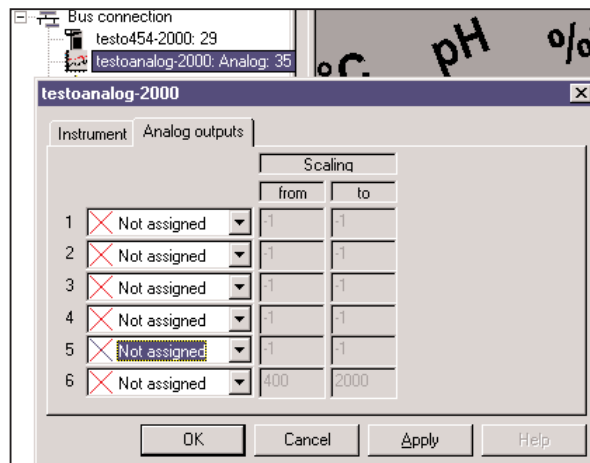

Example:

A scaling of 0 to 100 for a humidity measuring channel issues 4 mA at the analog output for 0 %RH and 20 mA for 100 %RH.

Note:

Ensure that you assign analyser boxes and their channels to the analog output box by this operation.

This allocation will only work when the system configuration and the hardware components are not changed afterwards.

This means that you will receive an error message if you remove instruments from the system which are referenced in the analog configuration.

You will also receive an error message if the box remains in the system, but is fitted with different probes and therefore different measuring channels and units.

1.5 Powerbox



1. Description of the system components

1.5 Powerbox

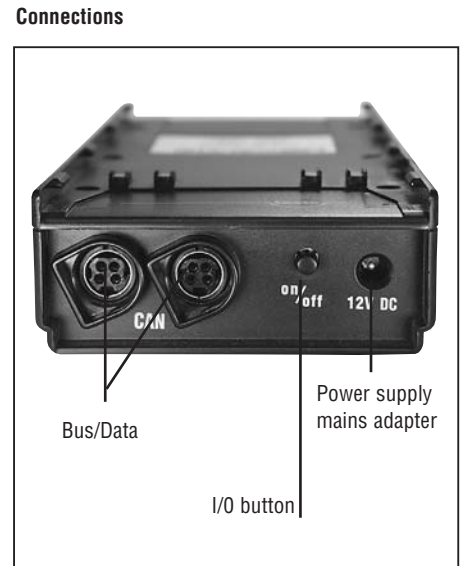

The testo powerbox is used to provide an additional supply of energy to a testo 454 logger system.

In a simple combination of equipment such as a control unit and one logger with various probes, the powerbox can be used as a simple means of extending the battery lifetime. In more complex systems with many components, it fulfils several tasks:

- It allows communication through the Testo databus by providing an electrical supply to the part of the bus galvanically isolated from the instrumentation.
- It provides an energy supply to the weakest connected bus subscriber.
- When plugged onto another system component, it provides two further bus connection sockets.
- Up to 3 A of current can be fed into the system by the power supply unit of the powerbox.
- With a full equipping with probes with high power consumption connected to the 4 sockets of a logger (e.g. 4 thermal probes or 4 CO₂ probes), the powerbox has a stabilising effect and makes measurements possible.
- In conjunction with an analog output box, it allows this to operate independently of the mains.

PC software

The powerbox appears in the PC software as an independent instrument in the system, i.e. when the bus has been initialised, the powerbox appears with its own icon beneath the bus icon and beside the connected loggers, flue gas analyser units and the analog output box.

After clicking with the right mouse key, it is also possible to open the device control of the powerbox. The data of the powerbox is then contained in the overview window for information purposes:
serial number, firmware version of the software and battery capacity.

A separate name can be entered which appears in the device list, and also the bus address on the Testo databus.

Please observe that each unit connected as a bus subscriber in the system must also have its own Testo databus ID number in this case. Otherwise, bus communications cannot be put into operation.

Caution!

It is essential that all bus ID addresses are different.

If the system is operated for longer periods, it is generally advisable to supply the powerbox from its own mains adapter. In typical applications, particularly for air conditioning systems (several loggers, analog output box...), the entire system connected to the powerbox can be supplied from the central mains adapter of the powerbox. (Limits must be taken into account, see below.)

If the external mains adapter of the powerbox is connected, the rechargeable batteries of the units connected to the Testo databus can also be charged from this central mains adapter.

In battery operation, the battery or the powerbox extends the running times of the individual subsystems and ensures a supply to the bus system to sustain communications.

Operation in the critical range

The number and types of boxes which can be supplied by a powerbox depend on various conditions. The following information is based on estimates.

A maximum output current of 3 A may be drawn from a powerbox. Otherwise, the powerbox switches the power supply off as a safety measure.

Current consumption	
The individual boxes draw the following currents from the bus supply:	
Control Unit:	minimum 70 mA, typically 300 mA, max. 750 mA Note: Maximum includes probes, battery charging and display lighting.
Logger without probes:	Max. 100 mA
Logger with probes:	Min. 150 mA, max. 1000 mA
Analog output box:	Typically 100 mA, max. 350 mA Note: 6 outputs @ 20 mA

A powerbox can supply up to 4 loggers.

It is generally recommended to place the supplying powerbox geometrically between the heavy consumers. A better method is to plug a powerbox directly onto each heavy consumer.

Because supply currents of up to 3 A can flow through the 4-pole Testo databus cable, the length of the bus connection cable is restricted to 50 m due to the voltage drop. A maximum system coverage of 100 m and above is made possible by reducing the currents between the interspaced units, i.e. the individual loggers and bus subscribers must have local supplies wherever possible, either from the batteries of the respective powerboxes or from local mains adapters.

The external mains adapter operates correctly up to a maximum bus load of 2.5A. Beyond this, the current limiting of the external mains adapter takes increasing effect.

If the mains adapter is disconnected during operation, the battery of the powerbox provides the power supply. Switching occurs without interruption.

The charging time in standard operation is approx. 3 hours.

Note:

The charging current in rapid charge mode is 2A. The temperature of the integrated nickel metal hydride batteries is constantly monitored during this by an integrated temperature sensor. A switch is also installed in the rechargeable battery pack itself which stops the charging current on overheating.

Rapid charge mode at high ambient temperatures (> 30 °C) is only possible to a limited extent due to the developing heat, as the heat produced during charging cannot be dissipated to the environment. At such temperatures, the charging time can be substantially prolonged, as charging is repeatedly interrupted to protect the batteries.

1. Description of the system components

1.5 Powerbox

Internal LED function display of the powerbox

Colour	Status	Bus voltage activated?
Green/steady	Mains operation, trickle charge	Yes
Yellow/steady	Mains operation, rapid charge active	Yes
Red/steady	Power supply overload (warning threshold) but box not yet automatically switched off (error state).	Yes
Green/flashing	Rechargeable battery operation	Yes
Yellow/flashing	Battery operation, battery low	Yes
Red/flashing	Fault status	Dep. on the fault
Off	Box is switched off.	No



In general:

If the LED is off, the box is switched off. The box and the connected Testo databus system can be activated with the ON/OFF switch of the powerbox.

The LED then lights continuously green in normal operation when the mains adapter is connected and flashing green in battery mode. All other colours and states indicate an operating status error.

1.6 Power supply

1.6.1 Power supply, analyser box/Control Unit

1.6.1.1 Mains operation

1.6.1.2 Rechargeable battery operation

1.6.2 Power supply, Control Unit

1.6.2.1 Mains operation

1.6.2.2 Battery operation

1.6.2.3 Rechargeable battery operation with standard batteries

1.6.3 Charging rechargeable batteries

1.6.3.1 Rechargeable battery charging, analyser box/Control Unit

1.6.3.2 Charging the rechargeable battery pack (Control Unit)

1. Description of the system components

1.6 Power supply

1.6.1 Power supply, analyser box/Control Unit

1.6.1.1 Mains operation

Plug mains cable into analyser box. The power supply for the Control Unit is ensured when the:

- Control Unit is connected to the analyser box by the contact strips or
- Control Unit is connected to the analyser box by the Testo databus cable

1.6.1.2 Rechargeable battery operation

The power supply for the Control Unit in rechargeable battery operation is ensured when the:

- Control Unit is connected to the analyser box by the contact strips or
- Control Unit is connected to the analyser box by the Testo databus cable

Caution! Observe the rechargeable battery capacity.

Note:

Batteries or rechargeable batteries have to be used to set up the databus connection in the control unit.

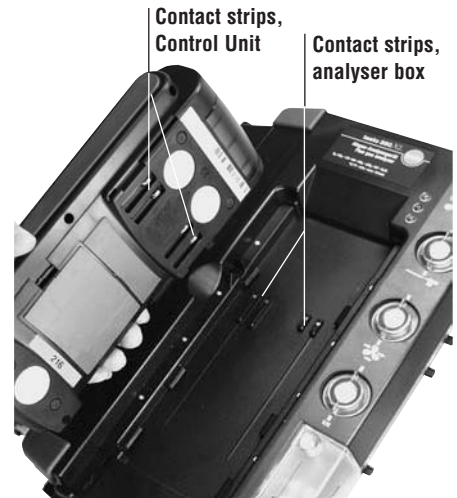

1. Description of the system components

1.6 Power supply

1.6.2 Power supply, Control Unit

1.6.2.1 Mains operation

Connect mains adapter to the Control Unit.



1.6.2.2 Rechargeable battery operation

Either with standard rechargeable batteries or with the testo rechargeable battery pack (art. no. 055.0097)
Please observe the rechargeable battery capacity!



1.6.2.3 Rechargeable battery operation

Observe the battery capacity and polarity!
The batteries can remain in the instrument during mains operation.



1. Description of the system components

1.6 Power supply

1.6.3 Charging rechargeable batteries

1.6.3.1 Rechargeable battery charging, analyser box/Control Unit

The rechargeable battery packs must be installed in the analyser box and the Control Unit for charging.

Plug the mains cable (230 V AC) into the analyser box.

The charging of the rechargeable battery pack for the Control Unit is ensured when the:

- Control Unit is connected to the analyser box by the contact strips or
- Control Unit is connected to the analyser box via the Testo databus line

During charging:

- LEDs in the analysis measuring box:
 - LED1 lights up green/permanent (mains operation)
 - LED3 lights up green/flashing (battery recharging) or green/permanent (recharging battery full)
- Display of recharging capacity of control unit rechargeable battery in control unit display



Note:

The instruments must be switched off.
Charging is impossible during operation.

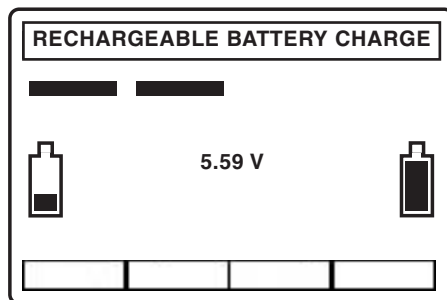

Status display of LED in flue gas analyser box	
LED1 (Power):	
Mains operation	Green/Permanent
Battery operation (Batt. full)	Green/Flashing
Battery operation (Batt. empty)	Red/Flashing
Battery recharging, Off mode	Off
LED2 (Status):	
Measuring	Green/Permanent
Fresh air mode/Zeroing	Green/Flashing
Error	Red/Flashing
LED3 (Battery recharging):	
Battery recharging (Fast recharging)	Green, flashing
Battery full, compensation charge	Green, permanent

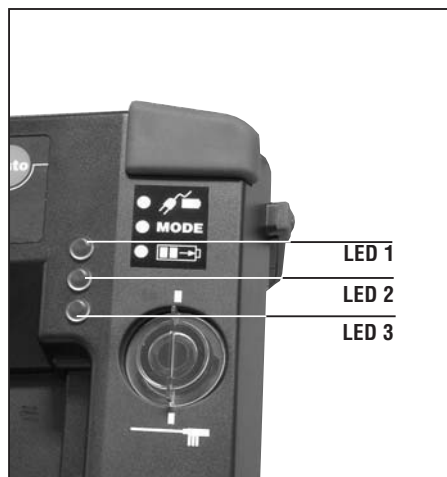

1. Description of the system components

1.6 Power supply

1.6.3 Charging rechargeable batteries

1.6.3.2 Charging the rechargeable battery pack (Control Unit)

The rechargeable battery pack must be installed in the Control Unit for charging.

Observe the polarity of the plug when inserting.

Avoid crushing or kinking the lines.

Standard rechargeable batteries cannot be charged.

Plug the mains adapter into the Control Unit.

During charging:

- The charged capacity is indicated on the Control Unit display.

Caution!

Spent rechargeable battery packs, standard rechargeable batteries and batteries must be disposed of as toxic waste.

Caution!

The marking of the testo rechargeable battery pack must be visible when the housing lid is opened.



Note:

The Control Unit must be switched off.
Charging is impossible during operation.

testo rechargeable battery pack

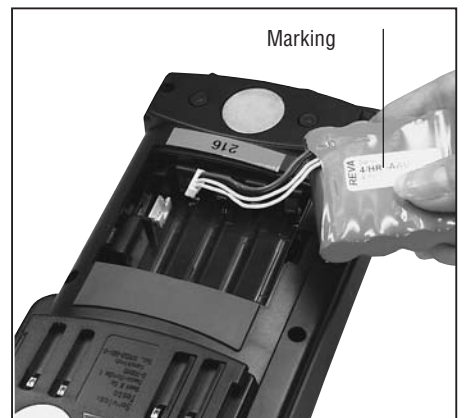

1.7 PC plug-in card

1.7.1 General description

1.7.2 Description of the system component
RS-232 in conjunction with set 1

1.7.3 Description of the system component
PC plug-in card – set 2

1. Description of the system components

1.7 PC plug-in card/Comsoft 454/350

1.7.1 General description

The PC software for the system 350/454 is used to configure and program connected hardware components and to read, view and archive the data and measurement sequences stored in the analyser units.

There are two general ways of accessing the hardware components:

Set no. 0554.0841 (set 1), Comfort-Software V3.1 with RS-232 connecting cable: This set is used primarily to connect the control unit to the PC. Beyond this, other analyser units connected on the Testo databus can be controlled and evaluated via the control unit from the PC. All subscribers can be accessed by the RS-232 communications, although access is always made to one individual subscriber. The concurrent operation of several loggers with a freely definable, mixed, online channel display as with set 2 is impossible.

Set no. 0554.0590 (set 2), consisting of PCMCIA card, installation software with operating instructions, data line and bus connection line. Also in the set: the testo Comfort-Software, version 3.1 or higher. This set provides direct access to the Testo databus. One or more loggers or analyser boxes can be connected concurrently to the PC/laptop with the supplied data cable. Access to the hardware components is made by the testo Comfort-Software. The device drivers required for this are supplied on the CD-ROM contained in the delivery.

What can the two sets do?

- Data management in a hierarchical tree structure
- Preparation of complex measurements by assigning locations, names, channel designations and other descriptive information.
- Control of the connected and selected instruments
- Definition of measuring programs and storage of these in the devices
- Reading of various devices, consolidation of their data in individual reports, evaluation, printing and archiving.
- Adjustment of system data and settings (units, date/time...)
- Online measurement with the connected and selected logger

Additionally with set 2:

- Multi-device bus operation with a means of online, mixed display of selected channels from numerous connected loggers.
- Global setting and evaluation of alarm and trigger signals.

Software versions

The software version which you are using is indicated in the Info window when the program is loading.

This description applies to the Comfort-Software V3.1, testo 350/454 and compatible modules.

1. Description of the system components

1.7 PC plug-in card/Comsoft 454/350

1.7.1 General description

Minimum system requirements

- PC with operating system Microsoft Windows 95® or higher (if compatible)
- Microsoft Windows NT® 4, Service Pack 4 or higher (if compatible),
- Windows 2000® or higher (if compatible)
- CD-ROM drive
- Pentium 100 MHz
- 32 MB RAM
- 15 MB unused hard drive capacity
- Unused serial interface (COM) or corresponding adapter for set 1
- PCMCIA slot in a laptop or corresponding PC module for set 2

Installation of Comsoft for 454/350

Insert the CD-ROM in the drive.

The installation menu opens automatically after a short time. If not, please double click "Setup.exe" on the CD-ROM.

You will be requested to enter the licence number (label comes with CD-ROM). If you are installing for the first time, it may be necessary to reboot the computer.

When you have confirmed this, the installation procedure continues and you will be requested to enter your name and your company.

The remainder of the procedure is menu-guided. Please observe the instructions and explanations beside the buttons.

General knowledge required to install and use the software

The user interface of the software (the appearance and structure) is defined according to the Microsoft Office® Standard. Icons and menu items are specified according to this standard. If you already use Office programs (Word®, Excel®, PowerPoint®...), you will quickly become familiar with the user interface.

The explanations made in the chapter "Applications" mainly describe the peculiarities of the 350/454 driver and the operation of the hardware components connected on the Testo databus. For introductory examples and a general description of the evaluation and printing of data, please see the operating instructions for testo Comsoft 454/350 (see chapter 1.8).

Note:

If the entered number is not accepted,

- Has the Caps Lock key been pressed inadvertently?
- Is "NUM" deactivated on the numeric keypad?
- Has "1" been accidentally entered in place of 1?
- Has "0" been accidentally entered in place of 0?

Note:

If you activate "protected" during installation, the register card "Range of functions" is not visible to the user and is not available later.

1. Description of the system components

1.7 PC plug-in card/Comsoft 454/350

1.7.2 Description of system component RS-232 in conjunction with set 1

Commissioning, connecting the device

After you have connected the measuring instrument, probes and all other system components together, connect the control unit with the supplied RS-232 cable to the COM port of your laptop/PC. Make another precautionary check of the bus power supply. It must be ensured that all system components have an adequate supply. Connect a powerbox either with a bus line or by plugging directly onto the system. Alternatively, you can connect a bus mains adapter directly to a 4-pole databus socket of the unit.

For supply with powerbox:

- Push the button to switch on the powerbox.
All connected system components indicate a ready state with the green LED (steady on or flashing).
- Switch on the control unit
- Start Windows® on the PC/laptop
- Start the testo Comfort-Software

First, select sub-item **New Instrument** of menu item **Instrument**.

1. Description of the system components

1.7 PC plug-in card/Comsoft 454/350

1.7.2 Description of system component RS-232 in conjunction with set 1

A list of the possible instruments is then presented. Select “testo 350-454” and follow the instructions on the screen, completing the device set-up by pressing the key.

A device icon named testo 350-454 then appears in the list on the left of the screen.

Open the device driver by double clicking on the icon and then choose one of the components listed in the system: The available instruments are displayed in the list.

After selecting one, you will be given access to the device control of the selected instrument.

Further explanations with examples are to be found in the chapter “Applications”.

In particular, the topics “Evaluating and printing data” are to be found in Chapter 1.8.

1. Description of the system components

1.7 PC plug-in card/Comsoft 454/350

1.7.3 Description of system component PC plug-in card –Set 2

Commissioning, connecting the device:

Insert the PCMCIA card in the appropriate slot.

Connecting to the Testo databus: Plug the flat connector into the PCMCIA card. Then connect the adapter from 9-pole Sub-D to the 4-pole testo data plug to this. This must then be plugged into the instrument socket marked "Data".

Install the bus driver on your PC/laptop using the 3.5" diskettes.

Connect the probes to the measuring instrument.

Provide the Testo databus power supply by connecting a powerbox either by a bus line or by plugging directly onto the instrument or by connecting the bus mains adapter directly to the 4-pole data socket of the instrument.

For supply with powerbox:

- Press the button to switch on the powerbox.
- All system components connected to the Testo databus indicate a ready state with the green LED (steady on or flashing).
- Start Windows® on the PC.
- Start the testo Comfort-Software.

The Testo databus icon for the installed PCMCIA card first appears on the left in the archive section beside the folder with demo and example files.

When you click with the right mouse button on this icon, a menu window opens. In this, execute the command .

The BUS is then searched for the connected subscribers. These are listed under the icon "Bus connection".

The system is then ready to operate. You can then program, configure and read each connected device individually by clicking on the device and opening the context menu with the right mouse key using the item "Device control". You can also create a further "Virtual device" group by clicking on the bus icon, in which you can select the measuring channels to be displayed in an online measurement from the presented list.

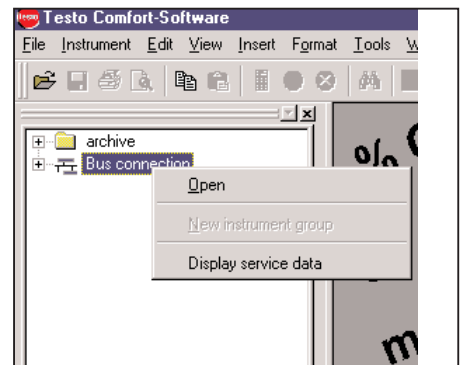
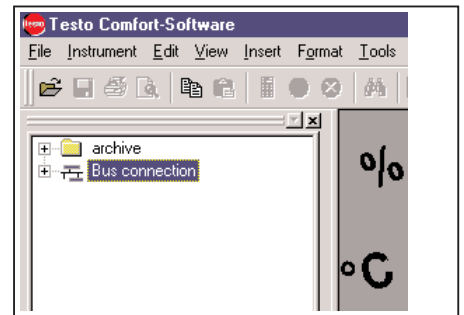

1.8 Comsoft 454/350

1.8.1 Licence Agreement

1.8.2 Installation

1.8.2.1 Minimum system requirements

1.8.2.2 Installation

1.8.2.3 General information on using and installing software

1.8.3 1st session – Brief instructions

1.8.3.1 Mouse functions

1.8.3.2 Toolbars and palettes

1.8.3.3 Toolbars

1.8.3.4 Toolbars, our recommendation

1.8.3.5 Menu layout: Main menu

1.8.3.6 Menu layout: Context menus

1.8.3.7 Online help

1.8.4 Example 1

1.8.4.1 Demo file without instrument

1.8.5 Example 2

1.8.5.1 testo 350/454 and humidity probe, logging measurement sequence

1.8.5.2 testo 350/454 and humidity probe, analysing measurement sequence

1.8.5.3 testo 350/454 and humidity probe, exporting saved data

1.8.6 Example 3

1.8.6.1 testo 350/454 and humidity probe, direct display of readings

1.8.7 Error messages

1.8.8 Details/Backgrounds

1.8.8.1 Display ranges

1.8.8.2 Main menu item: "File"

1.8.8.3 Main menu item: "Instrument"

1.8.8.4 Main menu item: "Edit"

1.8.8.5 Main menu item: "View"

1.8.8.6 Main menu item: "Insert"

1.8.8.7 Main menu item: "Format"

1.8.8.8 Main menu item: "Tools"

1.8.8.9 Main menu item: "Window"

1. Description of system components

1.8 Comsoft 454/350 1.8.1 Licence Agreement

This is a legally valid contract between you, the end user, and Testo. When you or a person authorised by you opens the sealed CD-ROM package, you recognise the provisions of this contract. If you do not agree with the terms and conditions, you must immediately return the unopened software package with the accompanying items, including all written documents and other containers, to the place from which you bought the software, which will give you a full refund of the purchase price.

Granting of a licence

This licence entitles you to use a copy of the Testo software which was acquired with this licence on a single computer subject to the condition that the software is only ever used on one single computer at any one time. If you have bought multiple licences for the software, you may only have as many copies in use as you have licences. The software is "in use" on a computer if it is loaded in the intermediate memory or RAM or stored on a permanent memory, e.g. a hard disk, of this computer, with the exception that a copy which is installed on a network server for the sole purpose of distribution to other computers is not "in use". If the foreseeable number of users of the software exceeds the number of licences acquired, you must ensure, through the necessary mechanisms or procedures, that the number of persons using the software at the same time does not exceed the number of licences.

Copyright

The software is protected against copying by copyright laws, international agreements and other legal provisions. You may not copy the software, the handbooks for the product or any other written documents accompanying the software. The software may not be licensed, let or leased to third parties. If the software is not fitted with a dongle, you may either make a single copy of the software solely for backup or archiving purposes or transfer the software to a single hard disk, provided that you keep the original solely for backup or archiving purposes. You are not permitted to reverse engineer, decompile or disassemble the software. Testo GmbH & Co., Lenzkirch, may take legal action against you for any breach of property rights by you or by any person acting, directly or indirectly, under your authority.

Limited guarantee

Testo guarantees for a period of 90 days from purchase of the software by the buyer, or for a longer minimum period if such a period is prescribed by the laws of the country in which the product is sold, that the software conforms to general standards defined in the accompanying documentation. Testo expressly does **not** guarantee that the software will operate without interruption or without errors. Should the software not function according to the accompanying documentation when in normal use, the buyer will have the right to return the software to Testo within the warranty period and to inform Testo in writing of the deficient functional capacity. Testo will only be bound to make a functional copy of the software available to the buyer within a reasonable period of time from receipt of the notification of functional incapacity or, should a copy not be available for any reason, to reimburse the buyer for the purchase price.

Any warranty in respect of the software, the associated manuals and written material extending above and beyond the limited guarantee outlined above is excluded.

Neither Testo nor the suppliers of Testo are liable to pay compensation for any losses arising as a result of use of this Testo product or the inability to use this Testo product, even if Testo has been informed of the possibility of such a loss. This exclusion does not apply for losses occasioned through intent or gross negligence on the part of Testo. Claims founded on mandatory statutory provisions regarding product liability are likewise unaffected.

Copyright © 2001, Testo AG

Microsoft Windows® and Excel® are registered trade marks of Microsoft Corporation

1.8.2.1 Minimum system requirements

- PC with operating system
 - Microsoft® Windows® 95 or higher (if compatible)
 - Microsoft® Windows® NT 4, Servicepack 4, or higher (if compatible).
 - Windows® 2000 or higher (if compatible).
 - Windows XP or higher (if compatible).
- CD-Rom drive
- Pentium 100 MHz
- 32 MB RAM
- 15 MB hard disc drive space free
- Free serial interface (COM) or corresponding adapter.

1.8.2.2 Installation

1. Place CD-ROM in drive.
2. The installation menu will start up after a short time. If it fails to start, double-click on "Setup.EXE" on the CD-ROM.
3. You are asked to enter the licence number (see sticker under CD-ROM). Restart may be necessary if it is the first installation.
Note: If the number input is not accepted it may be due to the following:
 - Is the Caps Lock activated?
 - Is "Num" in the separate digit pad not activated?
 - Was l entered instead of 1?
 - Was o entered instead of 0?
4. Once confirmed, the installation continues and you are asked to enter your name and company name.
5. The rest of the procedure is then menu-driven. Please observe the notes and explanations beside the buttons.

Note:

If



"protected" is activated, the "Range of functions" register is not visible to the user and will not be available later.

1.8.2.3 General information on using and installing software

The software interface (appearance, operation philosophy) is defined in accordance with the Microsoft® Office Standard. Symbols and menu items are selected analog to this standard. Therefore, if you are already working with Office programs (Word®, Excel®, PowerPoint® ...), you will very quickly become familiar with the interface.

1. Description of the system components

1.8 Comsoft 454/350

1.8.3 1st session –Brief instructions

1.8.3.1 Mouse functions

Certain menu functions can be activated directly via the mouse, making the software easy to use.

Some menu functions need only to be clicked on once with the mouse while others need to be clicked twice.















The following options are available depending on where you are in the program:

Mouse functions	
Mouse action	Menu function
Click left on menu item:	Opens sub-menu or carries out function
Click left on symbol button:	Carries out function
Click left on name in archive:	Selects
Double-click, left:	Selects and opens/activates
Click right:	Opens (if available) Context menu

1. Description of the system components

1.8 Comsoft 454/350 1.8.3 1st session –Brief instructions













1.8.3.2 Toolbars and palettes

Symbols	
File category	
Open file	
Save active document	
Page view	
Print view	
Set up new location	
Set up new folder	
Transmit to instrument	
Delete element	
Undo last action	
Copy to clipboard	
Paste clipboard contents	
Set up formula	
Connect protocols	
Use help	
Use context-sensitive help function	













1. Description of the system components

1.8 Comsoft 454/350 1.8.3 1st session –Brief instructions

1.8.3.2 Toolbars and palettes

Symbols	
Instrument category	
Device control	
Control measurement	
Start online measurement	
Stop online measurement	
Read out memory	
View category	
View as diagram	
View as table	
View as digit box	
View as histogram	
View as form	
View as analog instrument	
View as parametric graph	
Set layout	<input type="text"/>
Search in archive	

1.8.3.2 Toolbars and palettes

Symbols	
Left mouse button selects	
Left mouse button shows status info.	
Left mouse enlarges	
Left mouse button shows crosshair	
Left mouse button marks area to be included in mean calculation	
L. mouse button shows compens. curve	
Left mouse shows difference	
Select font	
Change background colour in diagram – Also edits pattern/style	
Insert text	
Remove text from a view	
Full screen display	

1. Description of the system components

1.8 Comsoft 454/350

1.8.3 1st session –Brief instructions

1.8.3.3 Toolbars

You can directly activate commands, which are often used by selecting the icons in the toolbars.



You can easily move the required toolbar to another position using the mouse. It will appear horizontal, vertical or as a separate window (palette) depending on the position.

You can determine the function of the toolbars in the **Tools/Customize** menu.

You can put together new toolbars on the register available and define

- whether the toolbar should be displayed or not.
- whether large or small buttons are to be used.
- which icons are to appear in the toolbar.
- which special functions are to be in the menus.

To change the toolbars, open the “Commands” register and move the corresponding icon to the desired location in the toolbar. Click at the bottom of the symbol for more information. To delete icons, simply pull them away from the toolbar.

Separation marks can be placed between the icons. Simply move an icon to the side of the toolbar to remove or insert the marks.

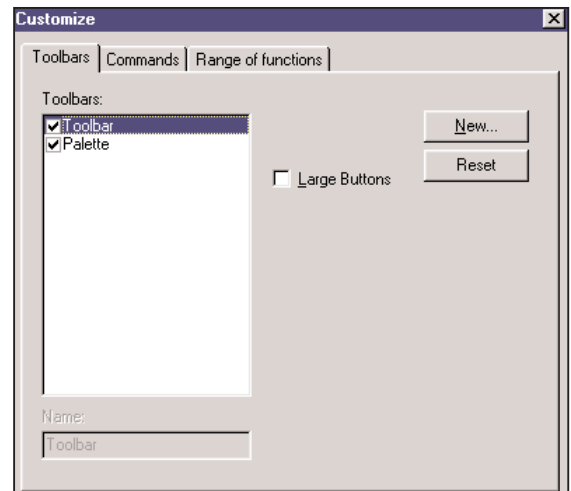

1. Description of the system components

1.8 Comsoft 454/350

1.8.3 1st session –Brief instructions

1.8.3.4 Toolbars, our recommendation

You can put together your own toolbar as required. The following are some suggestions:

easy Logger operation

The functions suggested here are used regularly to program and read out data loggers and should therefore be placed in the toolbar for direct access.

Main emphasis: Data management

Regular reworking and updating of the archive tree is necessary in this case.

The tools specified here are particularly suitable for this purpose .

Main emphasis on printed documentation

Read out instrument and print as table or diagram - the range of functions should be reduced accordingly if no longer in use.

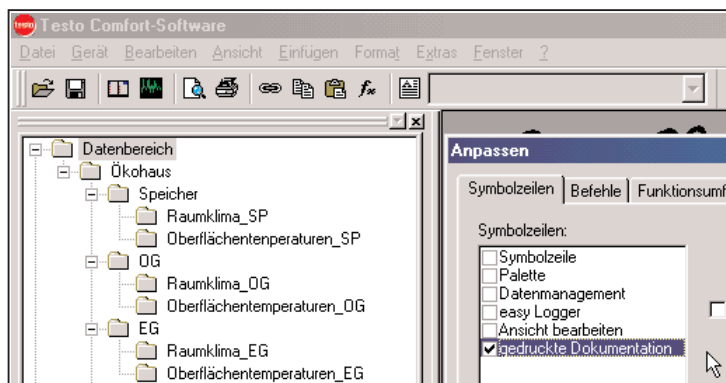
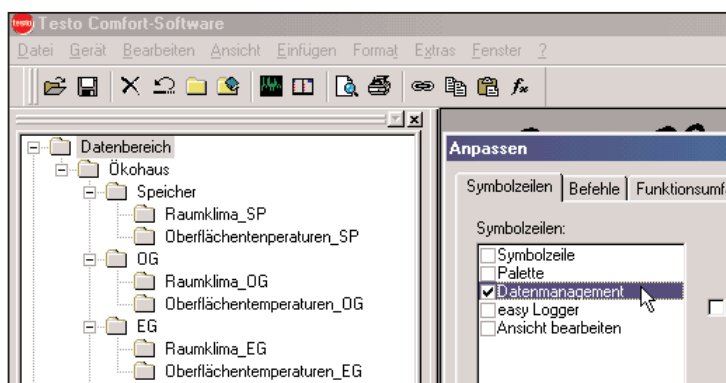
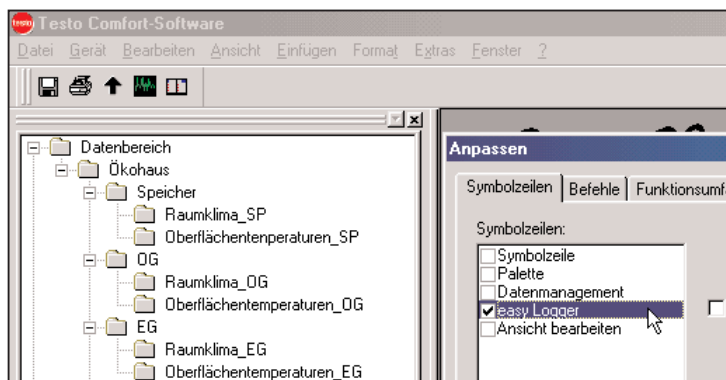

1. Description of the system components

1.8 Comsoft 454/350

1.8.3 1st session –Brief instructions

1.8.3.5 Menu layout: Main menu

Going from left to right, the main menu contains the following:

File

All of the functions which are needed to open, close, save, delete and print. New folders and locations are created. The names of files and folders can be changed and their properties can be displayed.

The files which were last used are available in a list which can be opened.

The program can be exited in this menu.

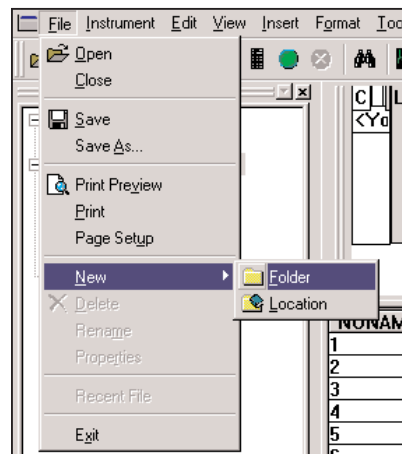

Instrument

Connection to the measuring instruments is controlled from this menu. New measuring instruments can be connected and configured.

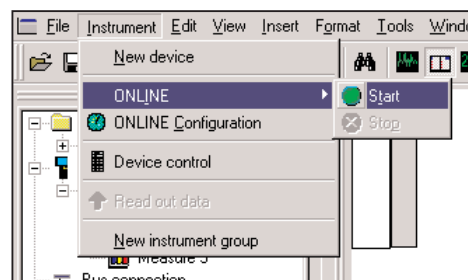

Edit

Readings can be copied, inserted, pasted or deleted using these commands (also self-defined mathematical functions).

Commands can be undone.

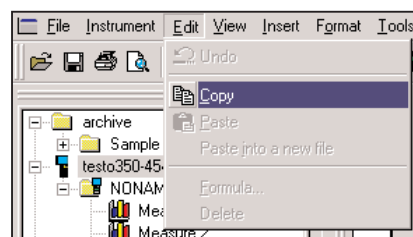

1. Description of the system components

1.8 Comsoft 454/350

1.8.3 1st session –Brief instructions

1.8.3.5 Menu layout: Main menu

View

Included are functions required for graphical display or screen layout. Toolbars, status bars, archive or palettes can be made to appear or disappear, as required. You can choose which channels of the attached instrument are to be shown and a protocol header can be defined.

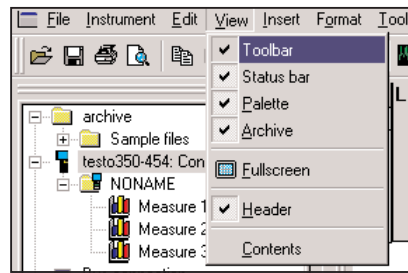

Insert

Text can be added to diagrams. The readings can be further offset using a mathematical function.

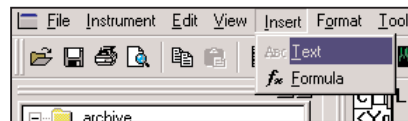

Format

The font can be set here. This font is then used for protocols and to label diagrams.

The appearance of the diagrams and tables can be improved optically using specific patterns/ styles.



Tools

Settings:

Here you have the option of assigning units and axes.

Customize:

It is also possible to define the range of functions included in the toolbar.

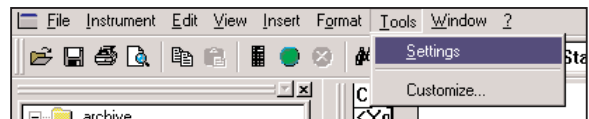

Window

If you have several files at the same time stored in the RAM, you have several ways available to display them.

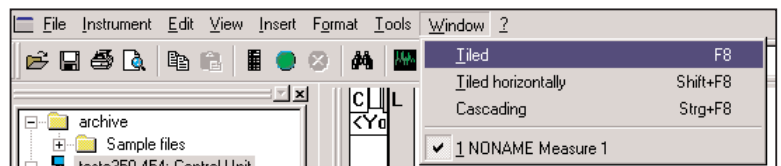

1. Description of the system components

1.8 Comsoft 454/350

1.8.3 1st session –Brief instructions

1.8.3.6 Menu layout: Context menus

This is a special range of commands selected especially for a certain area. These menus, which can be selected using the right mouse button, can be opened depending on where the mouse is placed.

Context: Instrument

New locations can be quickly set up in the instrument, the current instrument can be registered and unregistered or all of the settings in the instrument can also be undertaken via “Device control” in the PC.

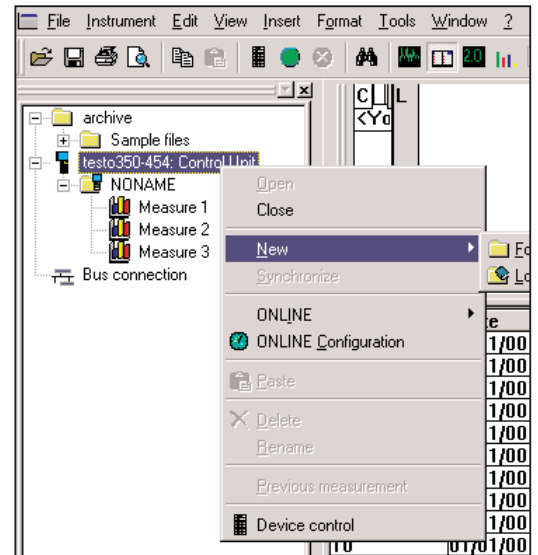

Context: Folders in archive

Click the right mouse button on the folder and then you can edit the tree structure:
Set up, delete, rename folder/locations etc.

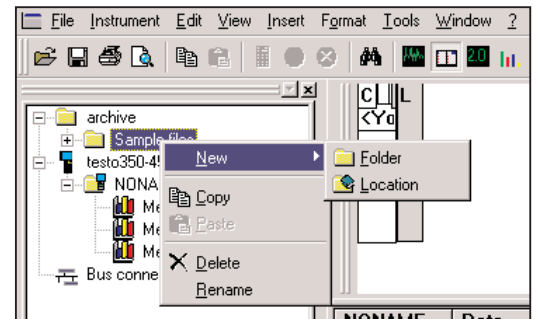

Context: Folders in instrument

The locations saved in the instrument can be edited.

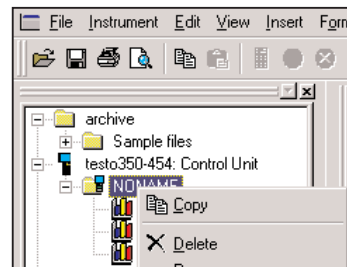

1. Description of the system components

1.8 Comsoft 454/350

1.8.3 1st session –Brief instructions

1.8.3.6 Menu layout: Context menus

Context: Location

- Edit contents
- Change/delete location name
- Edit information on location

Additional parameters or useful information (if supplied by the instrument), particularly on location, can be entered via “Properties”. These are also available on site once they are transmitted to the instrument. If you select more than one location, a menu to edit and printout barcode labels can be made to appear by pressing the right mouse button.

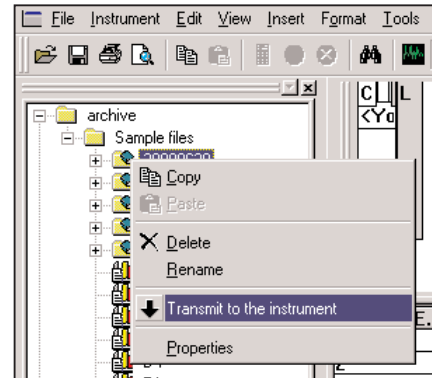

Context: Work area

In the work area context e.g. table, the data which is shown or is to be printed can be defined. Channels can be made to appear or disappear via Edit. Additional information for printing can be formulated via “Header”.

NONAME...	Date	Time	Pa		
1	01/01/00	04:54:54	0.89		
2	01/01/00	04:55:04	1.35		
3	01/01/00	04:55:14	1.56		
4	01/01/00	04:55:24	-0.55		
5	01/01/00	04:55:34	-1.27		
6	01/01/00	04:55:44	-1.86		
7	01/01/00	04:55:54	-0.84		
8	01/01/00	04:56:04	0.51		
9	01/01/00	04:56:14			
10	01/01/00	04:56:24			
11	01/01/00	04:56:34			
12	01/01/00	04:56:44			
13	01/01/00	04:56:54			
14	01/01/00	04:57:04			
15	01/01/00	04:57:14			
16	01/01/00	04:57:24			
17	01/01/00	04:57:34			
18	01/01/00	04:57:44			
19	01/01/00	04:57:54			
20	01/01/00	04:58:04			
21	01/01/00	04:58:14			
22	01/01/00	04:58:24			
23	01/01/00	04:58:34			
24	01/01/00	04:58:44	FL01		

1. Description of the system components

1.8 Comsoft 454/350

1.8.3 1st session –Brief instructions

1.8.3.6 Menu layout: Context menus

Context: Name of table

The context for the header in the table enables access to the title and information box, which can be edited in “Location”. “Measuring protocol” includes additional data on the protocol itself.

NONAME...	Date	Time	Pa			
1	01/01/00	04:54:54	0.89			
2	01/01/00	04:55:04	1.35			
3	01/0					
4	01/0					
5	01/0					
6	01/0					
7	01/0					
8	01/0					
9	01/0					
10	01/0					
11	01/0					
12	01/0					
13	01/0					
14	01/0					
15	01/0					
16	01/0					
17	01/0					
18	01/0					
19	01/0					
20	01/0					
21	01/0					
22	01/0					
23	01/0					
24	01/0					
25	01/01/00	04:58:54	1.18			

Context menu in diagrams and other presentation elements:

“Edit Line” leads to the settings menu for presenting the data and editing curves.

Note: This menu can be reached directly by clicking twice on the curve.

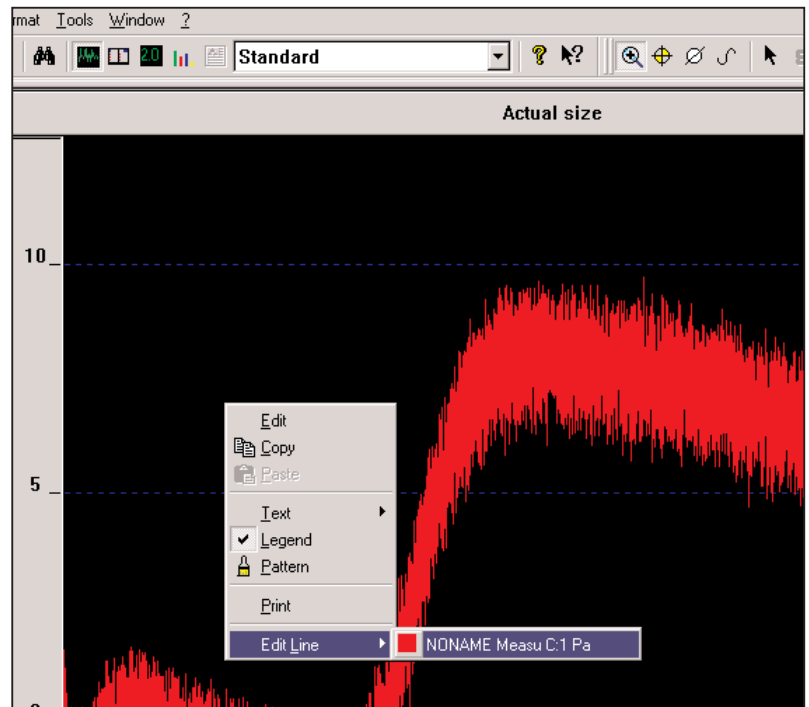

Short menu in digit box

Type of view, pattern/style and content can be selected.

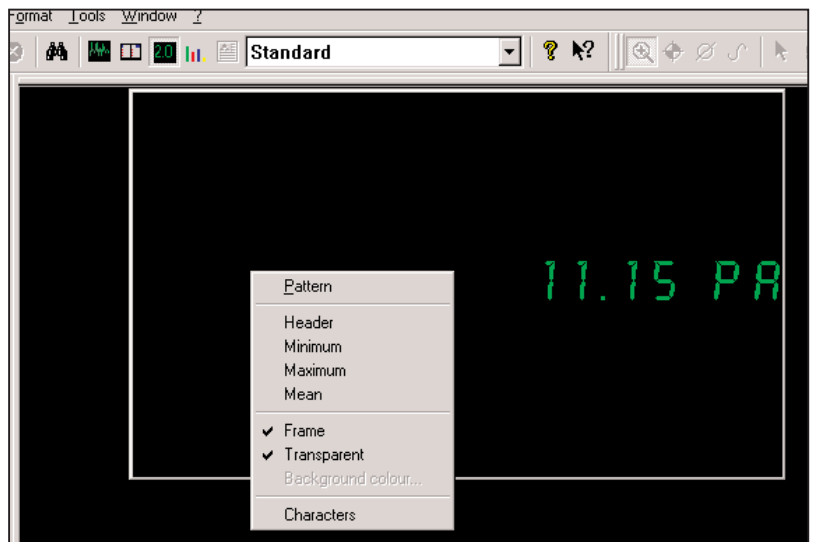

1. Description of the system components

1.8 Comsoft 454/350

1.8.3 1st session –Brief instructions

1.8.3.7 Online help

Online help is available for many functions. This online help is activated by pressing F1 (function button on the keypad) or by clicking on “?” in the menu bar.

Press Shift + F1 for direct help. The cursor arrow will then turn into a question mark with an arrow. You should click on the area about which you have a question. The online help for this topic will then be opened.

1. Description of the system components

1.8 Comsoft 454/350 1.8.4 Example 1

1.8.4.1 Demo file without instrument

Readings has to be opened first before it can be shown graphically.

The data is located in the memory of testo instruments or in a directory on a PC data medium for data which has already been filed (in this case: demo files).

Once the “File” menu item has been selected, the “Open” menu element is selected.

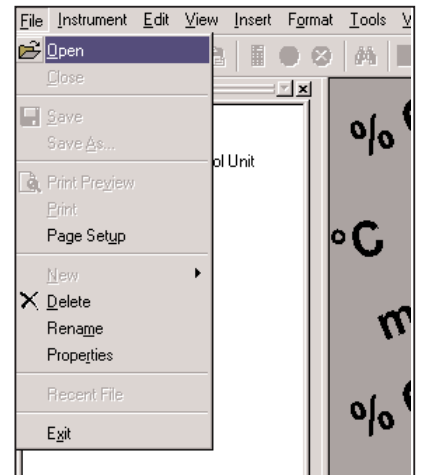

The **File/Open** dialog mask then appears.

A drive or a folder can be selected in the top part of the dialog mask. A list with file names appears in the middle part. The type of files required is selected in “Files of type”.

The following file types are available:

- *.vi2 Standard files, created by Comsoft 3
- *.prn Files from the software versions 2.51 and older, saved as ASCII text file
- *.WKS Files from the software versions WKS 2.51 and older, saved as WKS
- *.* All files.
- *.viw View files from earlier software versions that are no longer available.

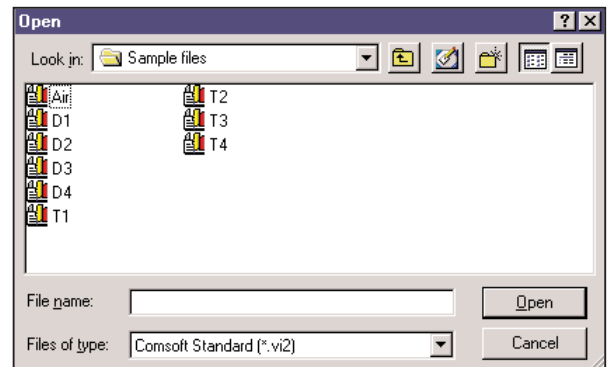

A file name is selected and is opened by clicking on it twice or clicking on the **Open** button.

1. Description of the system components

1.8 Comsoft 454/350 1.8.4 Example 1

1.8.4.1 Demo file without instrument

You can determine what form the measurement protocol is to appear in by clicking on one of the following: “Table”, “Digit box”, “Analog instrument”, “Diagram”, “Histogram” or “Parametric Graph”.



Diagram

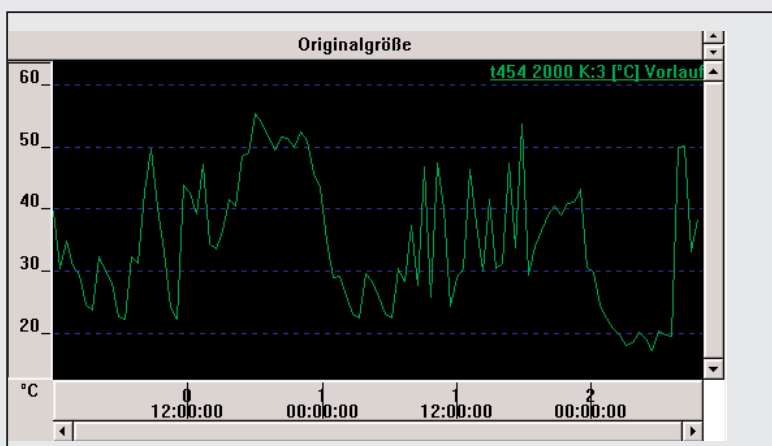

Table

testo454-...	Datum	Uhrzeit	[°C] ...	[hPa] ...
1	15.05.01	08:43:46	22,34	0
2	15.05.01	08:43:47	22,31	0
3	15.05.01	08:43:48	22,29	0
4	15.05.01	08:43:49	22,27	4
5	15.05.01	08:43:50	22,28	0
6	15.05.01	08:43:51	22,25	6
7	15.05.01	08:43:52	22,33	7
8	15.05.01	08:43:53	22,28	7
9	15.05.01	08:43:54	22,27	-0
10	15.05.01	08:43:55	22,24	-0
11	15.05.01	08:43:56	22,24	-1
12	15.05.01	08:43:57	22,23	3
13	15.05.01	08:43:58	22,27	3
14	15.05.01	08:43:59	22,24	0
15	15.05.01	08:43:59	22,26	-0
16	15.05.01	08:44:01	22,23	0
17	15.05.01	08:44:02	22,28	-0
18	15.05.01	08:44:03	22,28	5

1. Description of the system components

1.8 Comsoft 454/350

1.8.4 Example 1

1.8.4.1 Demo file without instrument

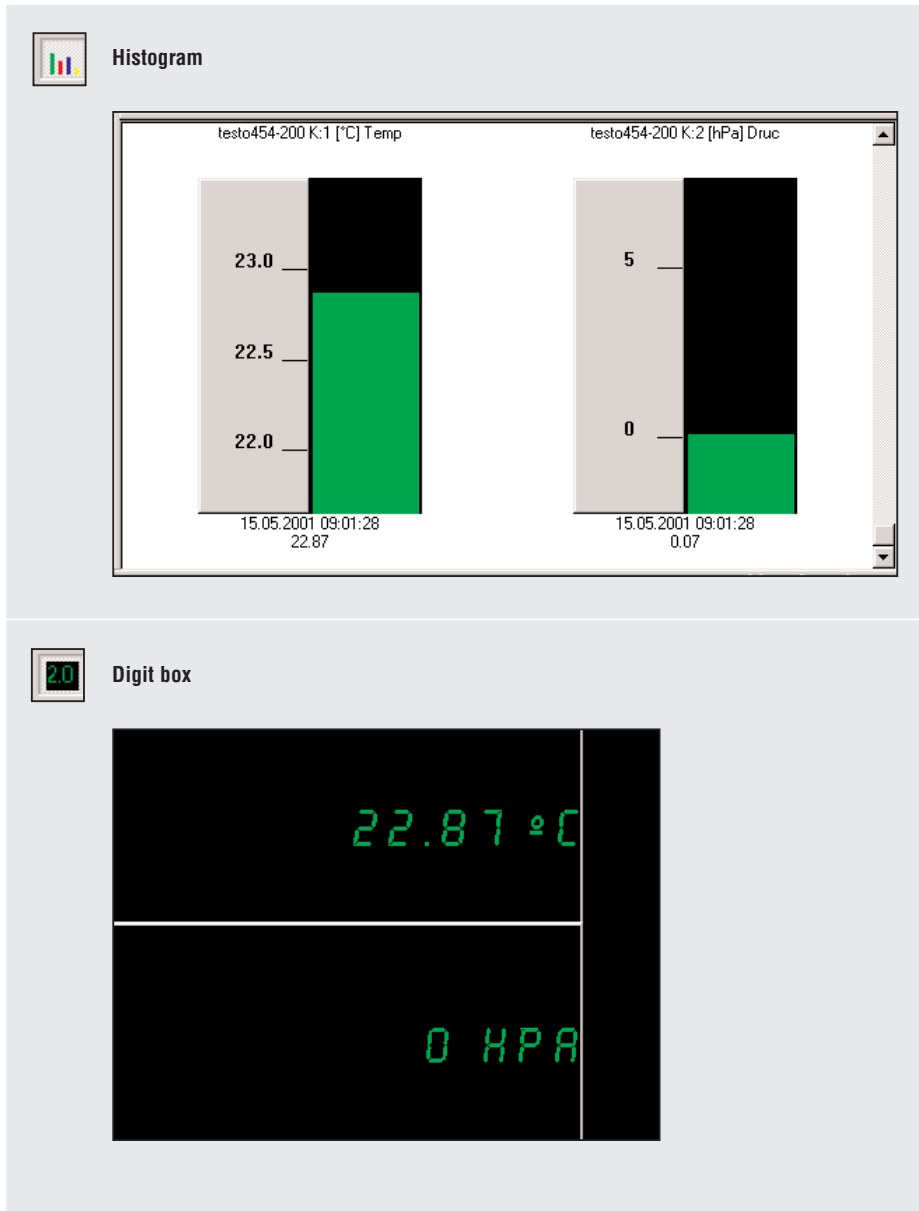

1. Description of the system components

1.8 Comsoft 454/350 1.8.4 Example 1

1.8.4.1 Demo file without instrument

Load the "D1" file from the "Sample files" folder and integrate it into the display diagram using the toolbar.

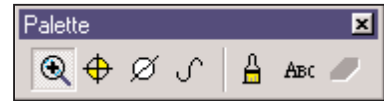

Zoom

Zooms sections

The limits for the area to be shown are set by drawing a rectangle in the diagram window (keep left mouse button pressed inside window). This function can also be carried out during an online measurement. The selected section always shows the current value.

The diagram is returned to its normal size by clicking on "Actual size". All of the section zooms are then undone.



"Crosshair"

Select a measurement curve to demonstrate a crosshair, which follows the curve. The reading number, date, time and reading are also shown in a window.



'Mark section'

Selective statistics.

You can determine the section in diagrams which is to be calculated or saved:



Click on the left of a curve to determine the section to be calculated; you can move the section limits using the left mouse button and the complete window using the right mouse button.

1.8.4.1 Demo file without instrument

“Compensating curve”

Compensating curves help to better assess large amounts of data; “runaways” are suppressed and the actual curve is imitated using a theoretical, mathematical function.



Select a measurement curve to show a compensating curve or to switch it off. The degree of the curve is determined at between 0 to 7 in the context menu for the curve (right mouse button). Degree 0 corresponds to a pure mean calculation, 1 degree describes the linear trend, a higher degree helps curves with several minimum and maximum values.

By contrast, if “Mark measurement points” is selected, the measurement points along the curve are marked. It is only at these points that the value shown corresponds exactly to the measured value. The curve between the points comes about through interpolation. If there is a measurement, the measurement points are interpolated linearly - are connected by straight lines. The curve can be smoothed if the measurement is stopped.

Smoothing in this case means that the measurement points are connected by an interpolating curve. This curve goes through all of the measurement points. It is, therefore, not a compensating curve. Only the space between two points is filled by a curve, or a type of spline.

Notes:

- The section is a time section. If you have determined a section for a measurement protocol, all of the calculations apply to this section. Remove the section limits if you wish to have the whole data sequence calculated.
- Section limits and mean calculation. Select a measurement curve to determine the time range to which the following calculations and data saving, if required, are limited. Section limits, the minimum and maximum of the limited value curve and the arithmetic mean are all shown in the status bar.

1.8.4.1 Demo file without instrument

If you encounter problems when clicking on a section of the curve, you have probably clicked on the section of the curve which is particularly steep. The capturing process functions better if you select a less steep section. If you are working with several which overlap it is better to work by zooming sections.

'Edit pattern'



Is used in diagrams and parametric graphs to set background and grid line colour and to change the line type in the grid.

Text



Used to add/delete **Text** to/from diagram.

Move text:

Use the left mouse button (drag-and-drop).

Change font type and colour:

Click with the right mouse button on the text.

Use the "Eraser" mouse function from the palette to delete the activated diagram text. The activated text now has a frame around it.



'Display status info'

Provides detailed error description of invalid readings.



1. Description of the system components

1.8 Comsoft 454/350 1.8.4 Example 1

1.8.4.1 Demo file without instrument

Start by clicking on the respective curve twice and first adapt the line width and pattern, smooth the curve and mark the measurement points, if required.

Define the required limit values in "Data sequence" and define how they are to be displayed in "Limit value display".

You can click away a curve or reactivate a curve by clicking twice in the diagram section.

Using the right mouse button in the diagram section, you will find modification possibilities for background and grid lines in pattern.

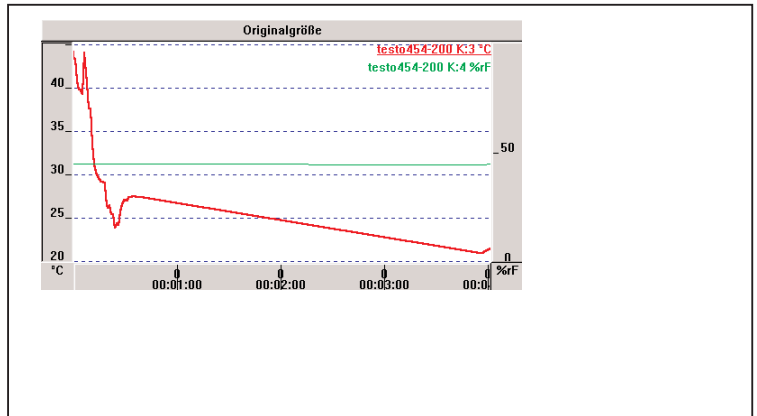

Edit the time axis:

You can define the resolution, start and finish of the view window by clicking twice on the time axis.

- "Relative timing" sets the starting time at 00:00; the time then starts relative to this start mark.
- "Width" defines a fixed frame which can be moved over the time axis.
- "Position" defines a fixed section.

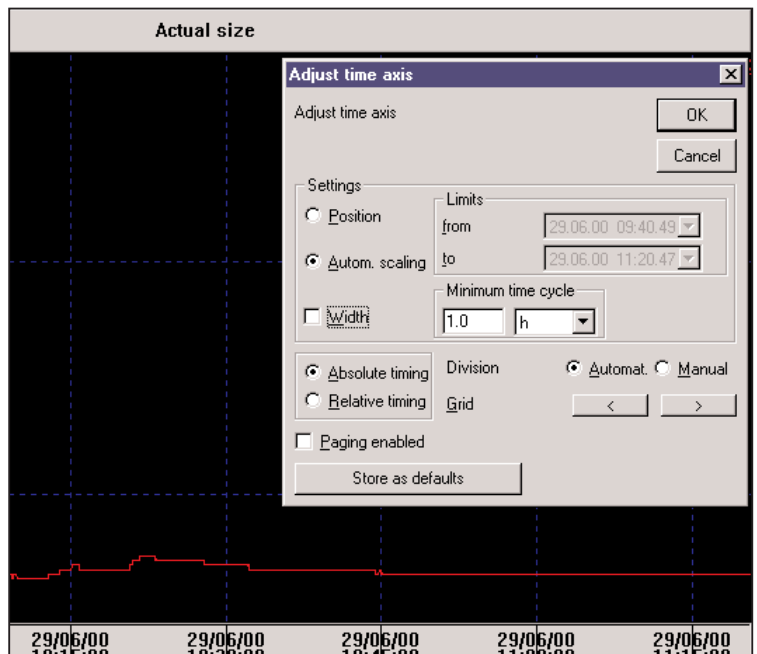

Optimise the value range/y axis:

For an improved overview, it is better to scale the range of values for the respective curve. Enter the menu by clicking on the right of the y axis. The grid can be set via the arrow buttons or can be entered manually by clicking "Manual".

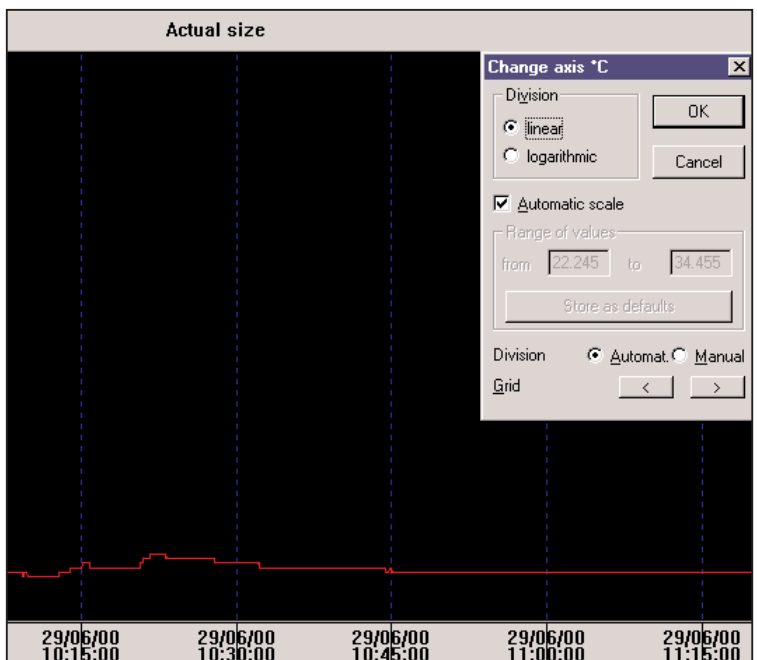

1. Description of the system components

1.8 Comsoft 454/350
1.8.5 Example 2

1.8.5.1 Control Unit and humidity probe, logging measurement sequence

Logging air humidity and temperature values using a Control Unit and connected humidity probe.

For details on application limits, initial operation, error messages etc. please see the instrument instruction manual.

Initial operation/connecting hardware

- Connect humidity probe to instrument
- Connect instrument to PC via cable to RS-232 port
- Switch on instrument
- Load software
- Select "Instrument", "New device", "testo 350/454".
- Follow the assistant until the instrument symbol appears in the archive.

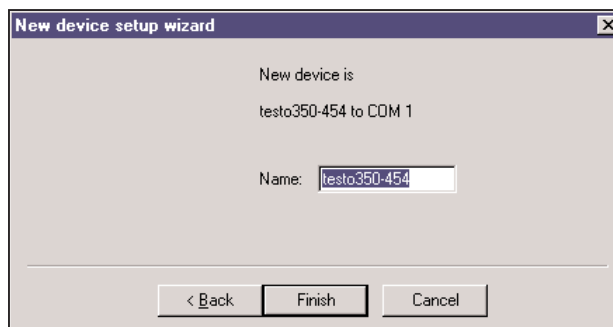
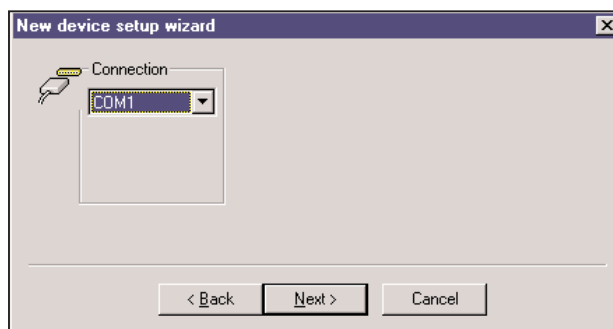
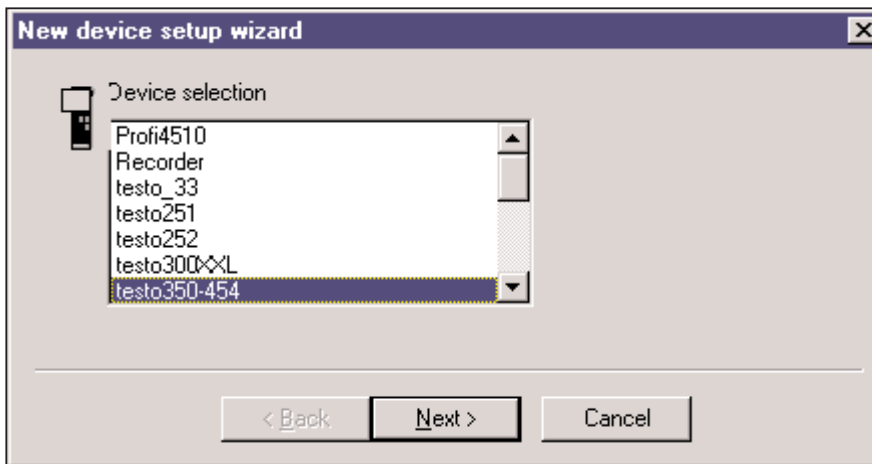
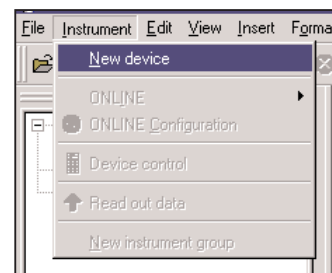

1. Description of the system components

1.8 Comsoft 454/350

1.8.5 Example 2

1.8.5.1 Control Unit and humidity probe, logging measurement sequence

Selecting instrument/Device control

Click, activate context menu via the right mouse button, select "Device control", then "Delete memory" in "Configuration Instrument".

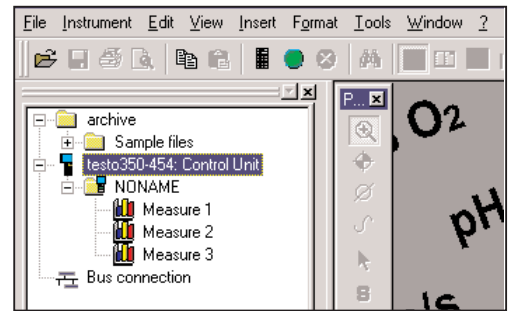

Programming instrument

- "Measurement program" in register
- Manual
- Number of values: 200
- Measuring rate: 2 s
- "Apply", "Start" and cover probe tip with hand (produces interesting curve)
- Click "OK" and close instrument via context menu.

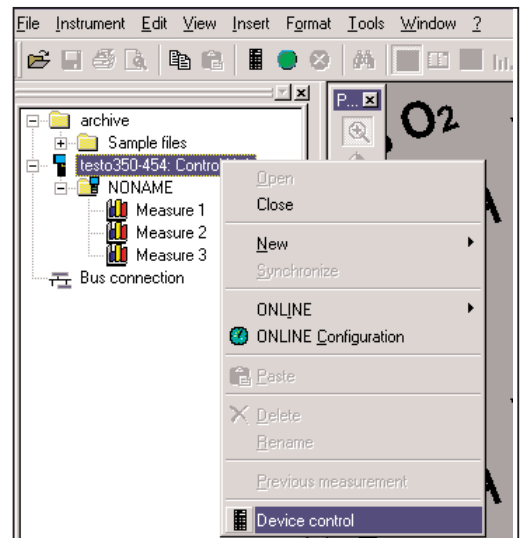
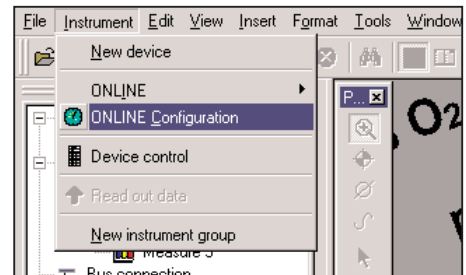

1. Description of the system components

1.8 Comsoft 454/350
1.8.5 Example 2

1.8.5.2 Control Unit and humidity probe, analysing measurement sequence

Reading out instrument

- Open instrument via the context menu.
- Drag the protocol by mouse into the work area, which directly displays the table view
- Drag the location by mouse into the work area, which activates the read-out assistant with automatic search function in archive.
- Right mouse button on button at top left of table gives additional information on protocol or point of measurement; comments can be edited.



Context menu in the table

- Content: deactivates columns (insert/remove columns)
- For example, a new dew point column can be generated via “Insert, Formula”.

View as diagram click on curve

- Smooth and mark measuring points
- Define line width and style

Data sequence

- Upper and lower limit values should have different colours

Click on axis

- Set division
- Select ranges

Context menu in diagrams

- Insert text
- Label header for printout

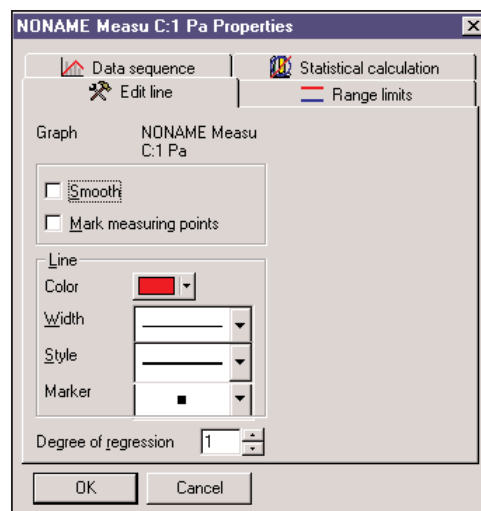

1.8.5.3 Control Unit and humidity probe, exporting saved data

Editing readings

Managing reference data

In diagrams, it is possible to save the data just measured with the curve of a previous measurement (reference data). To do this, the reference protocol has to be read from the file and assigned* to a diagram. Depending on the length of the reference protocol (relative time scales apply in this case...), this reference data is visible in addition to the data from the current measurement, provided it is also shown in the diagram.

*) determines which view is assigned which curve. Values can be added to or exchanged in a diagram, table or scale.

Depending on the quality of the view

- 8 measurement sequences from different protocols can be shown in diagrams,
- All of the measurement sequences of a protocol are shown in tables.

Exporting to other programs for further editing

Open the program parallel to Comsoft 3 to transmit data e.g. in MS EXCEL®. Drag data from the instrument via drag-and-drop over the EXCEL® button in the footnote to the EXCEL® worksheet.

If a location is dragged to the button, all of the connected protocols are transmitted to an EXCEL worksheet.

Data can also be transmitted to other programs which support this function.

You can also use Copy/Paste as an alternative to drag-and-drop.

1. Description of the system components

1.8 Comsoft 454/350 1.8.6 Example 3

1.8.6.1 Control Unit and humidity probe, direct display of readings

Measuring

Measurement is conducted via “Instrument/ONLINE/Start and/or Stop”. The measuring rate can be set in advance via “Instrument/ONLINE Configuration”.

The number of data which can be saved is limited; the maximum possible duration of the measurement is shown with the selected setting.

ONLINE data transmission from the measuring instrument to the measurement protocol can be started, frozen or continued. The various buttons can be accessed depending on the program mode.

- Start: Starts a new measurement.
A new measurement protocol is set up.
- Stop: Stops a measurement.

Displaying readings

Readings can be shown in diagrams or tables. Several of these views can be shown simultaneously in windows. The values shown are updated constantly during measurements.

Click on the respective symbol in the toolbar.

Saving measurement data

Measurement protocols can be copied as a file on the hard disc of your computer for editing at a later stage, printing or to be opened.

Last measurement

If data is lost, you can use this method to restore data from the last measurement. The data comes from a backup file, which is only updated every 30 seconds. In some cases, the last measurement data could be missing.

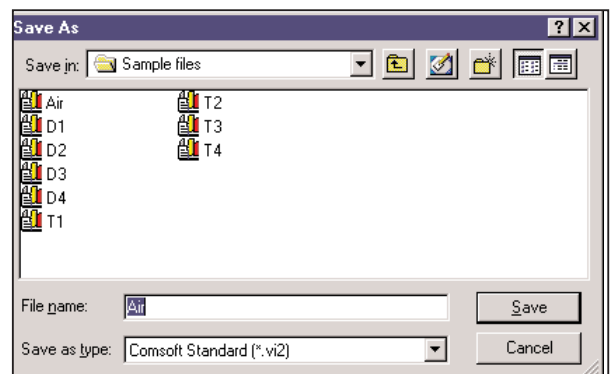
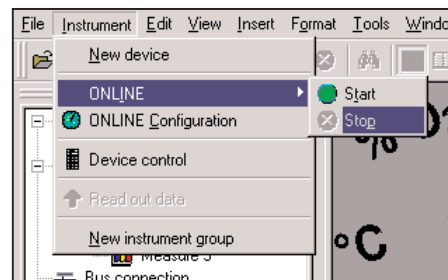
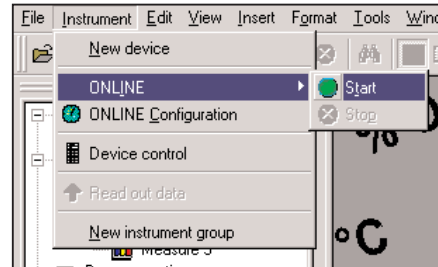

1. Description of the system components

1.8 Comsoft 454/350 1.8.7 Error messages

Instrument is not responding:

- Check if instrument is switched on.
- Check connection cable.

This message appears if the PC program cannot communicate with the connected measuring instrument or if the measuring instrument does not respond.

- Is the instrument switched on?
- Does the instrument have sufficient power?
- Is the connection cable connected?
- Is it the correct connection cable?
- Correct COM Port connection?

Your instrument has indicated that probes are not working.

Measuring impossible.

- You are trying to get an online measurement from an instrument to which a probe is not connected.
- Connect the corresponding probes.
- Not all of the input variables for the function “...” are contained in the measurement protocol. You have selected a pre-defined function which needs more or other parameters than those included in the measurement protocol e.g. you want to calculate the dew point, but only the temperature is available, which means that the humidity parameter is missing.

The folder is not empty. Not possible to delete:

The program does not allow you to simply delete full folders. First delete the data or locations in the folder in order to be able to delete the empty folders or delete the folder in Windows Explorer.

Not possible to delete protocol: Close and delete the file.

- You want to delete a file which is still open for editing. Open files cannot be deleted.
- Close the file.

Invalid name:

! , ? , * , : , \ cannot be used in location and folder names.

Rename the location/folder and do not use these characters.

An instrument setting with this name is already available: Please select a new name.

Different names should be used when setting up new instruments. The same names should not be used for different instruments.

The time ranges overlap.

You are trying to connect protocols using invalid data. Overlapping time ranges cannot always be merged in a common protocol.

1. Description of the system components

1.8 Comsoft 454/350 1.8.8 Details/Backgrounds

1.8.8.1 Display ranges

Testo Comfort software has all the functions needed to control and configure Testo measuring instruments, to transmit data to your PC and to edit it. This chapter describes all the commands necessary.

Testo Comfort Software is divided into two main parts: the archive and the work area.

Archive

Your measuring instruments and measurement data are managed in this area.

All of the measuring instruments are inactive when the program starts. If you want to activate a measuring instrument which is connected, double-click on the symbol for the measuring instrument. Connection to the measuring instrument is set up and the symbol for the instrument changes.

Alternatively, you can click on the symbol for the instrument with the right mouse button and you will then receive a context sensitive menu from which to select. Select "Open" to activate the required measuring instrument. The measuring instrument has to be connected and switched to the correct port.

Locations and directories can be set up in the archive, which resembles the Windows Explorer® interface. You can set up, copy, delete etc. sub-directories by clicking the right mouse button on a directory or a location.

If there are saved measurements in the measuring instrument and these are shown below the measuring instrument, you can drag and drop the data from the measuring instrument to a folder in the archive. You can copy several items by keeping the control button pressed.

You can also copy the data (from the measuring instrument or archive) into the work area for display purposes. Mark the required data with the mouse and drag it into the work area.

A folder is represented by the symbol for .

A location is represented by the symbol for .

A measurement protocol is represented by the symbol for .

The measuring instruments which follow are then represented by different symbols.

The symbol changes if an instrument has been opened successfully.

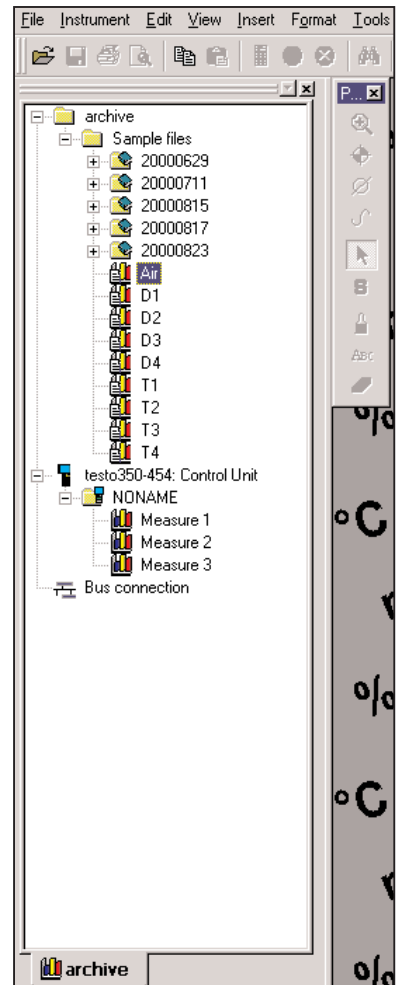

1. Description of the system components

1.8 Comsoft 454/350 1.8.8 Details/Backgrounds

1.8.8.1 Display ranges

Work area

Your data is shown in this area.

If you copy your data from the archive to the work area, the data will be shown. You can decide which type of display to take.

It is possible to change the view if so required. Simply click on the corresponding symbol in the toolbar.

Once you have displayed a measurement in the work area, you can call up a menu in which further settings can be carried out by clicking with the right mouse button in the display:

The exact appearance of this menu depends on the view selected.

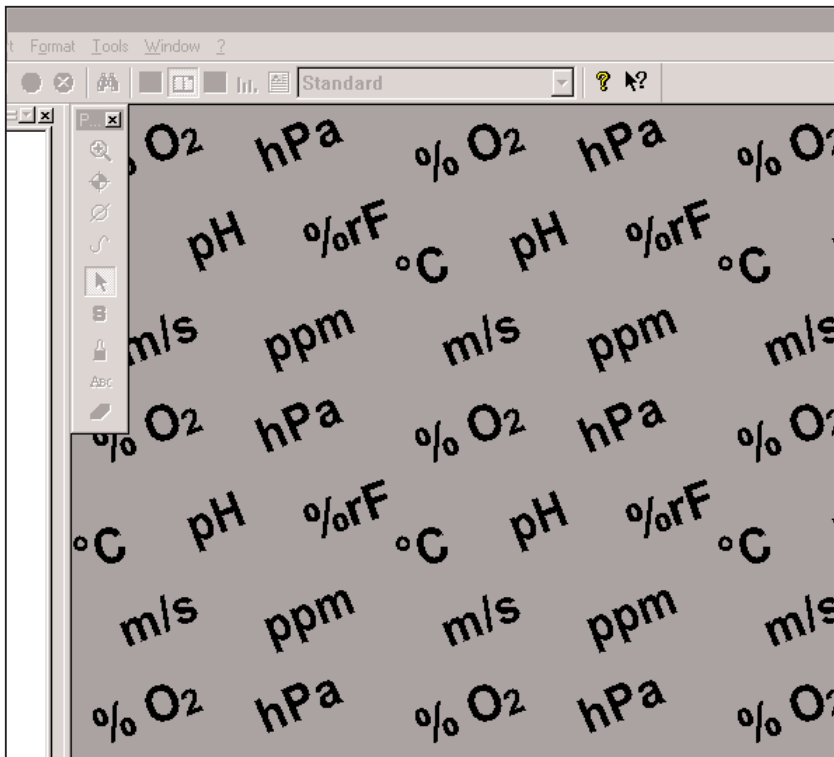

1. Description of the system components

1.8 Comsoft 454/350 1.8.8 Details/Backgrounds

1.8.8.2 Main menu item: 'File'

File/Open

The data of a measurement protocol can be read in. For example, you can save the current measurement as reference data or display later, as often as required, for checking purposes.

Measurement data files have the file name extension "prn" or "vi2". Only files which were set up using this version, a previous version, or the Testo PC adapter software are accepted! "wks" files can also be read in.

Measurement protocols contain

1. Per data block:

A protocol header: The units of the measured parameters and additional information from the measuring instrument are located here, depending on the structure of the readings.

2. Many data items within a data block consisting of:

- Time stamps: Date and time of respective measurement
- Readings: From all the connected channels

File/Save

Measurement protocol data is saved as the name (and type) displayed in the top line, using this function. If it is a newly created data record, which does not yet possess a name, it is necessary to select one. In this case, the type of protocol is "vi2" and is marked by the symbol .

File/Save As...

Measurement protocol data is saved in a file on the hard disc of your computer. Data is saved in the RAM of your computer during the measurement. This is deleted once you exit the program. If you wish to create protocols with stable values or you wish to analyse, print the data etc. with this or other programs at a later stage, you should save the data in a file.

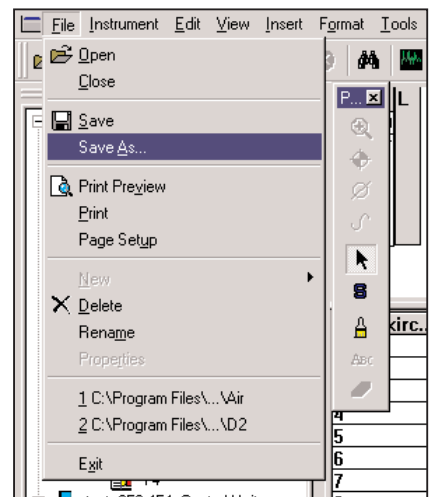
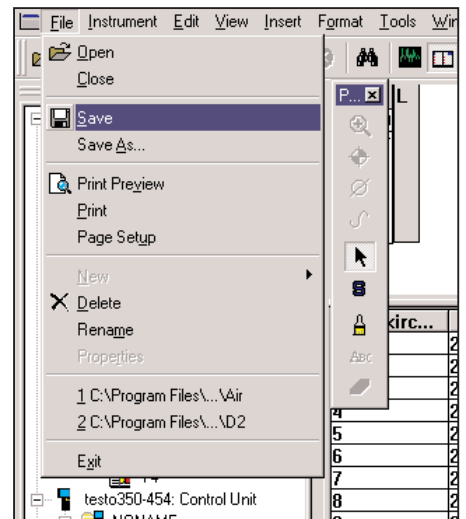
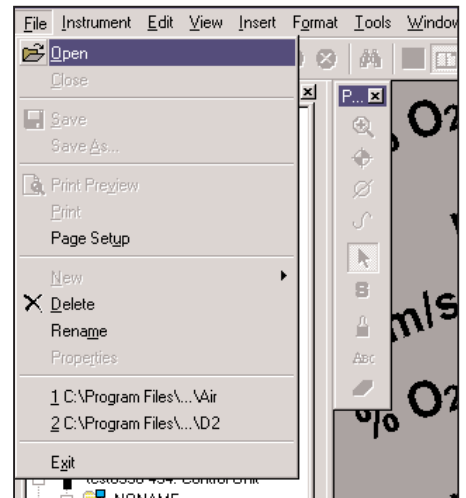

1. Description of the system components

1.8 Comsoft 454/350 1.8.8 Details/Backgrounds

1.8.8.2 Main menu item: 'File'

Print Preview

The view will be printed exactly as it appears on the screen.

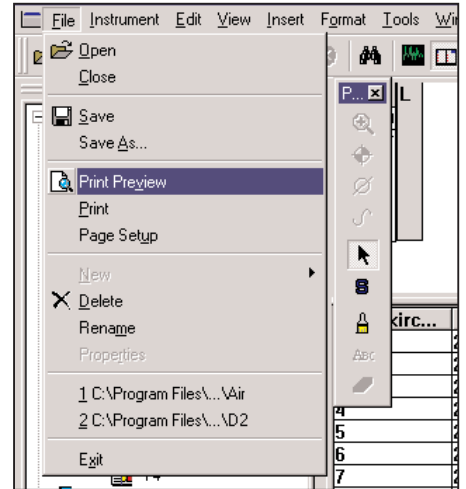

Printing

Readings can be printed in diagram or table form. A sheet is printed containing the following elements:

1. Protocol header with title (pre-set with file or instrument names), date, start or finishing time of a measurement (tables only), channel and reading number (tables only), current page number, "Conditions" line and additional comment lines.

2. Readings in diagram or table form

When printed, the protocol header contains information on the complete measurement protocol.

It is recommended to use portrait format when printing tables and landscape format when printing diagrams.

Set the format with "Page Setup".

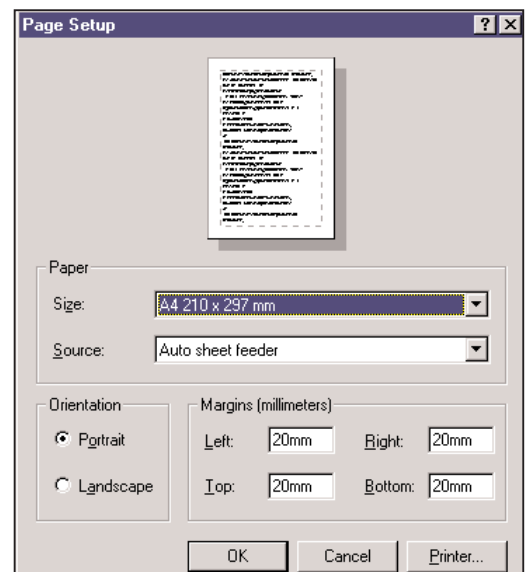
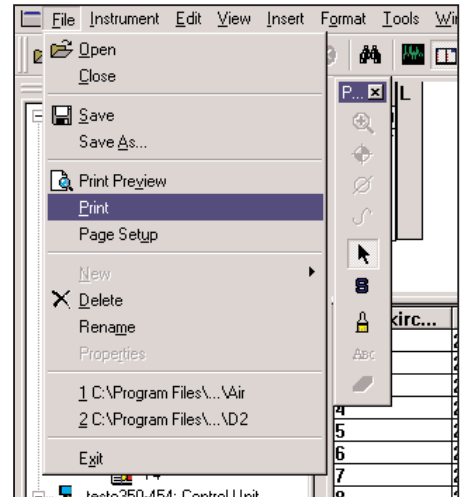

1. Description of the system components

1.8 Comsoft 454/350 1.8.8 Details/Backgrounds

1.8.8.2 Main menu item: 'File'

Example diagram print-out

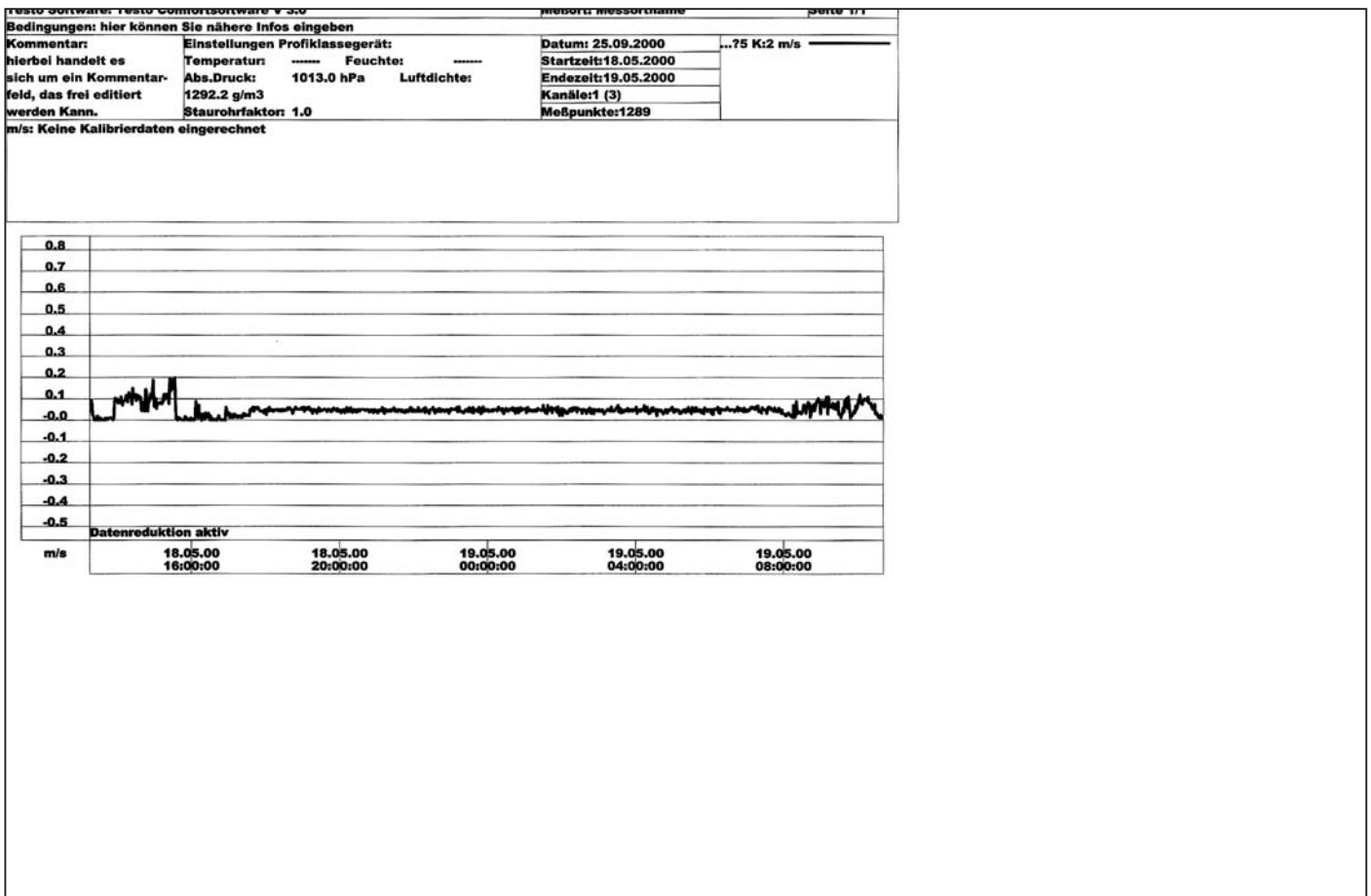

1. Description of the system components

1.8 Comsoft 454/350 1.8.8 Details/Backgrounds

1.8.8.2 Main menu item: 'File'

Opening the files last used

The files last used can be opened here. The required file is opened by clicking on the respective file name. However, if you have already deleted or moved this file to another location, you will, of course, not be able to open it and you will receive an error message.

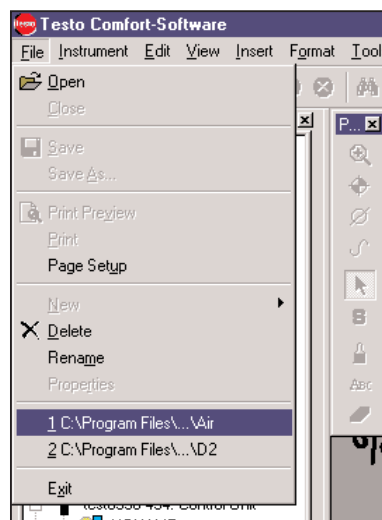

Setting up a new location

You can assign as many locations as required within an archive, which can then be managed and structured in one of the tree structures familiar from Windows Explorer®. The location or also the location name is used to assign measurement data (reading, unit, time) a name relevant to a specific location or other attributes.

Preparing the measurement

It is recommended to set up a fixed structure in the archive for comprehensive measurements at many different locations e.g. when measuring the climate data of an entire house.

These locations can then be transmitted to the testo 400 instrument with additional information such as required value, channel dimensions etc., if so required.

The location names are in the display on site. Selection is possible via "up/down, OK" or barcode pen. Saved data is then coupled with a location name until it is filed in the PC archive.

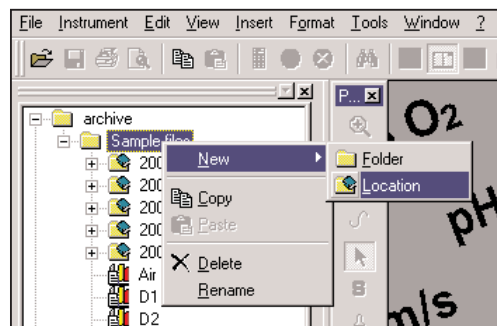

1. Description of the system components

1.8 Comsoft 454/350 1.8.8 Details/Backgrounds

1.8.8.3 Main menu item: 'Instrument'

New device

The assistant for setting up the instrument supports you when adding additional measuring instruments to your configuration.

You will get to the next page via "Next" and to the previous page via "Back".

The instrument which is to be set up should be connected to the computer and switched on, since the New device setup wizard checks the connection to the measuring instrument once setup is complete.

1. A list of instruments appears for you to select. Select the instrument which you have just connected.
2. The next step is to select the interface to which the instrument is connected. It is only when you have selected an interface that you can leave this page.
3. You can now assign your newly setup instrument a name which should appear in the Comsoft software. Make sure that you choose a name which is not already being used for another instrument. The name of the measuring instrument is shown as standard.
4. An attempt is made to set up a connection to the instrument.

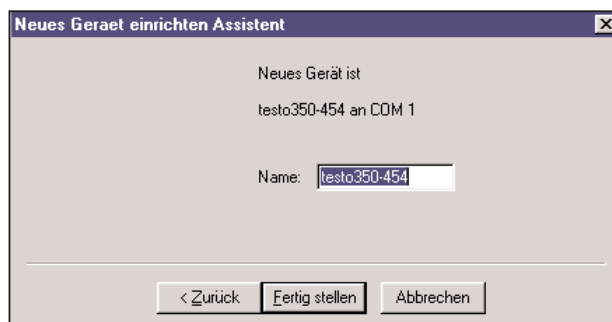
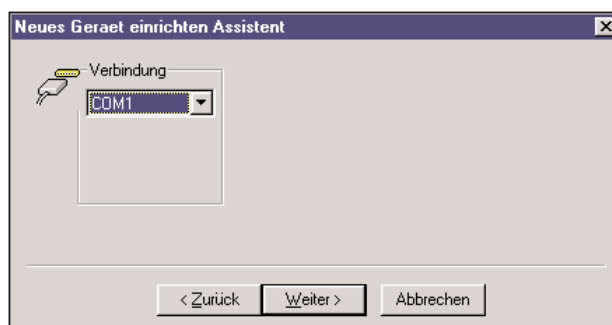
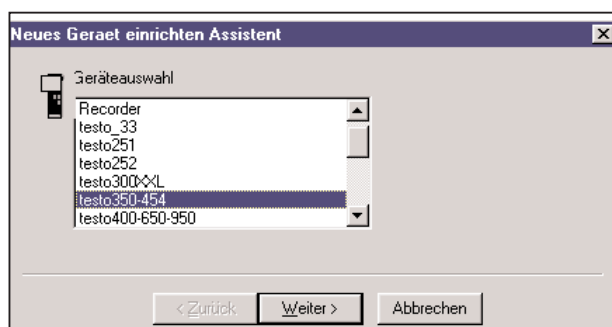

1. Description of the system components

1.8 Comsoft 454/350 1.8.8 Details/Backgrounds

1.8.8.3 Main menu item: 'Instrument'

Device control

This menu item is used to call up the configuration page of the selected instrument. These are adapted to the corresponding instruments and make available the respective setting options on offer.

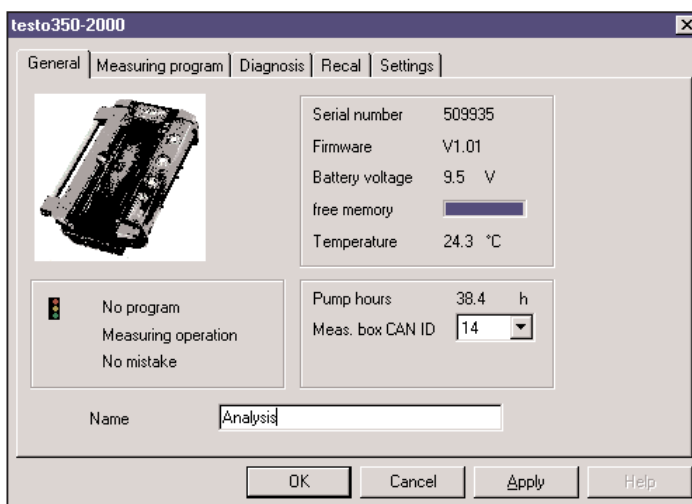
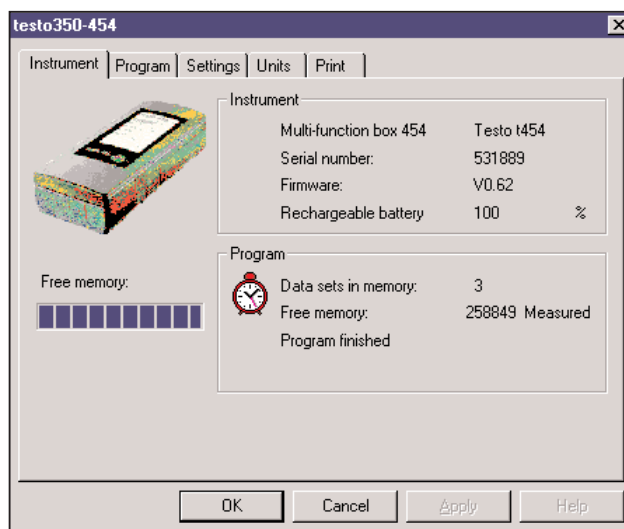
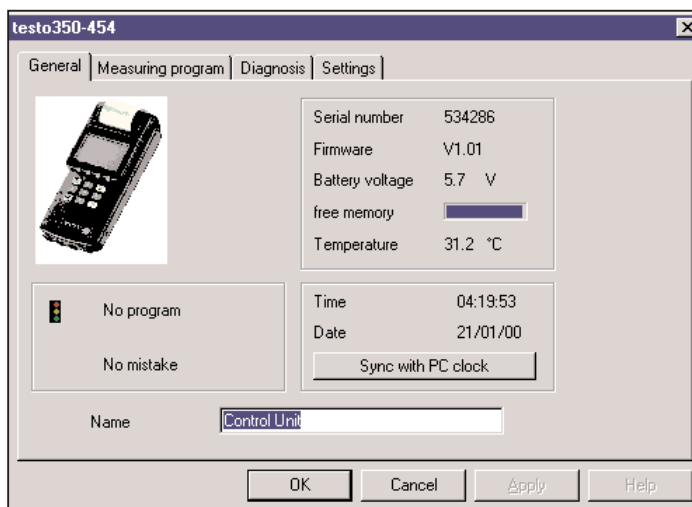

1. Description of the system components

1.8 Comsoft 454/350 1.8.8 Details/Backgrounds

1.8.8.3 Main menu item: 'Instrument'

Online

One of the following two elements appears in this menu item once you have opened an instrument:

Start

Start the online measurement with this menu item/icon. Data is shown automatically in the work area.

Stop

You can hold the current online measurement with this menu item/icon. You can now also save the protocol from the work area on your hard disc.

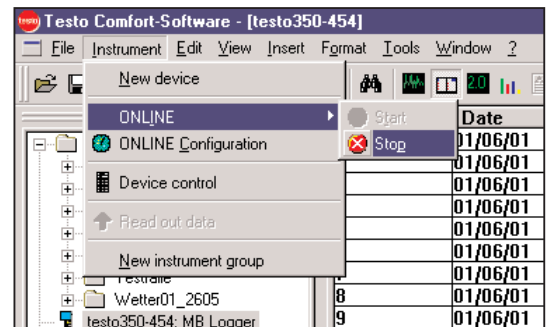
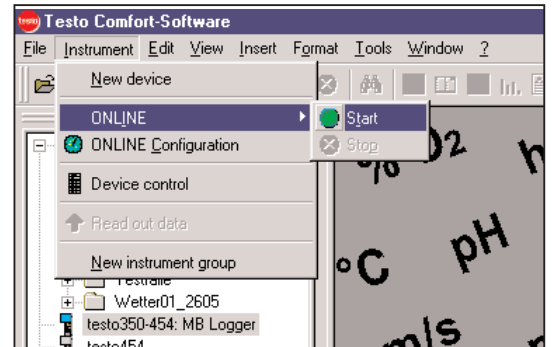

ONLINE Configuration

The measuring rate for online measurement is set here. The maximum number of measurements is calculated from this measuring rate. The minimum adjustable measuring rate depends on the instrument and is checked accordingly.

The data is buffered at regular intervals in a temporary file on the hard disc.

Measurement finishes automatically once the maximum measurement time has been reached.

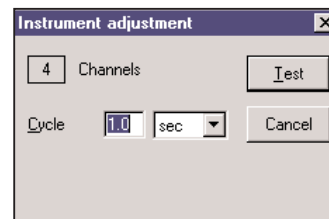

1. Description of the system components

1.8 Comsoft 454/350 1.8.8 Details/Backgrounds

1.8.8.4 Main menu item: 'Edit'

Undo

Undoing the last action

Use this menu item to undo the last action.

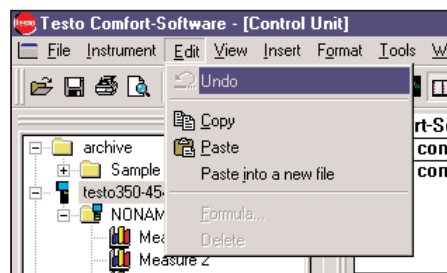

Copy

Diagrams, tables or sections of the tables can be copied into the WINDOWS clipboard which are then available in other application programs with the PASTE menu item. In this way, you can get a graph or values from another table into another program. You can also copy the data within Comfort software in the same way.

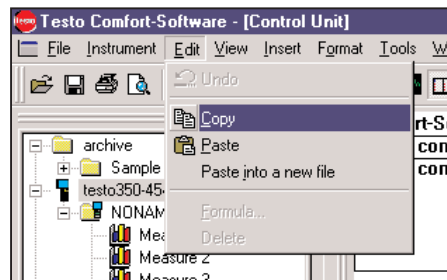

Note:

To prepare the picture of a graph for subsequent printing using a different program, please first select the line and background colour or patterns/styles which can be printed.

Paste

Measurement sequences, locations or directories which were copied from the archive to the clipboard can be pasted at the desired location.

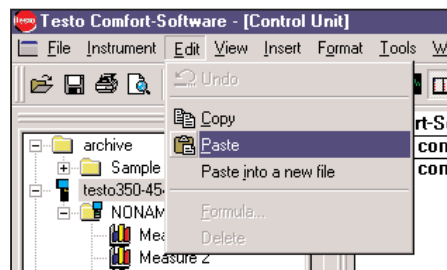

Paste into a new file

The files copied to the WINDOWS® clipboard are pasted into a newly opened file.

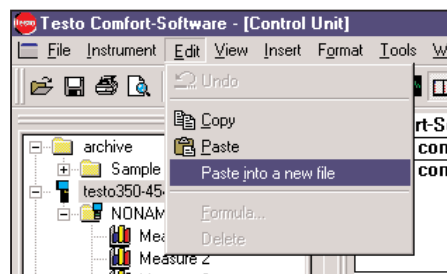

1. Description of the system components

1.8 Comsoft 454/350 1.8.8 Details/Backgrounds

1.8.8.4 Main menu item: 'Edit'

Formula

A complete pre-defined formula can be edited or redefined using this command.

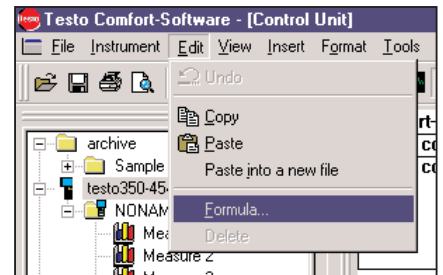

Delete

Deletes all the formulated functions and contents for this measurement data.

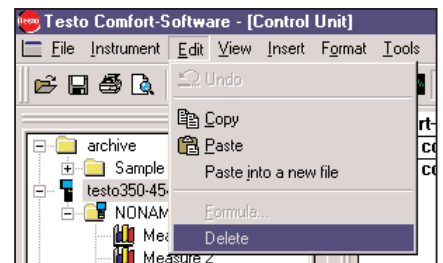

1. Description of the system components

1.8 Comsoft 454/350 1.8.8 Details/Backgrounds

1.8.8.5 Main menu item: 'View'

All of the functions pertaining to screen layout and graphic design are located here. The graphical presentation of readings is the main task of this program. Readings can be shown in diagrams and tables, for example. Several such views can be shown simultaneously in a window. The values shown are constantly updated during measurement.

The following is a list of the functions included in this menu.

Toolbar

Switches functions which appear in "Tools, Customize", on or off, as required. In this way, you have more space on your screen to show data.

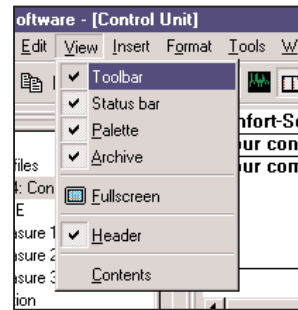

Palette

The palette, which is used to edit diagrams, is switched on or off as required.

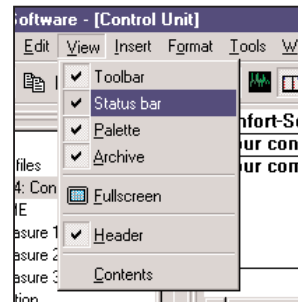

Status bar

The bottom window line is switched on or off. Information, status displays and notes normally appear at this point.

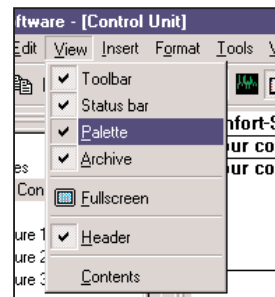

1. Description of the system components

1.8 Comsoft 454/350 1.8.8 Details/Backgrounds

1.8.8.5 Main menu item: "View"

Archive

The archive and registered instruments are displayed or not displayed.

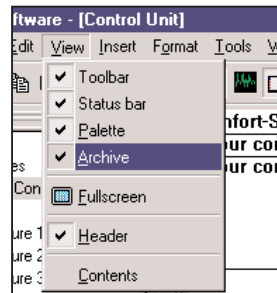

Fullscreen

Enlarges the presentation area to screen size.

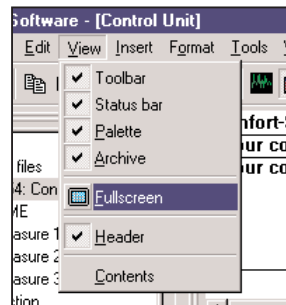

Header

Used to fill header of current diagram/table. The appearance of the protocol header depends on the chosen layout.

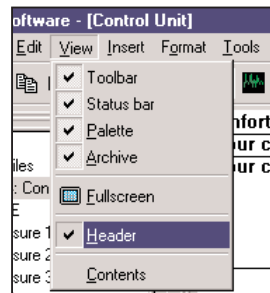

Contents

Individual channels can be activated or deactivated in the protocol shown.

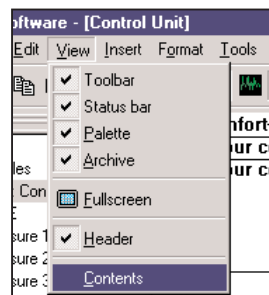

1. Description of the system components

1.8 Comsoft 454/350 1.8.8 Details/Backgrounds

1.8.8.6 Main menu item: 'Insert'

Text

Text can be added to diagrams.

The text entered in the text box can be moved (hold right mouse button and drag) to any point on the diagram area. If you double-click on the right mouse button when the text box is activated, the font attributes can be changed.

The "Eraser" palette symbol deletes a selected text box from the screen.

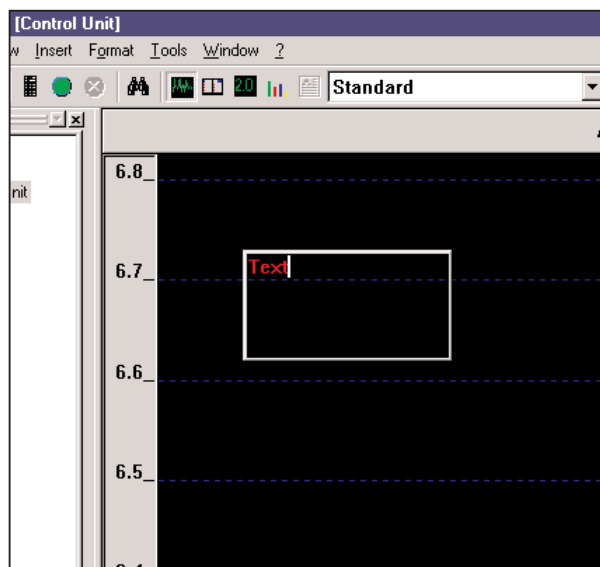

Function

If there are several channels in a measurement protocol e.g. temperature, humidity, they can be offset. The result is a new value sequence which can be displayed and edited.

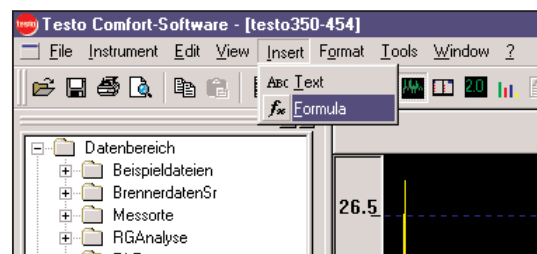

Formulae

You can subject the readings to individual calculation by inputting formulae.

For example, the formula "(K<Index>-32)*5/9" converts a temperature value with "Degrees Fahrenheit" to "Degrees Celsius". Formulae can be applied to the data sequences of individual protocols.

Notes

The decimal point is as follows: 10.50. Values on a parameter list are separated by a comma e.g.: td (K2,K1).

Syntax

Permitted digits/symbol sequence for a formula and an arithmetical printout.

Symbols

Numerical constants e.g.: 3.14

Channel references: K<Index> e.g.: K1

Mathematical operators: +, -, *, /, ^ for exponents

Mathematical functions: sqrt(<Printout>)

Trigonometric functions: sin(<Printout>), cos(<Printout>)

Gradient operator "e.g.: K2" to determine the timed derivation of the parameter measured in channel 2

Case differentiation: if <Condition> then <Printout> else <Printout>

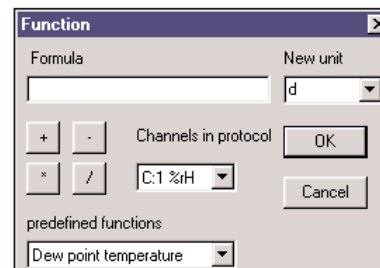

1. Description of the system components

1.8 Comsoft 454/350 1.8.8 Details/Backgrounds

1.8.8.7 Main menu item: 'Format'

This menu item contains the following entries:

Font

You can set the fonts to be used here. This font is then used for protocols and to label diagrams.

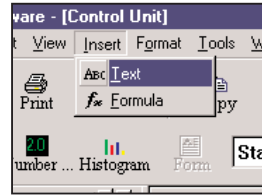

Pattern

Used to set units, common axes, background colour and limit value colours.



1. Description of the system components

1.8 Comsoft 454/350 1.8.8 Details/Backgrounds

1.8.8.8 Main menu item: "Tools"

Settings

The Settings menu contains the following elements:

- Diagrams:
 - Curves: Standard allocation of colour, width and style to the eight curves shown in a diagram. In diagrams and parametric graphs: sets background and grid colour, line type in grid.
- Colour code: Tick this box to enable the allocation of the diagram line and histogram bar to the parameter. The variable axis in diagrams is labelled with a colour associated with a parameter. Histogram bars are coloured individually within the limit values.
- Common axes: Tick this box to show more than three different parameters together in one diagram. Use UP/DOWN to select the parameters which are to be assigned to a common variable axis.

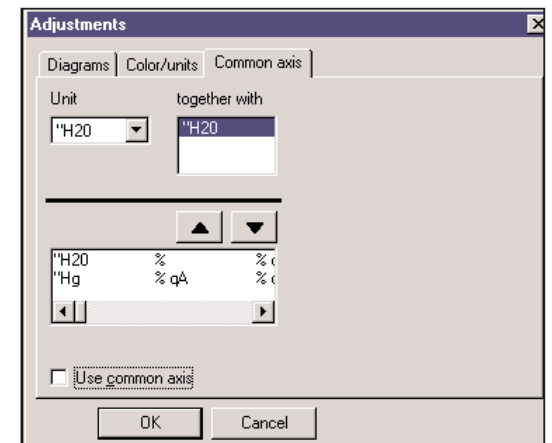
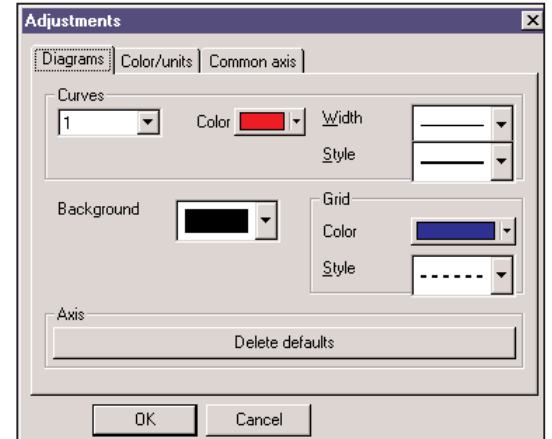
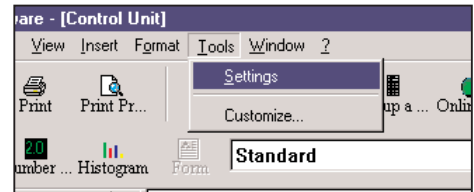

1. Description of the system components

1.8 Comsoft 454/350 1.8.8 Details/Backgrounds

1.8.8.8 Main menu item: "Tools"

Customizing

It is possible to influence the appearance of the Comfort software with this menu item. You can set the following:

- Toolbar (displayed/hidden)
- Large or small symbols
- Which symbols are to appear in the toolbar

Open the register to change the toolbar shown and move the corresponding symbol to the required location. Click on the bottom of the symbol for more information.

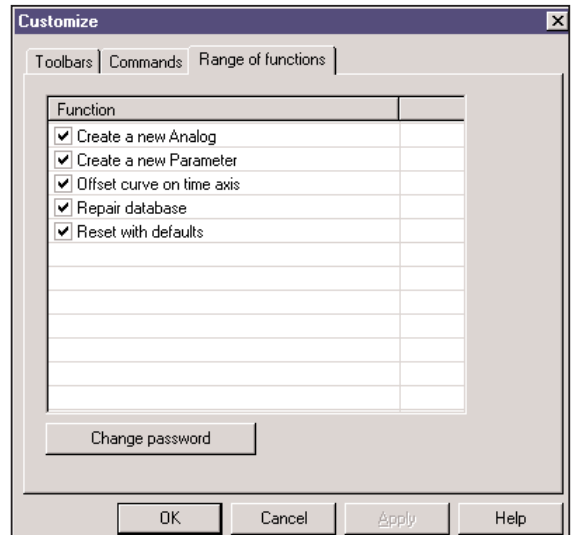
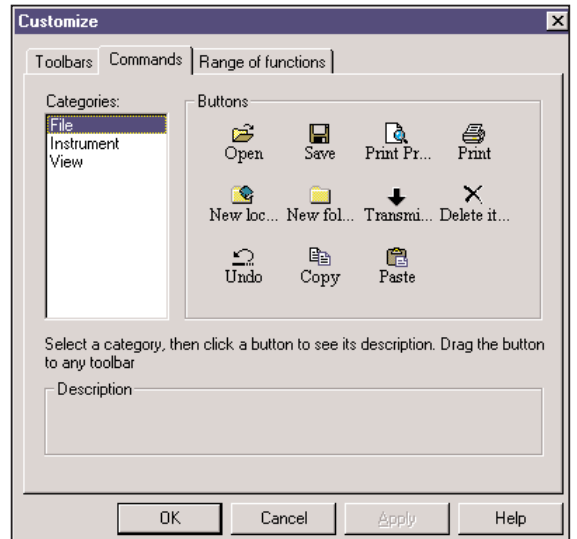
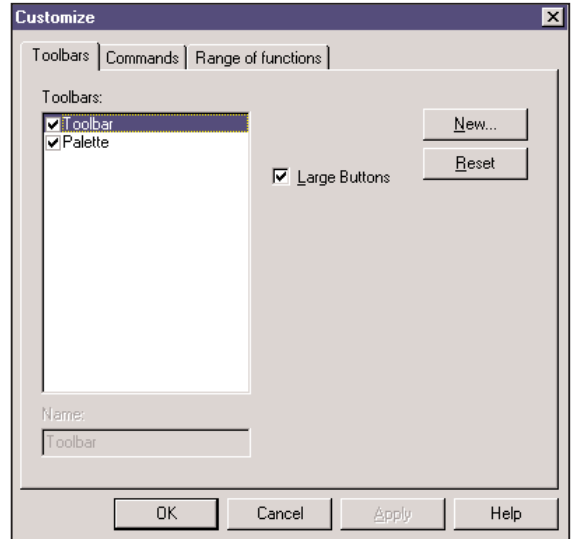
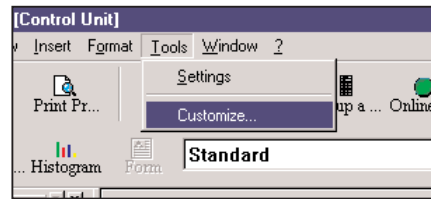

1. Description of the system components

1.8 Comsoft 454/350 1.8.8 Details/Backgrounds

1.8.8.9 Main menu item: 'Window'

Window

The following sub-menu items can be selected:

Tiled

Tiled horizontally

Cascading

The names of all the open measurement protocols are shown, which are ticked when activated (foreground).

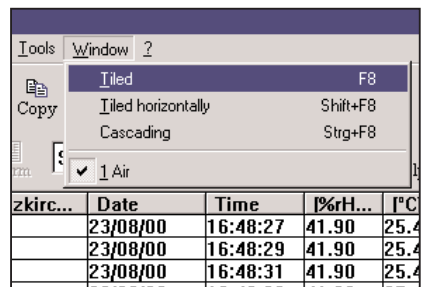

1.9 Testo databus



1. Description of the system components

1.9 Testo databus

The Testo databus system is used to transfer data and function commands. The individual components are also supplied with power through this bus system.

The connection can be made in 2 ways:

- Plugging on the components directly (Control Unit, data logger etc.)
- Connection of the components with a databus cable.

Max. length of the databus cable:

- Max. 50 m with power supply to the components through the databus
- Several hundred metres without power supply to the components through the databus.

Caution!

- Please use Testo databus cables only.
- When routing the cables, ensure that they are not laid beside three-phase power or similar cables. This could impair the function!
- Ideally, connect the cables when the system is switched off. So-called "Hot-Plugging" is possible, although it may be necessary to switch the entire system off and on depending on the combination.
- Ensure that the individual components have different bus addresses. (BUS ID)

The bus address is set via **Service** --> **Bus address**.



Terminal plugs for the Testo databus

The data connection is linear in structure. The beginning of the line is the Control Unit or the Testo databus card.

The terminal plug must be used for the loggers at the last instrument on the databus. This ensures a defined electrical state.



1.10 System examples of testo 454 logger

1.10.1 Systems with control unit

- 1.10.1.1 Standard delivery of control unit
- 1.10.1.2 Power to control unit via Testo rechargeable battery pack/mains unit
- 1.10.1.3 Control unit and 1 logger
- 1.10.1.4 Control unit and 2 loggers
- 1.10.1.5 Control unit and 3 loggers
- 1.10.1.6 Control unit, logger and analog output box

1.10.2 Systems with the PCMCIA card

- 1.10.2.1 PCMCIA card and 1 logger
- 1.10.2.2 PCMCIA card and 2 loggers
- 1.10.2.3 PCMCIA card and 3 loggers
- 1.10.2.4 PCMCIA card, logger and analog output box

1. Description of the system components

1.10 System examples of testo 454 logger

1.10.1 Systems with control unit

1.10.1.1 Standard delivery of control unit

The control unit is supplied with 4 batteries and is fully functional with these batteries.

Components	Part no.
Control unit	0563 0353
Option:	
Touchscreen with pen	0440 0559
Software ComSoft 3	0554 0841

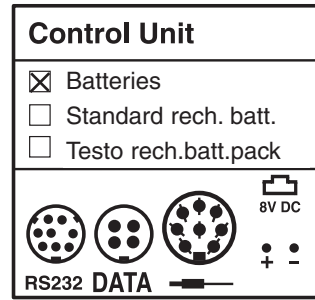

1.10.1.2 Power to control unit via Testo rechargeable battery pack/mains unit

The Testo rechargeable battery pack is recommended for the control unit.

The Testo rechargeable battery pack can be charged with mains unit connected in the control unit. Meanwhile, the control unit is switched off. If operating using mains, the rechargeable battery is recharged simultaneously during the measurement.

Components	Part no.
Control unit	0563 0353
Mains unit for control unit	0554 1084
Testo rechargeable battery pack	0515 0097
Option:	
Touchscreen with pen	0440 0559
Software ComSoft 3	0554 0841

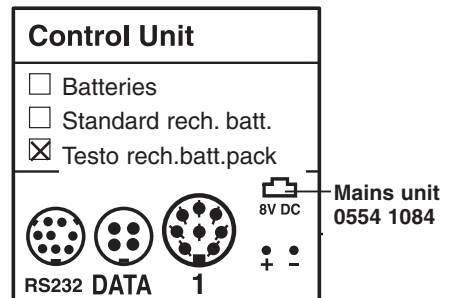
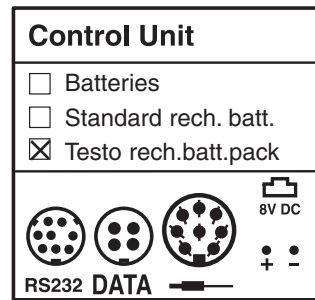

1.10.1.3 Control unit and 1 logger

Control unit and 1 logger connected

The control unit with a logger attached is a compact, portable hand-held instrument for applications in the field.

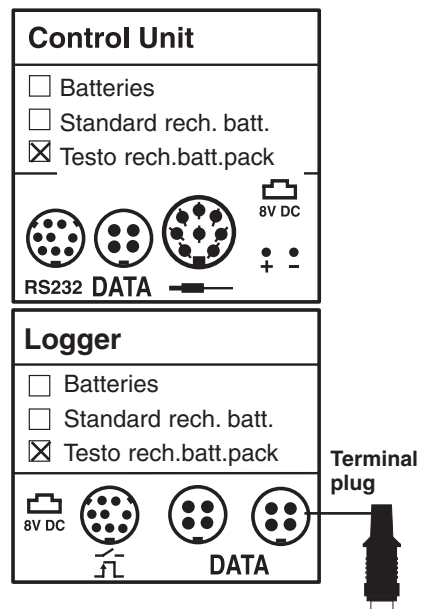

1. Description of system components

1.10 System examples of testo 454 logger

1.10.1 Systems with control unit

If the 0554.1084 mains unit is attached to the control unit, the Testo rechargeable battery pack in both the control unit and the logger are recharged. Recharging can be accelerated by attaching a mains unit (0554.1084) to the logger.

Components	Part no.
Control unit incl. terminal plug	0563 0353
Testo rechargeable pack	0515 0097
Mains unit for control unit 0554 1084	
Logger 0577 4540	
Testo rechargeable battery pack	0515 0097
Option:	
Touchscreen with pen	0440 0559
ComSoft 3 software	0554.0841

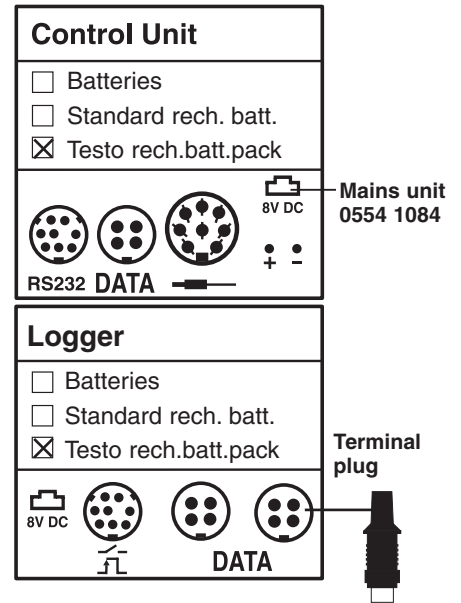

Control unit and 1 logger via Testo databus

When the logger and control unit are powered by the Testo rechargeable battery pack, the maximum databus length is 100 m.

The control unit switches bus communication off once the Testo rechargeable battery pack in the control unit is spent. Logger online operation is then no longer possible. Once the logger has an internal Testo rechargeable battery pack which is ready to operate, it can still run measurements and it can still be read out at a later stage.

Components	Part no.
Control unit incl. terminal plug	0563 0353
Testo rechargeable battery pack	0515 0097
Mains unit for control unit	0554 1084
Logger	0577 4540
Testo rechargeable battery pack	0515 0097
Databus cable (2 m)	0449 0042
Option:	
Touchscreen with pen	0440 0559
ComSoft 3 software	0554 0841

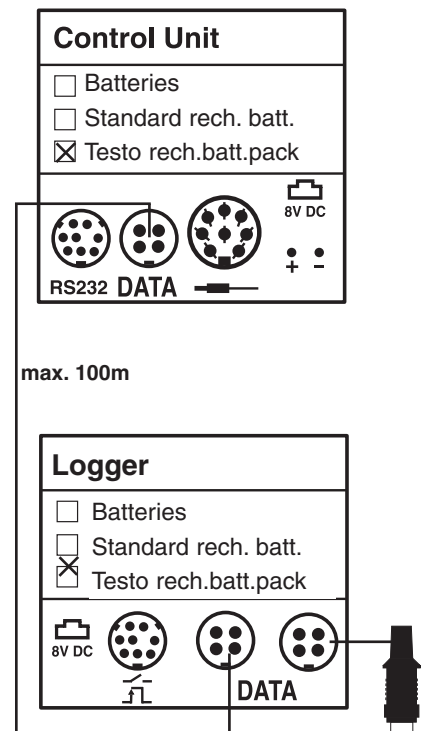

Charging rechargeable batteries

If the 0554.1084 mains unit is attached to the control unit, the Testo rechargeable battery pack in both the control unit and the logger are recharged. Recharging can be accelerated by attaching a mains unit (0554.1084) to the logger.

1. Description of the system components

1.10 System examples of testo 454 logger

1.10.1 Systems with control unit

Control unit and 1 logger via Testo databus with mains units

Maximum databus length is 1000 m when power is supplied by 2 mains units.

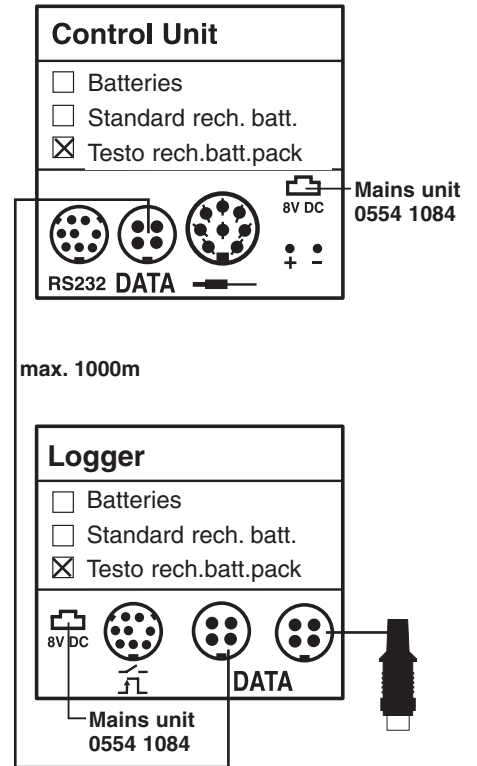

1.10.1.4 Control unit and 2 Loggers

Control unit with 2 plugged in loggers

A power box is required for mobile applications using the control unit with 2 plugged in loggers.

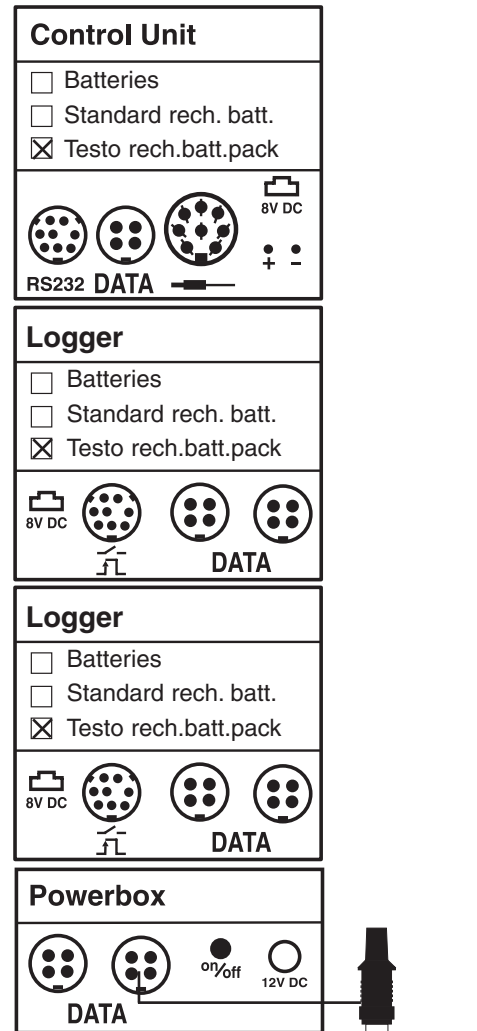

1. Description of the system components

1.10 System examples of testo 454 logger

1.10.1 Systems with the control unit

The power box is recharged via the mains unit for the power box (switched on). Recharging can be accelerated by additional mains units (0554.1084).

Components	Part no.
Control unit incl. terminal plug	0563 0353
Testo rechargeable battery pack	0515 0097
Logger	0577 4540
Testo rechargeable battery pack	0515 0097
Logger	0577 4540
Testo rechargeable battery pack	0515 0097
Power box	0554 1045
Mains unit for power box	0554 1143
Option:	
Touchscreen with pen	0440 0559
Software ComSoft 3	0554 0841

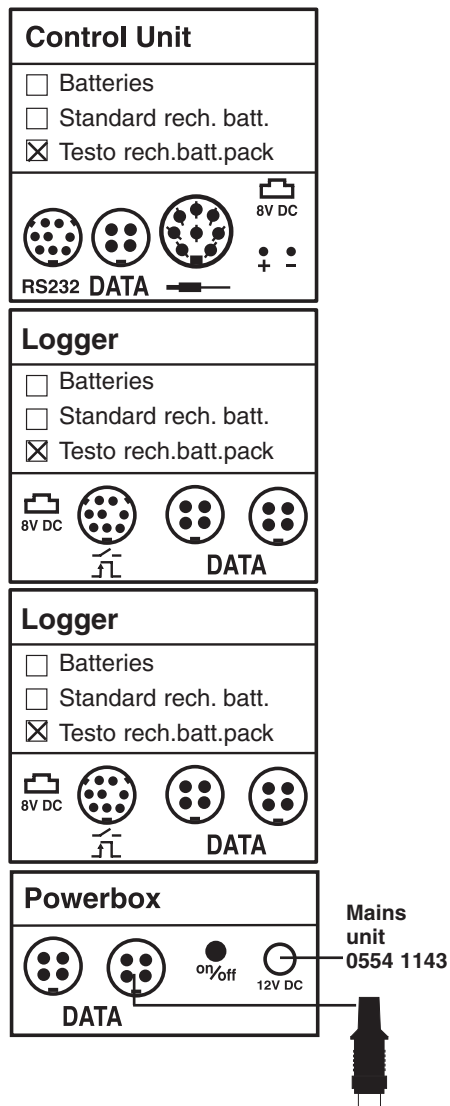

1. Description of the system components

1.10 System examples of testo 454 logger 1.10.1 Systems with control unit

Control unit and 2 loggers via Testo databus with mains units

3 mains units are absolutely necessary for operation.

Databus length = L1 + L2

Max. databus length = 600m

Components	Part no.
Control unit incl. terminal plug	0563 0353
Mains unit for control unit	0554 1084
Logger	0577 4540
Mains unit for logger	0554 1084
Logger	0577 4540
Mains unit for logger	0554 1084
Databus cable (2 m)	0449 0042
Databus cable (5 m)	0449 0043
Option:	
Touchscreen with pen	0440 0559
Software ComSoft 3	0554 0841

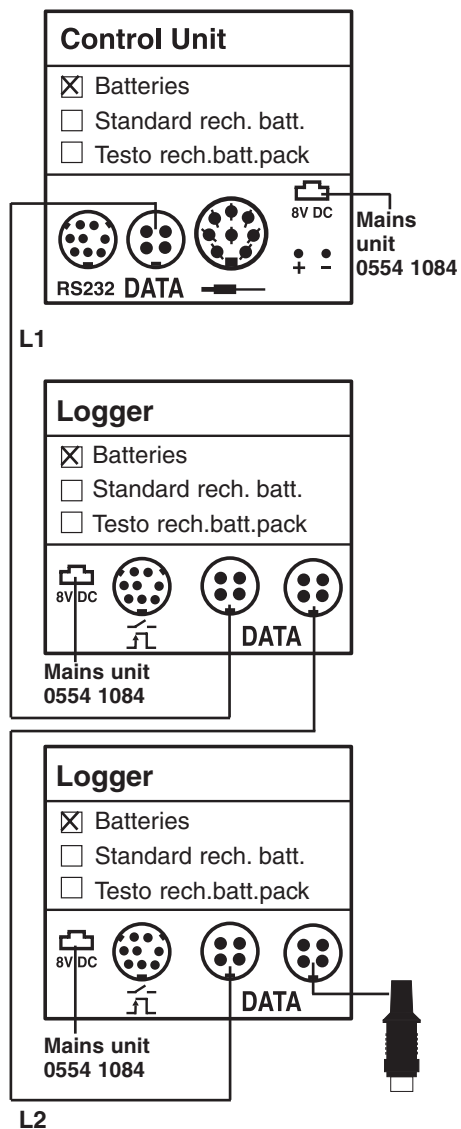

1. Description of the system components

1.10 System examples of testo 454 logger

1.10.1 Systems with control unit

Power supply via a Testo power box

If power cannot be supplied to the logger via mains unit, power can then be supplied via power box. The control unit can be operated via mains unit.

Databus length = L1 + L2

Maximum databus length = 100m

Components	Part no.
Control unit incl. terminal plug	0563 0353
Mains unit for control unit	0554 1084
Testo rechargeable battery pack	0515 0097
Logger	0577 4540
Testo rechargeable battery pack	0515 0097
Logger	0577 4540
Testo rechargeable battery pack	0515 0097
Power box	0554 1045
Mains unit for power box	0554 1143
Databus cable (2 m)	0449 0042
Databus cable (5 m)	0449 0043
Option:	
Touchscreen with pen	0440 0559
Software ComSoft 3	0554 0841

Rechargeable battery is recharged via power box mains unit (0554 0143).

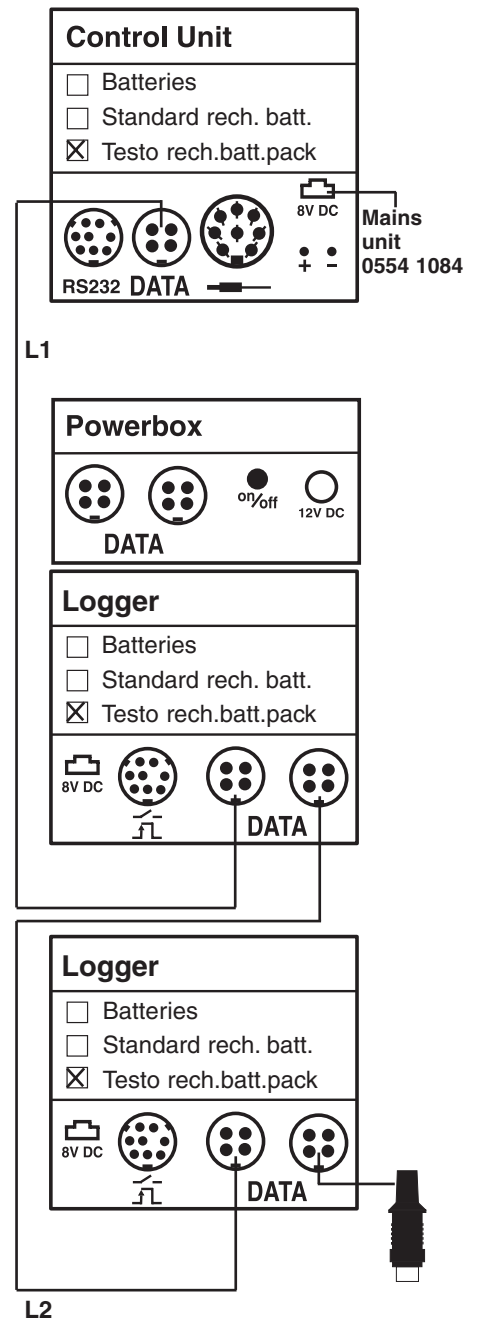

1. Description of the system components

1.10 System examples of testo 454 logger 1.10.1 Systems with the control unit

1.10.1.5 Control unit and 3 loggers

Power supply via power box

Battery recharging

The Testo rechargeable battery pack is recharged via the power box (switched on).

Components	Part no.
Control unit incl. terminal plug	0563 0353
Testo rechargeable battery pack	0515 0097
Logger	0577 4540
Testo rechargeable battery pack	0515 0097
Logger	0577 4540
Testo rechargeable battery pack	0515 0097
Logger	0577 4540
Testo rechargeable battery pack	0515 0097
Power box	0554 1045
Mains unit for power box	0554 1143
Option:	
Touchscreen with pen	0440 0559
Software ComSoft 3	0554 0841

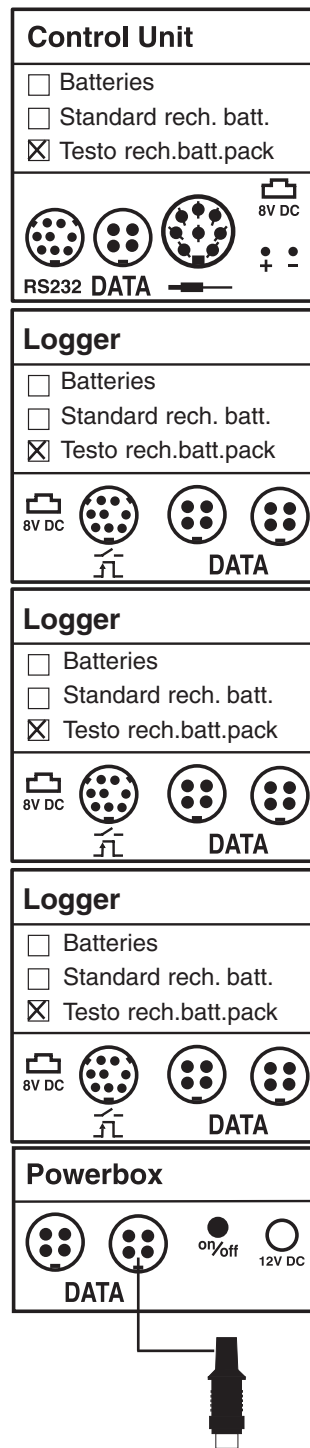

1. Description of the system components

1.10 System examples of testo 454 logger

1.10.1 Systems with the control unit

Power supply via Testo mains units

Mains units are absolutely necessary for operation.

Databus length = L1 + L2 + L3

Max. databus length = 500m

Components	Part no.
Control unit incl. terminal plug	0563 0353
Testo rechargeable pack	0515 0097
Mains unit for control unit	0554 1084
Logger	0577 4540
Testo rechargeable battery pack	0515 0097
Mains unit for logger	0554 1084
Logger	0577 4540
Testo rechargeable battery pack	0515 0097
Mains unit for logger	0554 1084
Logger	0577 4540
Testo rechargeable battery pack	0515 0097
Mains unit for logger	0554 1084
Databus cable (2 m)	0449 0042
Databus cable (5 m)	0049 0043
Databus cable (20 m)	0049 0044
Option:	
Touchscreen with pen	0440 0559
Software ComSoft 3	0554 0841

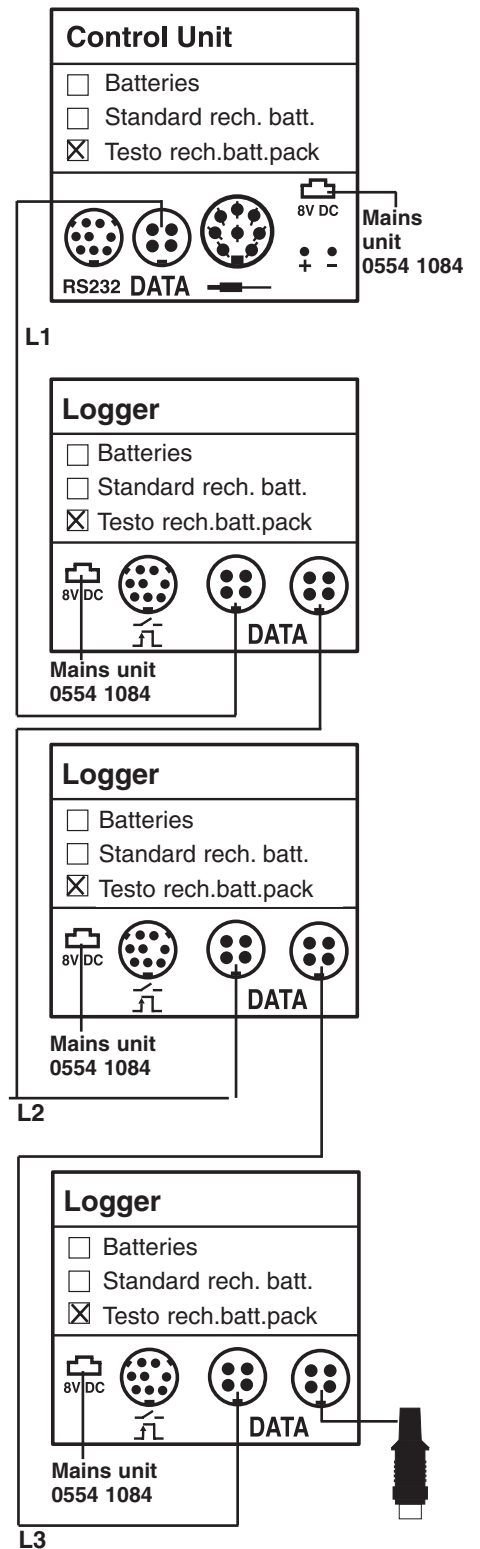

1. Description of the system components

1.10 System examples of testo 454 logger

1.10.1 Systems with control unit

Power supply via Testo power box Version 1

Databus length = L1 + L2 + L3

Max. databus length = 50m

Components	Part no.
Control unit incl. terminal plug	0563 0353
Testo rechargeable battery pack	0515 0097
Mains unit for control unit	0554 1084
Logger	0577 4540
Testo rechargeable battery pack	0515 0097
Logger	0577 4540
Testo rechargeable battery pack	0515 0097
Logger	0577 4540
Testo rechargeable battery pack	0515 0097
Power box	0554 1045
Mains unit for power box	0554 1143
Databus cable (2 m)	0449 0042
Databus cable (2 m)	0449 0042
Databus cable (2 m)	0449 0042
Option:	
Touchscreen with pen	0440 0559
Software ComSoft 3	0554 0841

Recharging is via the mains unit power box.

Recharging is accelerated by additional mains units (0554.1084).

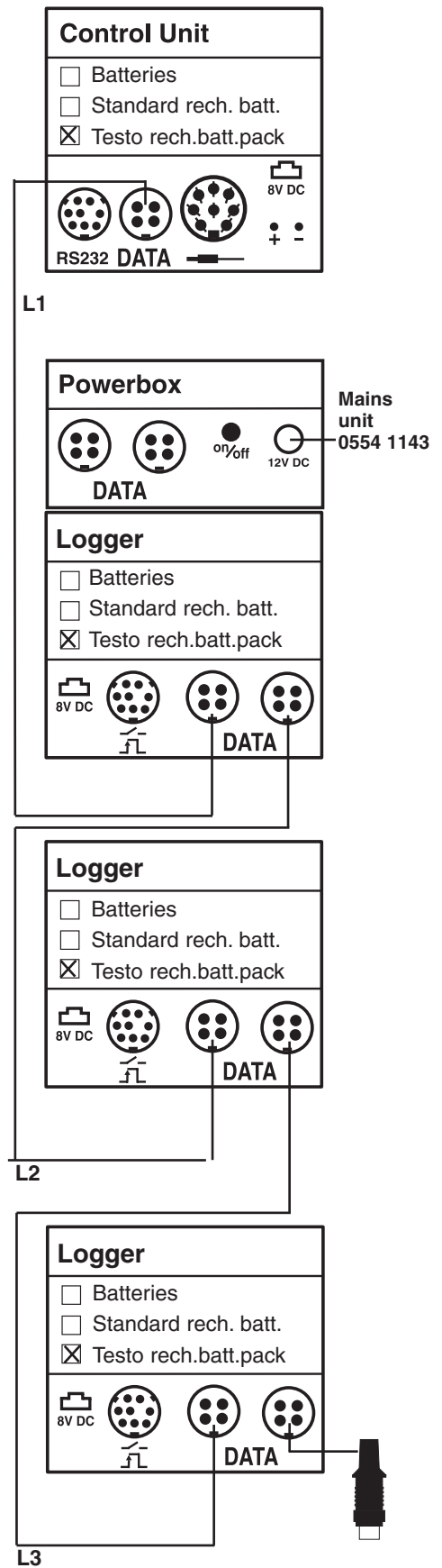

1. Description of the system components

1.10 System examples of testo 454 logger

1.10.1 Systems with control unit

Power supply via Testo power box Version 2

Databus cable = L1 + L2 + L3

Max. databus length = 50m

Components	Part no.
Control-Unit incl. terminal plug	0563 0353
Logger	0577 4540
Testo rechargeable battery pack	0515 0097
Logger	0577 4540
Testo rechargeable battery pack	0515 0097
Logger	0577 4540
Testo rechargeable battery pack	0515 0097
Power box	0554 1045
Mains unit for power box	0554 1143
1 terminal plug	0554 0119
Databus cable (2 m)	0449 0042
Databus cable (5 m)	0449 0043
Databus cable (20 m)	0449 0044
Option:	
Touchscreen with pen	0440 0559
Software ComSoft 3	0554 0841

Recharging is via the mains unit power box.

Recharging is accelerated by additional mains units (0554.1084)

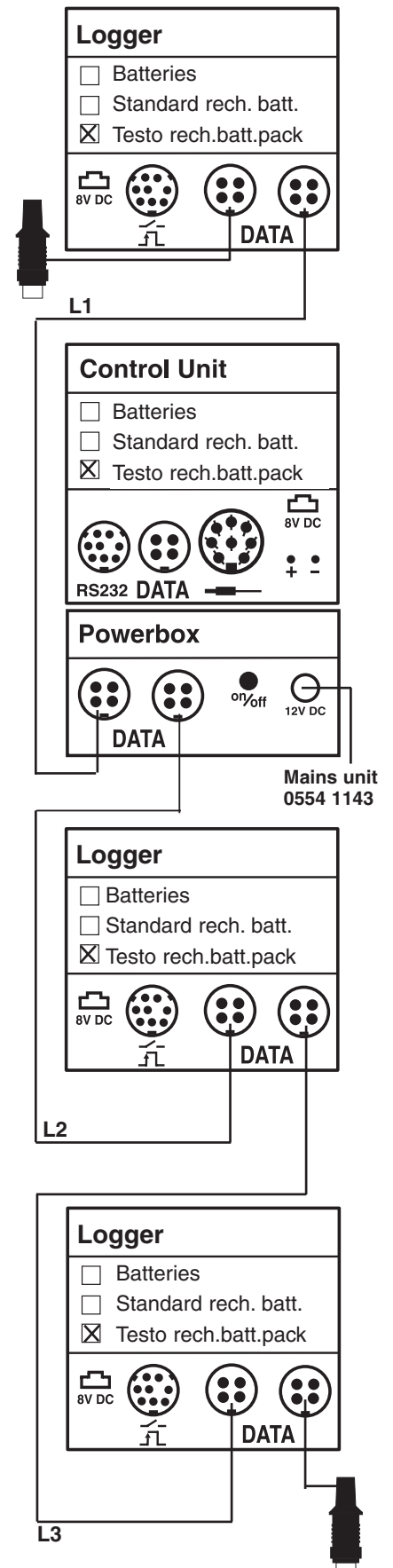

1. Description of the system components

1.10 System examples of testo 454 logger

1.10.1 Systems with the control unit

1.10.1.6 Control unit, logger and analog output box

Power supply via Testo rechargeable battery pack

Databus length = L1 + L2

Max. databus length = 150m

A mains unit (0554 1084) attached to the mA box is recommended

Components	Part no.
Control unit incl. terminal plug	0563 0353
Testo rechargeable battery pack	0515 0097
Logger	0577 4540
Testo rechargeable battery pack	0515 0097
Power box	0554 1045
Mains unit for power box	0554 1143
Analog output box	0554 0845
Mains unit for analog output box	0554 1084
Databus cable (2 m)	0449 0042
Databus cable (2 m)	0449 0042
Option:	
Touchscreen with pen	0440 0559
Software ComSoft 3	0554 0841

The cable can be extended by 150m to 250m by using additional mains units on control unit, analog box and logger.

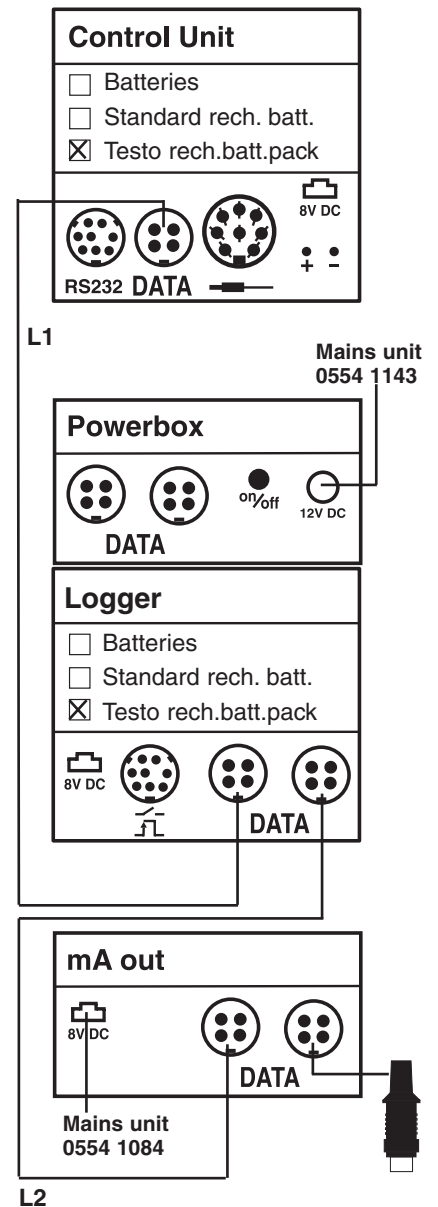

1. Description of the system components

1.10 System examples of testo 454 logger 1.10.2 Systems with the PCMCIA card

1.10.2.1 PCMCIA card and 1 logger

Power supply via Testo rechargeable battery pack

Databus length = L 1 + L 2

Maximum bus length = 150 m

Note

If thermal probes, CO₂ -probes are not used, the max cable length increases to 600m.

Components	Part no.
PCMCIA card incl. terminal plug	0554 0590
Logger	0577 4540
Testo rechargeable battery pack	0515 0097
Power box	0554 1045
Mains unit for power box	0554 1143
Databus cable (2 m)	0449 0042

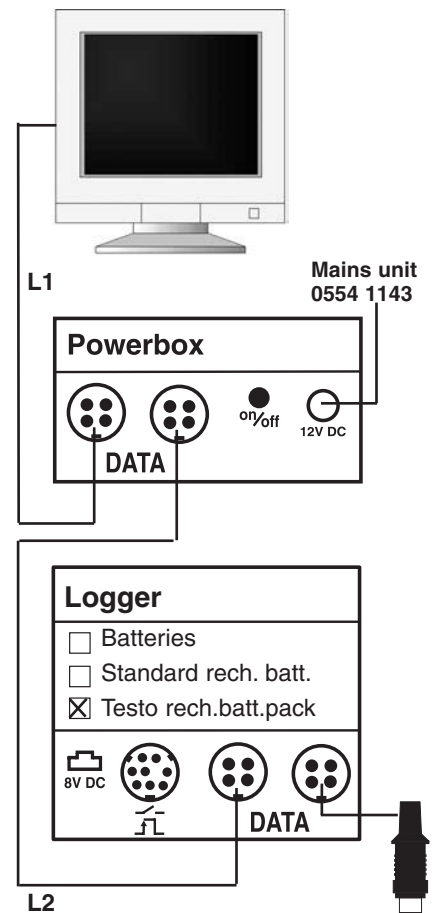

Power supply via Testo mains units

Databus length = L 1 + L 2

Maximum databus length = 1000 m

Components	Part no.
PCMCIA card	0554 0590
Logger	0577 4540
Mains unit for logger	0554 1084
Power box	0554 1045
Mains unit for power box	0554 1145
Terminal plug	0554 0119
Databus cable (2 m)	0449 0042

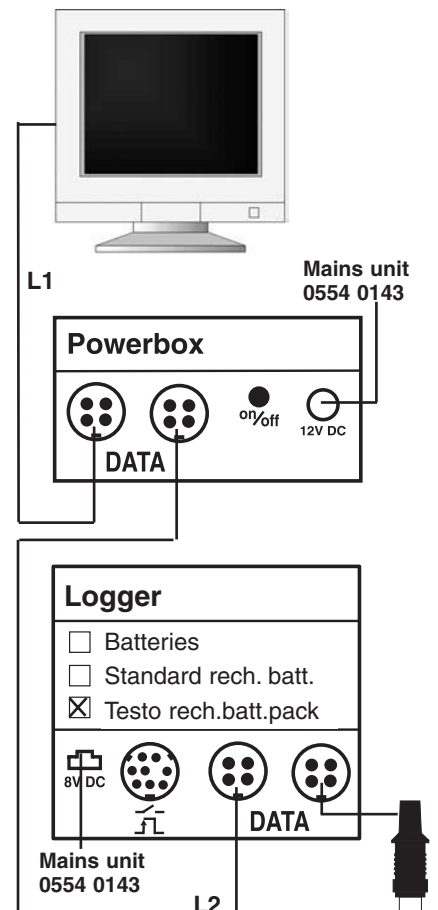

1. Description of the system components

1.10 System examples of testo 454 logger 1.10.2 Systems with the PCMCIA card

1.10.2.2 PCMCIA card and 2 loggers

Power supply via Testo rechargeable battery pack

Databus length = L 1 + L 2 + L3

Maximum databus length = 50 m

Note

If thermal probes, CO2 -probes are not used, the max cable length increases to 300m.

Components	Part no.
PCMCIA card	0554 0590
Logger	0577 4540
Testo rechargeable battery pack	0515 0097
Logger	0577 4540
Testo rechargeable battery pack	0515 0097
Power box	0554 1045
Main unit for power box	0554.1143
Terminal plug	0554 0119
Databus cable (2 m)	0449 0042
Databus cable (2 m)	0449 0042

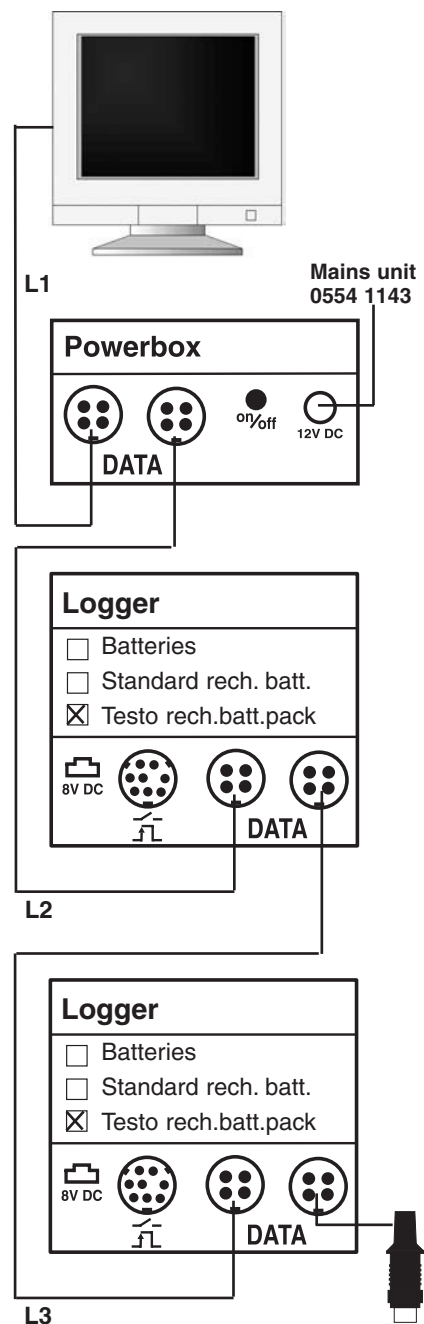

1. Description of the system components

1.10 System examples of testo 454 logger

1.10.2 Systems with the PCMCIA card

Power supply via Testo mains

Databus length = L 1 + L 2 + L3

Maximum databus length = 800 m

Components	Part no.
PCMCIA card	0554 0590
Logger	0577 4540
Mains unit for logger	0554 1084
Logger	0577 4540
Mains unit for logger	0554 1084
Power box	0554 1045
Mains unit for power box	0554 1143
Terminal plug	0554 0119
Databus cable (2 m)	0449 0042

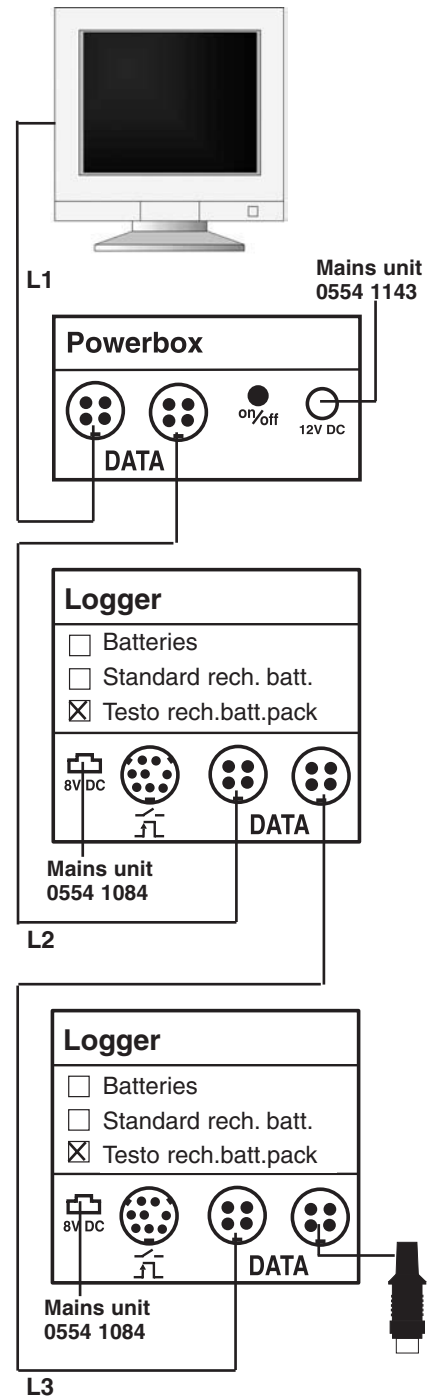

1. Description of the system components

1.10 System examples of testo 454 logger 1.10.2 Systems with the PCMCIA card

1.10.2.3 PCMCIA card and 3 loggers

Power supply via power box

Databus length = L 1 + L 2 + L3 + L4

Maximum databus length = 50 m

Note

If thermal probes, CO₂ -probes are not used, the max cable length increases to 200m.

Components	Part no.
PCMCIA card	0554 0590
Logger	0577 4540
Testo rechargeable battery pack	0515 0097
Logger	0577 4540
Testo rechargeable battery pack	0515 0097
Logger	0577 4540
Testo rechargeable battery pack	0515 0097
Power box	0554 1045
Mains unit for power box	0554.1143
Terminal plug	0554 0119
Databus cable (2 m)	0449 0042
Databus cable (5 m)	0449 0043
Databus cable (20 m)	0449 0044

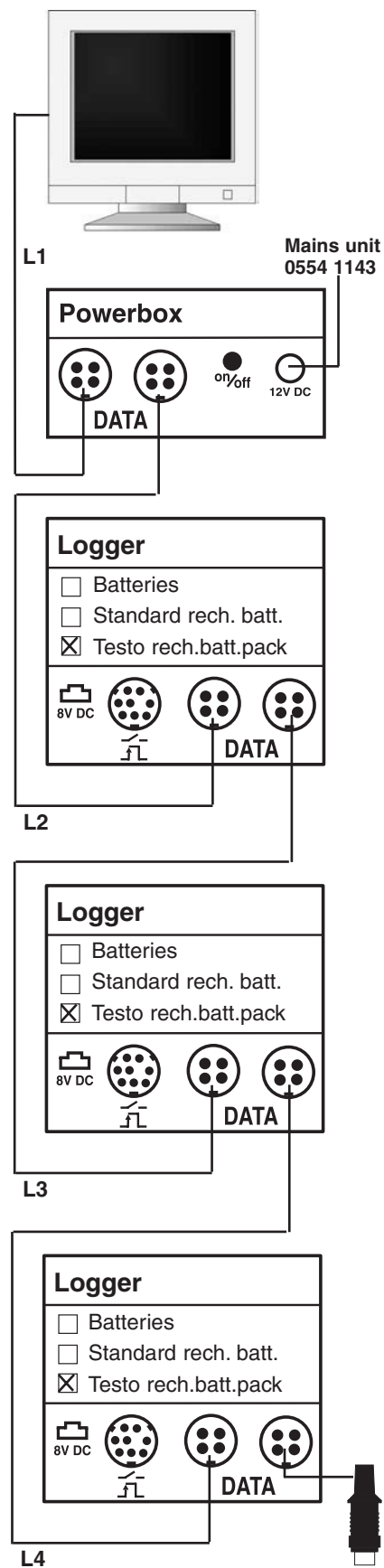

1. Description of the system components

1.10 System examples of testo 454 logger

1.10.2 Systems with the PCMCIA card

Power supply via Testo mains

Databus length = L 1 + L 2 + L3 + L4

Maximum databus length = 600 m

Components	Part no.
PCMCIA card	0554 0590
Logger	0577 4540
Mains unit for logger	0554 1084
Logger	0577 4540
Mains unit for logger	0554 1084
Logger	0577 4540
Mains unit for logger	0554 1084
Power box	0554 1045
Mains unit for power box	0554 1143
Terminal plug	0554 0119
Databus cable (2 m)	0449 0042
Databus cable (5 m)	0449 0043
Databus cable (20 m)	0449 0044

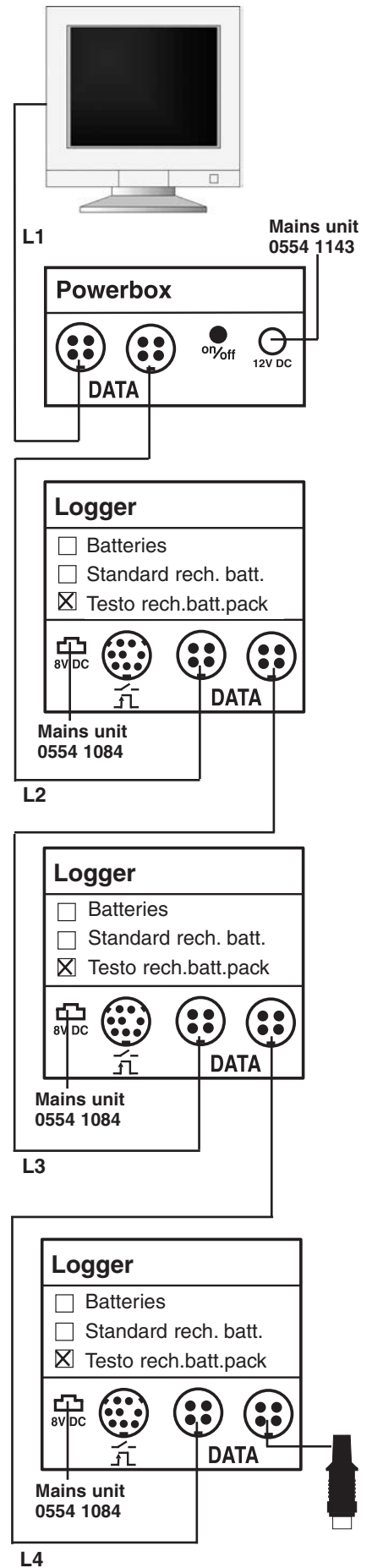

1. Description of the system components

1.10 System examples of testo 454 logger 1.10.2 Systems with the PCMCIA card

1.10.2.4 PCMCIA card, logger and analog output box

Power supply via Testo rechargeable battery pack

Databus length = L 1 + L 2

Maximum databus length = 1000m

The mains unit 0554.1084 is always recommended for the mA box.

Components	Part no.
PCMCIA card	0554 0590
Logger	0577 4540
Testo rechargeable battery pack	0515 0097
Power box	0554 1045
Mains unit for power box	0554 1143
Analog output box	0554 0845
Mains unit	0554 1084
Terminal plug	0554 0119
Databus cable (2 m)	0449 0042

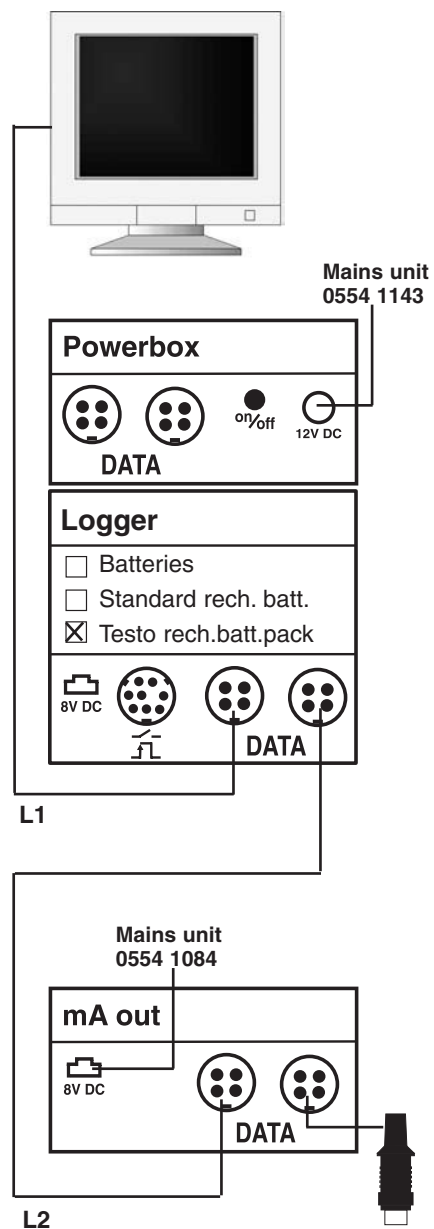

- Empty page -

1.11 HVAC probes



Adjustment

Temperature probes with EEPROM can be adjusted to a referential temperature e.g. by a calibration bath. Ideally, this temperature is applied at the point of the probe measurement. Following adjustment, the temperature readings taken by the probe are put on hold e.g. offset correction now takes place. An adjustment is only possible when an EEPROM temperature probe is connected to the Control Unit.

Performing an adjustment

- Press menu key .
- Select menu item **Probe** -> menu item **Adjust**.
- Input the referential temperature in the input dialogue box and confirm.

Info on adjusted probe

- Press menu key .
- Select menu item **Probe**.
- Select menu item **Info** -> **Probe socket 1**.

The Adjustment point and the offset factor are displayed under "Adjustment".

Resetting adjustment

- Press menu key .
- Select menu item **Probe** -> **Reset** -> **Probe socket 1**.
- Probe reset now takes place.

Probe adjustment can only be made via the reset function on the Control Unit.

Scaling

Scaling can be performed on the power/voltage cable (order no. 0554.007), the material moisture probe (art. 0636.0365) and the material/building humidity cable.

The probes can be connected to the Control Unit or the logger for scaling.

Resetting probe on Control Unit

The following are reset:

- Smoothing
- Surface allowance
- Reset adjustment
- Scaling

A reset for humidity calibration is not possible.

Resetting probe on logger

The following are reset:

- Smoothing
- Surface allowance
- Scaling

Calibration

Humidity probes 0636.9740, 0636.9715 and the three-function probe 0635.1540 are adjusted via the Control Unit.

- Press menu key .
- Select menu item **Probe**.
- Select menu item **Calibration** and **Calibration** to execute.

A reset can be performed for humidity adjustment.

1.12 Flue gas sampling probes

1.12.1 Standard sampling probes

1.12.2 Industrial sampling probes

1. Description of the system components

1.12 Flue gas sampling probes 1.12.1 Standard sampling probes

The standard sampling probes are equipped with integrated thermocouples to measure the flue gas temperature. These can be replaced by the user if necessary.

The hoses are available in a standard design and a special design for NO₂/SO₂ measurements (patented), see Ordering data for Ordering numbers.

A PTFE inner hose is used in this special design. This drastically increases the gas velocity – any droplets of condensation are propelled by the stream, preventing the absorption of NO₂ or SO₂.

Two designs of the probe pipe are available for 2 different temperature ranges (500 and 1,000 °C) and one outer pipe with filter. The design of your probe can be seen from the plate on the handle.

These probe pipes can be exchanged as necessary by releasing the bayonet union and pulling off the probe pipe. The other probe pipe can then be pushed on and tightened.

Caution!

- Always ensure that the probes and hoses are tightly sealed.
- If the flue gases bear dust and the special NO₂/SO₂ hose is used, the outer pipe equipped with a filter must be used to prevent deposits from accumulating or the gas path from becoming blocked.
- For maintenance instructions, see “Service and maintenance” chapter, subtopic “Flue gas analysis”.

The robust plug has three connections:

Red = gas path

Blue = differential pressure connection (observe +/-)

A round, eight-pole plug is fitted for the electrical connection of the thermocouple, which is plugged into the corresponding probe input of the Analyser Unit.

Leak test

A plastic cap to test for leaks is enclosed with the standard sampling probe (0193.0039).

Procedure:

- Measurement menu, or select flow display of pump under View
- Attach plastic cap on probe tip such that the countersinks are completely covered
- Start pump (**PStart**)
- Flow display less than 0.1l/min = probe and gas paths are leak-proof
- Flow display greater than 0.1l/min = leak in probe or gas path -> Check for leaks

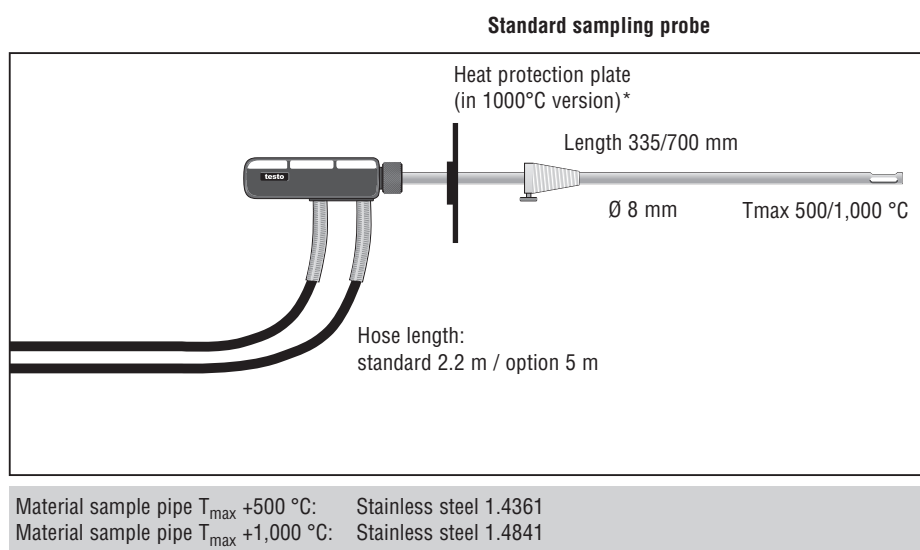

* The heat protection plate protects the handle if subjected to strong heat.

Connecting plug



1. Description of the system components

1.12 Flue gas sampling probes 1.12.2 Industrial sampling probes

The robust, modular industrial sampling probes are used for specific industrial applications. See the separate operating instructions for industrial flue gas probes for a description.

Important:

To connect these probes to the testo 350, the standard sampling hose (Part No.: 0554.3382) or the special sampling hose for NO₂/SO₂ measurement (0554.3384) must be used – do not use heated hoses!

Please also observe the separate operating instructions for the industrial sampling probes.

Typical example of an assembly of the industrial flue gas probes:

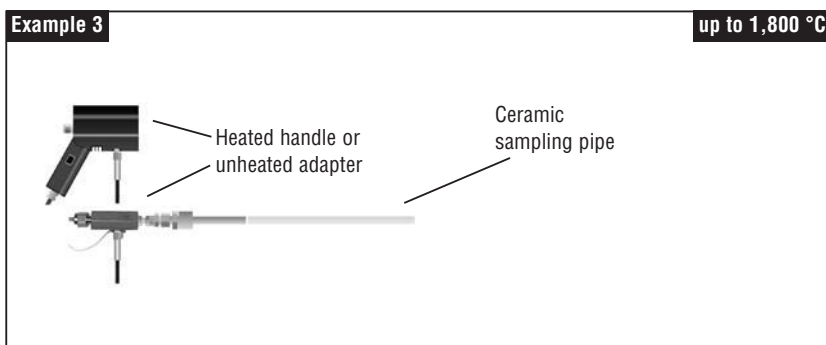
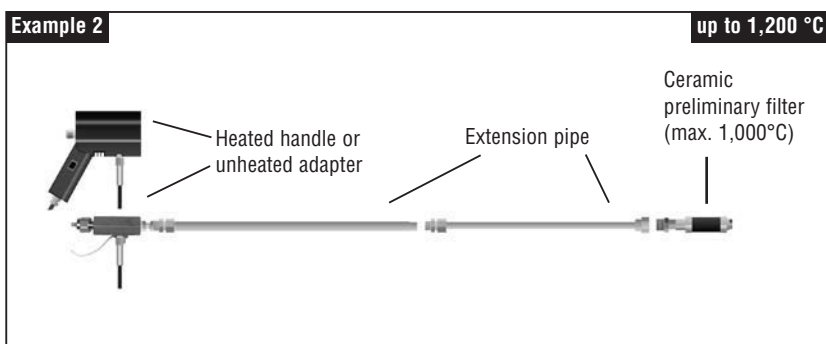
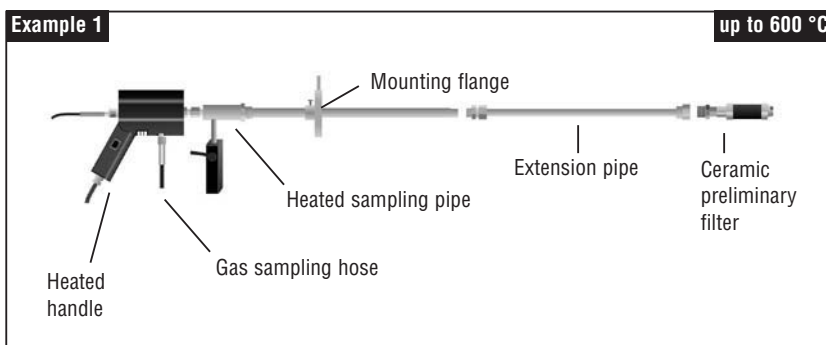

1.13 Flue gas probes from other manufacturers



1. Description of the system components

1.13 Flue gas probes from other manufacturers

Any desired type of special probe can be connected to the testo 350 M/XL. Ideally, the standard sampling hose, Part no. 0554.3382 or 0554.3384 is used for this purpose. If the screw nipple does not match, this can be removed from the hose and the hose can be connected as desired.

Notes:

- Ensure an adequate flow rate (diameter, filter etc.).
- An inner probe pipe with a small diameter is ideal to keep the gas volume as small as possible (to improve the response times and prevent absorption).
- Do not connect heated hoses directly to the testo 350! This can overload the gas preparation system.

1.15 testo 350 M/XL accessories

- 1.15.1 Hose set for conducting flue gas
- 1.15.2 Wall bracket for analyser box (Part no. 0554.0203)
- 1.15.3 Hood
- 1.15.4 Carrying strap set
- 1.15.5 Carrying case (black, with aluminium trim)
- 1.15.6 Service case (aluminium trim with drawer)/clip-on accessory box
- 1.15.7 Straight pitot tubes

1. Description of the system components

1.15 testo 350M/XL accessories

1.15.1 Hose set for conducting flue gas (Part no. 0554.0451)

In some cases, it is necessary to convey the flue gas from the outlets of testo 350 (e.g. during operation in a small, closed room).

The hoses in the hose set for conducting flue gas are designed such that pressure does not develop on the measurement cell since this would lead to incorrect measurement readings. The hose is 5m long.

Intended use:

The testo flue gas hose set is used to conduct flue gases away from the measuring instrument outside or to a safe place.

Safety information:

- Please ensure that the flue gases can be conducted away unhindered.
- The hoses should be laid such that the hoses are not bent.

1.15.2 Wall bracket for analyser box (Part no. 0554.0203)

The wall bracket consists of:

- Mounting bracket with pipe
- Heat shield for analyser box
- Lock

Installation:

The wall bracket (mounting bracket) can be either bolted to a wall or attached with one screw to a hole in a flange.

The analyser box is then clipped on and can be secured against theft with the lock.

Under conditions of strong thermal radiation, e.g. when attached directly to the flue, the heat shield is attached with the clips to the handle and protects the analyser unit from excessive heating.

Caution!

- **When attaching the wall bracket, please observe that it must support four times the weight of the instrument (i.e. 16 kg).**
- **The analyser must be attached in one of the 3 permissible positions: horizontal, vertical, hanging on the carrying strap.**

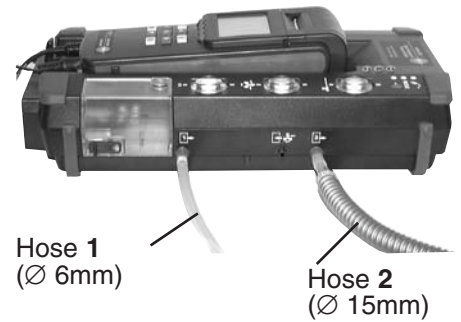

1. Description of the system components

1.15 testo 350M/XL accessories

1.15.3 Hood (Part no. 0554.0199)

The hood is intended to protect the analyser box and the connected Control Unit against dirt and moisture. The hood can also be used in conjunction with the wall bracket.

Put the hood with the cut-outs for the probe inputs downwards over the unit and plug the 3 nipples at the side onto the exhaust outlets. Attach the clip to the handle. This secures the hood against slipping or falling off.

Caution!

Do not use additional fasteners such as adhesive tape or the like.

The measuring instrument requires fresh air for cooling; the openings in the housing must not be obstructed.

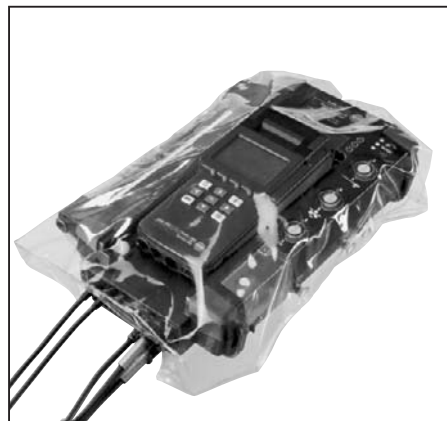

1.15.4 Carrying strap set (Part no. 0554.0434)

The carrying strap set consists of:

- Carrying strap with 2 carbine hooks
- 2 plastic clips
- Metal plate

The carrying strap set can be used either for the analyser box or for individual Control Units.

Snap the two plastic clips onto the handle of the analyser box to allow the carrying strap to be attached.

For the Control Unit, place the metal plate on the magnets on the rear and attach the carrying strap to the magnetic plate.



1.15.5 Carrying case (black, with aluminium trim) (Part no. 0516.0351)

The case is designed to allow the instrument to be operated whilst still in the case. However, ensure that the gases can escape unobstructed from the exhaust opening. For long-term measurements, we recommend the attachment of a hose to the condensate drain of the condensate vessel.

Caution!

Do not close the case during measurements to allow the flue gas to dissipate.

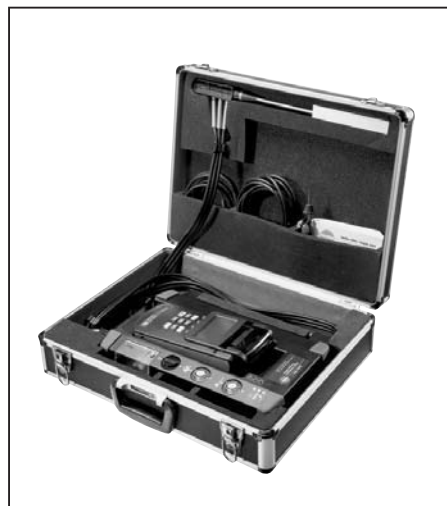

1. Description of the system components

1.15 testo 350M/XL accessories

1.15.6 Service case (aluminium trim with drawer)/ clip-on accessory box (Part no. 0516.0352)

The analyser box is attached in the case by the handle. The instrument is folded downwards to close the lid for carrying. In a contaminated atmosphere, the side can be folded upwards to protect the analyser unit in the case during operation and to allow the gas to escape unobstructed from the exhaust outlet.

For operation as a portable unit, lift the analyser box upwards, fold out the side holders and place the instrument on these. The unit is horizontal. The measurement results can then be read directly when a Control Unit is connected.

Clip-on accessory box for the service case (Part no. 0516.0353)

The accessory box can be clipped beneath the service case to hold further accessories, tools etc.



1.15.7 Straight Pitot tubes

Available lengths

360 mm Part no. 0635.2041

500 mm Part no. 0635.2042

In conjunction with a differential pressure probe, straight pitot tubes measure flow velocities. The temperature measurement is also integrated. The pressure probe produces the dynamic pressure from the difference of the total pressure and the static pressure.

The flow velocity is calculated as follows:

$$v = S \times \sqrt{\frac{2 \times P_{\text{dynamic}}}{\rho^*}}$$

S: pitot tube factor
 $P_{\text{dyn.}}$: dynamic pressure (Pa)
 ρ : density (kg/m³)

* In instruments with an input facility for the pitot tube factor (0.67), the flow velocity is calculated as follows:

$$v = S \times \sqrt{\frac{2 \times P_{\text{dynamic}}}{2.228 \times \rho}}$$

Technical data

Connecting hoses: 5 m
 Pitot tube factor: 0.67
 Minimum penetration depth: 150 mm
 Measuring range: 1...30 m/s
 0...+1000 °C

Pressure probes

Pressure probes	Measuring range
100 Pa Part no. 0638.1345	1...8 m/s
10 hPa Part no. 0638.1445	1...26 m/s
100 hPa Part no. 0638.1545	1...30 m/s

2. Description of the applications

- 2.1 Spot measurement of HVAC with the Control Unit
- 2.2 Measuring and storing with the Control Unit and a logger
- 2.3 Spot measurement of HVAC with PC plug-in card
- 2.4 Spot measurement of flue gas with base system – Control Unit
- 2.8 Long-term measurement of HVAC with the Control Unit
- 2.9 Long-term measurement of HVAC with the Control Unit and logger
- 2.10 Long-term measurement of HVAC with PC plug-in card
- 2.12 Long-term measurement of several boxes with PC plug-in card
- 2.13 Long-term measurement of flue gas with the base system – Control Unit
- 2.14 Long-term measurement of flue gas with the base system –Testo databus
- 2.19 Online PC RS-232 – Control Unit
- 2.21 Online PC RS-232 with one or more loggers
- 2.22 Online PC RS-232 – base system, flue gas
- 2.23 Online PC RS-232 – operation with one or more analyser boxes

2.1 Spot measurement of HVAC with the Control Unit



2. Description of the applications

2.1 Spot measurement of HVAC with the Control Unit

Requirements

Readings can be displayed or printed locally and also stored in the Control Unit, during which it is possible to assign the results of the measurement to the respective location. Measurements recorded by the instrument can be systematically evaluated at a later date.

Operation on the basis of an example measuring task

Measurement and documentation of velocity, temperature and humidity with a triple-function probe at 5 different locations in one building.

1. Connect the probe

The triple-function probe is connected to the probe socket of the Control Unit by the plug-in cable.

Caution!

Probes are only detected by the Control Unit when connected before switching on.

2. Switch on the Control Unit

After the Control Unit has been switched on and a brief initialisation phase has elapsed, the readings of the connected probe and of the pressure sensor installed in the Control Unit are displayed.

3. Printing the current readings

The current readings are printed by the printer integrated in the Control Unit by pressing function key **Print**. If this function is not visible in the current function key assignment, move to the other assigned function keys with **◀** or **▶**. Otherwise, the printing function must first be assigned to a function key. Open the selection list by pressing **☐**, releasing and immediately pressing the function key to be assigned **●**. Select the function key with the cursor keys **▲** or **▼** and confirm with **OK**. (See also chapter 1.15)

4. Assigning readings to a location and storing

The current readings can be stored in the memory of the Control Unit at any time by pressing function key **Mem.**. To maintain clarity in large volumes of data, each reading is always stored under a location. The current location is always shown in the top line of the display.

5 Entering a new location

The location menu is opened by pressing the **OK** and **◀** keys.

Control Unit

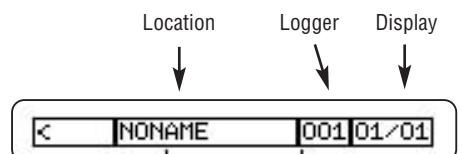
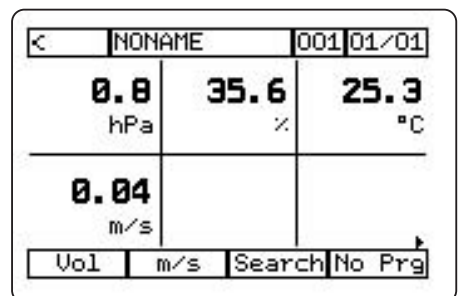

2. Description of the applications

2.1 Spot measurement of HVAC with the Control Unit

Memory management makes it possible to consolidate several locations in a folder in a manner similar to the data management of PC operating systems.

6. Location, folder

With **OK** → **◀**, the desired location or a folder, which can contain further locations, can be selected.

The next higher directory level can be accessed with **ESC**.

Function key **Change** makes it possible to create new locations and also new folders.

When a new location has been selected, this is indicated in the top bar of the display.

When the triple function probe has been positioned at the desired location and function key **Mem.** has been pressed, all parameters of the connected probe and of the pressure sensor integrated in the Control Unit are stored under the selected location, specifying the current date and the current time.

Several measurements can be made and stored at the same location. The date and time make it possible to explicitly identify the data protocols.

7. Reading data from memory and printing with the integrated printer

Stored readings can be viewed for assessment or verification at any time:

For this, select the location as described above in “Entering a new location”. The name of the location appears in the top line of the display. Pressing

☞ → **Memory** → **OK** → **Read-out** → **OK**

produces a list of the data protocols stored under this location.

When the desired data protocol is chosen with **▲** **▼** → **OK**, the stored readings are displayed.

8. Print

Print prints the data protocol on the integrated printer.



Location



Folder

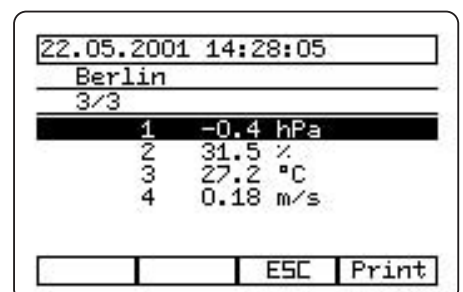
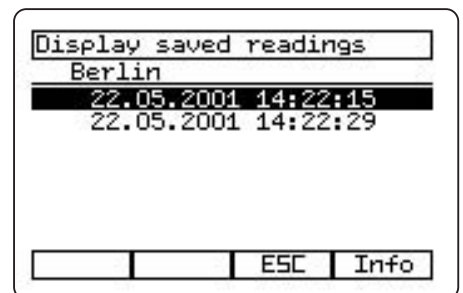
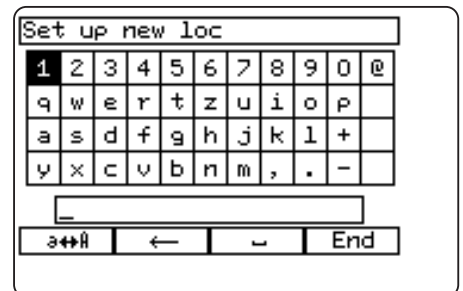

2.2 Measuring and storing with the Control Unit and a logger



2. Description of the applications

2.2 Measuring and storing with the Control Unit and a logger

Operation on the basis of an example measuring task:

1. Connect probes, Control Unit and logger

Place the Control Unit and the logger one above the other (2 red arrows indicate the position) and push together until they engage audibly. This makes all necessary electrical connections between the logger and the Control Unit.

A velocity probe, a CO₂ probe and a humidity probe are connected to the probe sockets 1...3 of the logger (see markings on the plug cover).

Caution: Probes are only detected by the Control Unit and the logger when connected before switching on.

2. Switch on the Control Unit

When the  key is pressed, both the Control Unit and the logger are switched on (green LED on the logger lights steadily) and an initialisation phase is conducted.



The reading display of the Control Unit appears briefly, indicating the pressure probe socket.

3. Display of the readings

When the initialisation phase of the logger is complete (usually a little longer than the Control Unit), the reading display of the logger 454 appears automatically. The readings are displayed in the sequence of the probe socket connections.





1. Probe socket 1, rel. humidity
2. Probe socket 2, air temperature
3. Probe socket 3, air velocity
4. Probe socket 3, ppm CO₂ probe

Over 6 readings may be involved, depending on the number and types of the connected probes.

In this case, it is possible to scroll between the displays using  , during which the current displayed page is indicated in the top right line of the display.

4. Probe socket of Control Unit or logger (testo 454)

To retain a constant overview of all readings, it is advisable to connect both probes to the logger, as only the readings of the probes of the logger or the Control Unit can be displayed simultaneously.

 branches from the reading menu to the selection menu for the display and operation of the individual units (Control Unit, logger, analog output box or powerbox). Selection with   and  or .

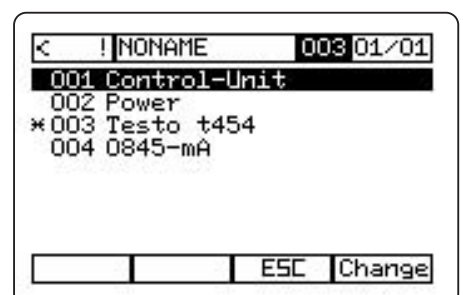
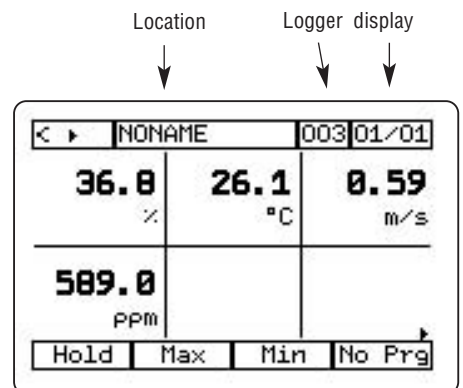
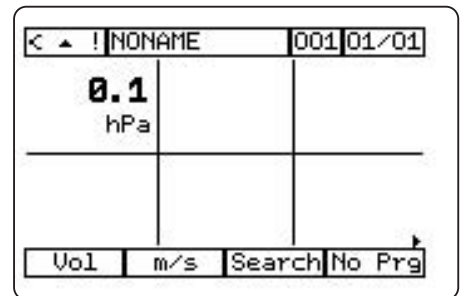

2. Description of the applications

2.2 Measuring and storing with the Control Unit and a logger

5. Printing the current readings

When function key **Print** is pressed, the current readings of all probes of the unit selected on the display (Control Unit or testo 454 logger) are printed by the printer integrated in the Control Unit. If the function **Print** is not visible in the current assignment of the function keys, the function must first be assigned to a function key: **□** → immediately **■** (desired function key) → **▲** → **▼** → **OK**.

6. Assigning readings to a location and storing

The current readings can be stored in the memory of the logger (or the Control Unit) at any time by pressing function key **Mem.**.

Important: The readings are stored in the unit (logger or Control Unit) to which the probe is connected.

To maintain clarity in large volumes of data, each reading is always stored under a location. The current location is always displayed in the top line of the display.

7. Entering a new location

The location menu is opened by pressing the **OK** and **◀** keys.

Memory management makes it possible to consolidate several locations in a folder in a manner similar to the data management of PC operating systems.

8. Location, folder

With **OK** → **◀**, the desired location or a folder, which can contain further locations, can be selected.

The next higher folder level can be accessed with **ESC**.

Function key **Change** makes it possible to create new locations and also new folders.

When a new location has been selected, this is indicated in the top bar of the display.

When the triple probe and the CO₂ probe have been positioned at the desired location and function key **Mem.** is pressed, all parameters of the connected probe are stored under the selected location, specifying the current date and the current time.

Several measurements can be made and stored at the same location. The date and time make it possible to explicitly identify the data protocols.

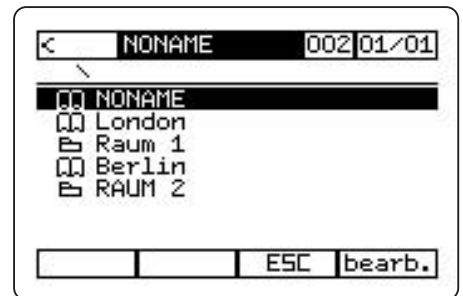
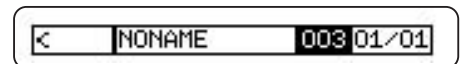

Location



□ London

Folder



▢ RAUM 2

2. Description of the applications

2.2 Measuring and storing with the Control Unit and a logger

9. Reading out data from memory and printing with the integrated printer

Stored readings can be viewed for assessment or verification at any time:

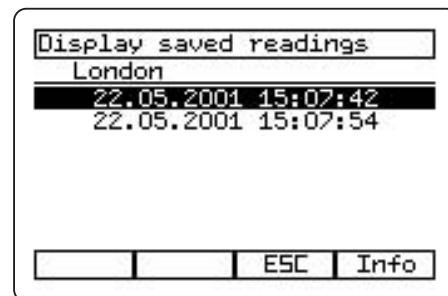

The desired location is selected as described under “Entering a new location” (see above) for this purpose. The location name appears in the top line of the display and



 -> **Memory** -> **OK** -> **Read-out** -> **OK**

produces a list of the data protocols stored under this location.

10. Display of the stored readings

When the desired data protocol is chosen with   -> **OK**, the stored readings are displayed.

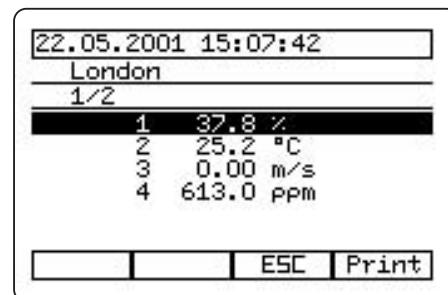

11. Print

Print prints the data protocol on the integrated printer.

2.3 Spot measurement of HVAC with PC plug-in card



2. Description of the applications

2.3 Spot measurement of HVAC with PC plug-in card

Requirements

- You have installed the interface (chapter 1.7) and ComSoft (chapter 1.8).
- A logger is connected by the 4-pole bus data line to the PCMCIA card.
- The bus supply is provided either by a powerbox or by connecting a bus supply mains adapter at the second 4-pole data socket of the logger.
- One or more probes are connected to the logger, the logger is supplied by internal batteries or rechargeable batteries or by a separate 8 V mains adapter.

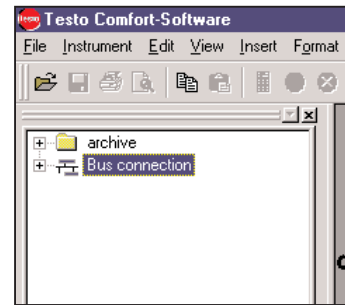

Operation

Start the Comfort-Software, click with the right mouse button on the “Bus connection” icon in the archive section and execute the first item of the appearing menu **Open**.

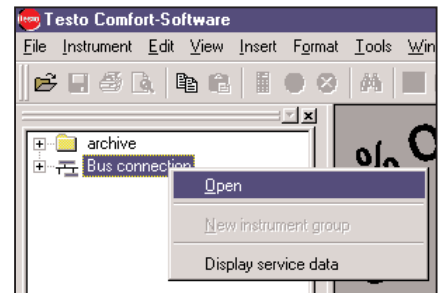

Shortly afterwards, the icons of the connected instruments appear. Select one and then open the instrument menu with the right mouse button to activate the instrument.

When the device is activated, the online measurement is simultaneously enabled. The green start button for the online measurement appears in the icon bar. Alternatively, the online measurement can be started using the main menu item **Instrument** or in the instrument menu itself. Clicking on the start button directly opens the online measurement in table view. The channels of all probes connected to the logger are displayed concurrently.

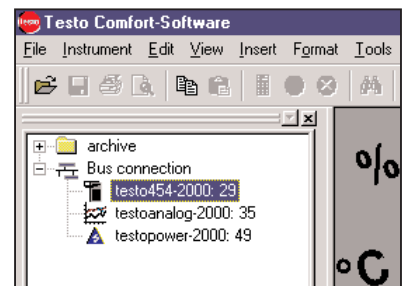

The type of display can be changed using the icons in the icon bar, e.g. it is possible to change to a diagram or 7-segment display. You can store the data recorded to date on the hard disc at any time with the **Save file as** command.

For further facilities, see the operating instructions for ComSoft3, “Example 1” and “Example 3”.

2.4 Spot measurement of flue gas with base system – Control Unit

- 2.4.1 Initial operation
- 2.4.2 Reading out the stored values
- 2.4.3 Changing readings window
- 2.4.4 Differential pressure measurement with analyser box
- 2.4.5 Velocity measurement with analyser box
- 2.4.6 Changing between the Control Unit and the analyser box
- 2.4.7 Fuel selection
- 2.4.8 Changing locations
- 2.4.9 Changing the display
- 2.4.10 $\text{CO}_{2\text{max}}/\text{O}_{2\text{rel}}$
- 2.4.11 HC on/off
- 2.4.12 Switching off CO, NO, NO₂, SO₂, HC

2. Description of the applications

2.4 Spot measurement of flue gas with base system – Control Unit 2.4.1 Initial operation

Requirements

Insert the flue gas probe in the flue and connect to the instrument.

Flue gas probe



Analyser box



The measurement of the flue gas temperature is made by the thermocouple at the tip of the flue gas probe. The probe pipe protects the thermocouple, but has openings to allow the stream of flue gas to envelope the thermocouple.

Note

Connect the flue gas probe before switching on the Control Unit and the analyser box.

Positioning the flue gas probe in the flue gas stream

The thermocouple must always be exposed to the stream of flue gas to allow an exact measurement of the flue gas temperature and thereby a precise determination of the flue gas losses. It must not be screened by a web of the probe pipe.

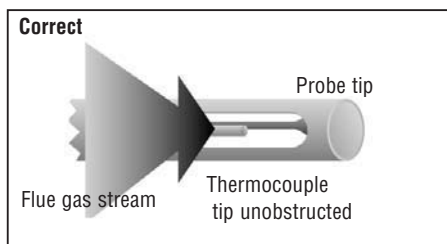
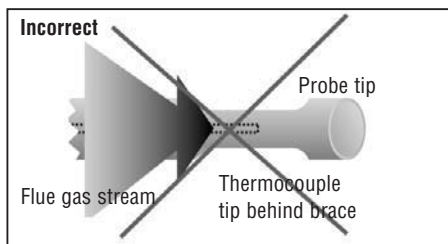

Thermocouple tip

The tip of the thermocouple must not touch the guard! If necessary, bend the tip of the thermocouple accordingly.

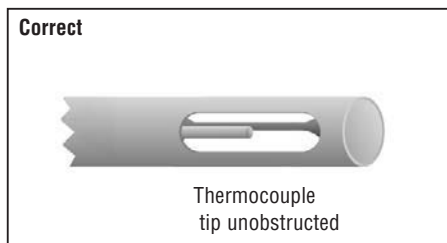
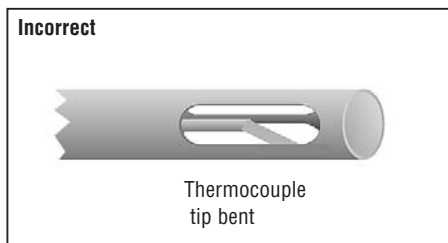

2. Description of the applications

2.4 Spot measurement of flue gas with base system – Control Unit 2.4.1 Initial operation

Connect flue gas probe - Switch on the instrument – the zeroing phase is conducted. Any connected CO probe and the gas measuring cells of the analyser box are zeroed during the zeroing phase.

The temperature measurement is conducted during the zeroing phase and is indicated on the display. The measured temperature of the flue gas probe is interpreted by the testo 350M/XL as the combustion air temperature and is stored as the combustion air temperature value after the zeroing phase. If another combustion air probe is connected to the analyser box or the Control Unit, this temperature value is displayed and stored.

All dependent parameters are calculated by this value.

The fresh air required for the zeroing phase is drawn in through the exhaust if no fresh air valve is installed and through the valve inlet if a fresh air valve is installed. In this way the flue gas probe can be located in the flue gas duct before or during the zeroing phase.

During the zeroing phase, the instrument verifies the zero point and the drift of the gas sensors. The O2 probe is also set to 21 %O2.

Caution!

Ensure that no interfering gases such as CO, NO ... are in the surrounding air.

Operation

The instrument branches automatically to the reading display (set fuel if necessary).

PStart starts the measurement. Scroll through the measurement windows with **◀** or **▶**. The proceeding measurement is indicated in the start display by a flashing “o”.

The measurement can be stopped with **PStop** - the values are “frozen”.

Print if required → **Print**

Store if required under selected reading **Mem.** - manual storing of individual measurements.

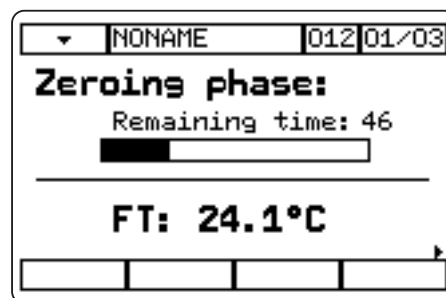

Status display reading window

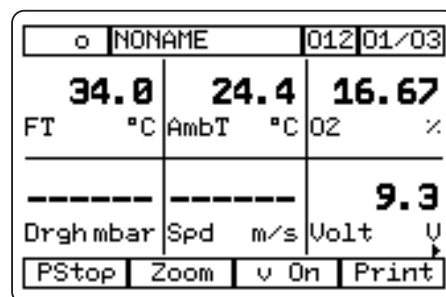
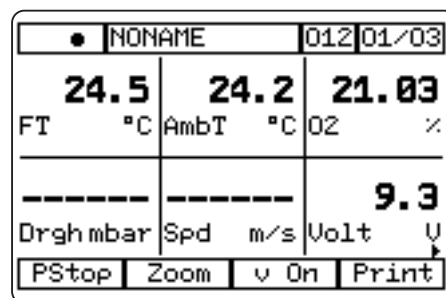
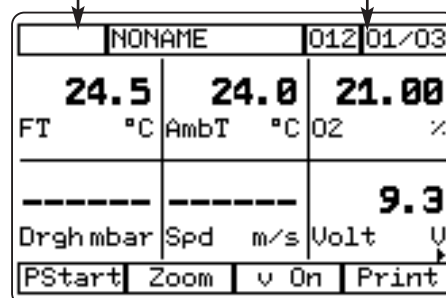

Note

The analyser box does not need to be activated in the instrument selection menu. It is detected automatically when the measuring unit starts.

2. Description of the applications

2.4 Spot measurement of flue gas with base system – Control Unit

2.4.1 Initial operation

Switch-off phase

When switched off, the analyser box checks whether flue gases are still in the sensors. Rinsing with fresh air continues until e.g. 20.5 %O₂ is reached. After the switch-off phase, the instrument enters battery charging mode if a mains adapter is connected.

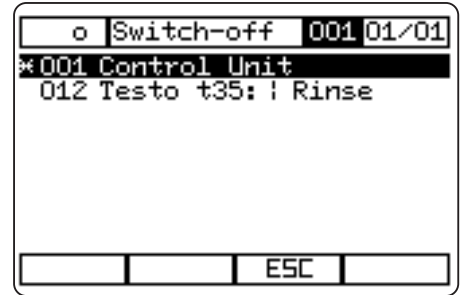

Note



It is normal for the fan to run on or run during charging when the mains cable is connected.

2. Description of the applications

2.4 Spot measurement of flue gas with base system – Control Unit 2.4.2 Reading the stored values

Connect analyser box and Control Unit; switch on Control Unit

with  -> **Memory** -> **Read-out**.

Select reading with the cursor keys , .

Confirm with key **OK**.

Return to reading display with **OK**.

Readings display

NONAME		012/01/03	
23.8	24.9	21.00	
FT °C	AmbT °C	O2	%
-----		9.3	
Drghmbar	Spd m/s	Volt	U
PStart	Zoom	v On	Print

↓

02.01.2000 02:18:38		
O2	AT	UT
%	°C	°C
4.4	231.2	30.9
4.4	229.9	30.9
4.4	230.7	31.0
4.5	229.9	30.9
4.4	230.0	30.9
4.4	230.5	30.9
▲	▼	ESC Print

Main menu

↓ 

Meas. progs. / Readings	
Memory	24.9 21.00
Sensors	mbT °C O2 %
F Input	-----
Device	9.3
Service	-----
Drghmbar	Spd m/s Volt U
ESC OK	

↓ **OK**

Display saved readings	
M Read out	21.00
F Program	O2 %
Delete memory	-----
free memory?	9.3
Drghmbar	Spd m/s Volt U
ESC OK	

↓ **OK**

Display saved readings	
NONAME	
26.02.2003 13:33:32	
26.02.2003 13:35:32	
26.02.2003 14:59:12	
26.02.2003 15:00:16	
26.02.2003 15:00:57	
ESC Info	

↓  **OK** 

4x **ESC**
Readings display

2. Description of the applications

2.4 Spot measurement of flue gas with base system – Control Unit 2.4.4 Differential pressure measurement with analyser box

Connect analyser box and Control Unit, switch on Control Unit.

Caution!

Pressure inlet must be depressurised.

Start measurement with function key **dP**.

Sensor configures automatically.

Apply pressure.

Display of the current reading.

Return to readings display with **OK** key.

Readings display

NONAME		012 01/03	
23.8	24.9	21.00	
FT °C	AmbT °C	O2	%
-----	-----	9.3	
Drghmbar	Spd m/s	Volt	V
PStart	Zoom	v On	Print



Memory

Automatic sensor zeroing

Delta P			
Zeroing sensor			
4			
		ESC	



6 sec

Result

Delta P			
-0.0 mbar			
		ESC	OK

OK

Readings display

2. Description of the applications

2.4 Spot measurement of flue gas with base system – Control Unit 2.4.5 Velocity measurement with analyser box

Connect analyser box and Control Unit, switch on Control Unit.

Caution!

Pressure sockets must be depressurised (ambient pressure applied).

Start measurement with function key **vEin**.

Sensor zeroes automatically.

Apply pressure/place pitot tube in the channel.

Stop measurement with function key **vOut**.

Readings display

NONAME		012	01/03
23.8	24.9	21.00	
FT	°C	AmbT	°C O2 %
-----		9.3	
Drghmbar	Spd	m/s	Volt U
PStart	Zoom	v On	Print



v On

Automatic sensor zeroing

m/s			
Zeroing sensor			
4			
		ESC	



6 sec

Readings display

NONAME		012	01/03
21.0	20.8	21.00	
FT	°C	AmbT	°C O2 %
0.02	1.9	9.5	
Drghmbar	Spd	m/s	Volt U
PStart	DeltaP	v Off	Print



v Off

Readings display

NONAME		012	01/03
21.0	20.8	21.00	
FT	°C	AmbT	°C O2 %
0.02	1.8	9.5	
Drghmbar	Spd	m/s	Volt U
PStart	DeltaP	v On	Print

Note:

- The ambient pressure must be entered for a correct velocity measurement:
 → →
- Check the adjusted pitot tube factor according to the pitot tube in use:
 →
- For mass flow, the channel cross-section and the dew point of the surrounding air must also be entered. (Alternatively: from humidity and temperature.)
- A temperature probe has to be inserted in the analyser box (flue gas temperature socket) in order for velocity to be displayed.

2. Description of the applications

2.4 Spot measurement of flue gas with base system – Control Unit

2.4.6 Changing between Control Unit and analyser box

Readings display

NONAME		012 01/03	
23.8	24.9	21.00	
FT °C	AmbT °C	O2	%
-----	-----	9.3	
Drghmbar	Spd m/s	Volt	U
PStart	Zoom	v On	Print

OK

Unit selection window

NONAME		012 01/01	
001 Control Unit			
*012 Testo t35: Meas.			
		ESC	Change

▲
▼

OK

Readings display

Loc 1		001 01/01	
41.8	21.9	0.00	
%	°C	m/s	
Max	Min	Mean	Search

Hint

Always think "in boxes".

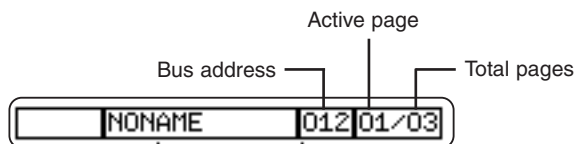

2. Description of the applications

2.4 Spot measurement of flue gas with base system – Control Unit 2.4.8 Changing locations

Connect the analyser box and the Control Unit, switch on Control Unit.

With key **OK** to the box selection window.

Continue with cursor key **◀**.

Select location with cursor keys **▲**, **▼**.

Confirm with key **OK**.

Readings display

NONAME		012 01/03	
23.8	24.9	21.00	
FT	°C	AmbT	°C O2 %
-----	-----	9.3	
Drgh mbar	Spd m/s	Volt V	
PStart	Zoom	v On	Print

OK

Box selection window

NONAME		012 01/01	
001 Control Unit			
*012 Testo t35: Meas.			
		ESC Change	

◀

NONAME		012 01/03	
+ ▢ Loc 1			
□□ NONAME			
		ESC Change	

▲

▼

Selecting a location

NONAME		012 01/03	
+ ▢ Loc 1			
□□ NONAME			
		ESC Change	

OK

Readings display

2. Description of the applications

2.4 Spot measurement of flue gas with base system – Control Unit 2.4.9 Changing the display

Connect analyser box and Control Unit; switch on Control Unit

with – **Device** – **View** –

menu display follows.

Assign the reading space with cursor keys.

Open window “**Parameter**”,
Unit, **Insert**, **Delete**”
with **OK** and activate the
“Parameter” menu.

Note:

“Insert” menu

Parameters can be inserted at any
desired parameter space. The existing
values are shifted by one space.

“Delete” menu

Delete selected parameters

Select parameter with “up” and
“down” keys and confirm with “OK”.

Automatic return to “Unit” menu.

Select unit with cursor keys , .

The new parameter is accepted with
the **OK** key.

Return to readings display with
function key “End”.

Readings display

NONAME		012 01/03	
23.8	24.9	21.00	
FT °C	AmbT °C	O2	%
-----		9.3	
Drgh mbar	Spd m/s	Volt U	
PStart	Zoom	v On	Print

Main menu

Meas. prog. / Readings			
Memory	20.8	21.00	
Sensors	mbT	°C	%
Input			
Device	1.8	9.5	
Service	0.02		
Drgh mbar	Spd m/s	Volt U	
		ESC	OK

Select “Device”

Change Device settings			
Memory	20.8	21.00	
Sensors	mbT	°C	%
Input			
Device	1.8	9.5	
Service	0.02		
Drgh mbar	Spd m/s	Volt U	
		ESC	OK

Activate view

View			
View			21.00
Diagnostic			O2 %
Configuration			
Service	1.8	9.5	
Drgh mbar	Spd m/s	Volt U	
		ESC	OK

Display sequence

Displ. seq.		01/06	
FT	AmbT	O2	
°C	°C	%	
Drgh	Spd	Volt	
mbar	m/s	U	
		ESC	End

Display sequence

Parameter		01/06	
Parameter	bT	O2	
Unit		%	
Insert			
Delete			
Drgh	Spd	Volt	
mbar	m/s	U	
		ESC	OK

Parameter			
P	O2	er	bT
CO			O2
H2S			%
CxHy			
H2			
FT			
AmbT			
Drgh	Spd	Volt	
mbar	m/s	U	
		ESC	OK

Parameter			
P	O2	er	bT
CO			O2
H2S			%
CxHy			
H2			
FT			
AmbT			
Drgh	Spd	Volt	
mbar	m/s	U	
		ESC	OK

Select unit

ppm			
P	ppm	er	bT
%			O2
mgm ³			%
g/GJ			
mgKW			
Drgh	Spd	Volt	
mbar	m/s	U	
		ESC	OK

Accept the new parameter

Readings display

2. Description of the applications

2.4 Spot measurement of flue gas with base system – Control Unit

2.4.10 CO₂max/O₂ref

Connect analyser box and Control Unit; switch on Control Unit

with → **Input** → **O2ref/CO2**.

Select **O2ref** or **CO2 max** with cursor keys . Confirm with **OK** key.

With the cursor keys , select numbers in the numeric block and confirm with **OK** key.

= restore factory settings.

Accept entered value with the **End** function key.

Return to the readings display with **ESC**.

Readings display

NONAME		012/01/03	
23.8	24.9	21.00	
FT	°C	AmbT	°C O2 %
-----		9.3	
Drghmbar	Spd	m/s	Volt U
PStart	Zoom	v On	Print

Main menu

Meas. prog. / Readings			
Memory	20.8	21.00	
Sensors	mbT	°C	O2 %
Input	-----		
Device	1.8	9.5	
Service	0.02	-----	
Drghmbar	Spd	m/s	Volt U
		ESC	OK

Select "Input"

Calc. parameter input			
Memory	20.8	21.00	
Sensors	mbT	°C	O2 %
Input	-----		
Device	1.8	9.5	
Service	0.02	-----	
Drghmbar	Spd	m/s	Volt U
		ESC	OK

HT-Temp/spot no./ (oil)Ide			
Spot number / HCT	-----		
Fuel	-----		
O2ref/CO2max	-----		
Parameter	-----		
Dew point/ambient air	-----		
Drghmbar	Spd	m/s	Volt U
		ESC	OK

O2ref/O2max/Factors			
Spot number / HCT	-----		
Fuel	-----		
O2ref/CO2max	-----		
Parameter	-----		
Dew point/ambient air	-----		
Drghmbar	Spd	m/s	Volt U
		ESC	OK

Input O2ref.			
O2ref.	r/ HCT		
CO2max.	-----		
Parameter	-----		
Dew point/ambient air	-----		
Drghmbar	Spd	m/s	Volt U
		ESC	OK

O2ref. / light oil			
+0.0	+3.0	+25.0	
Min	1	2	3
	4	5	6
	7	8	9
	.	0	±
	+ _		
	←	Curr.	End

Select numeral and confirm

O2ref. / light oil			
+0.0	+3.0	+25.0	
Min	1	2	3
	4	5	6
	7	8	9
	.	0	±
	+4. _		
	←	Curr.	End

Input CO2max.			
O2ref.	r/ HCT		
CO2max.	-----		
Parameter	-----		
Dew point/ambient air	-----		
Drghmbar	Spd	m/s	Volt U
		ESC	OK

3 x **ESC**

 Readings display

2. Description of the applications

2.4 Spot measurement of flue gas with base system – Control Unit 2.4.11 HC on/off

Connect analyser box and Control Unit; switch on Control Unit

with  → **SENSORS** → **HC On** / **HC Off**.

Select readings window with cursor keys   → **HC On** / **HC Off**.

Confirm with the **OK** key.

Return to readings display with **ESC**.

The selection or **HC Off** is retained even after the instrument is switched off.

Note

If **HC On** is activated, a zeroing phase automatically takes place. Zero instrument again after 3 min (better 10 min.) (function button **Zero**) or switch analyser on/off.

Note

The HC sensor switches off automatically at an O2 level of <2% (protection function).

Readings display

NONAME		012/01/03	
23.8	24.9	21.00	
FT °C	AmbT °C	O2 %	∞
-----		9.3	
Drghmbar	Spd m/s	Volt U	
PStart	Zoom	v On	Print

Main menu

Meas. prog. / Readings			
Memory	20.8	21.00	
Sensors	mbT °C	O2 %	∞
Input	1.8		9.5
Device	Drghmbar	Spd m/s	Volt U
Service	0.02		
		ESC	OK

Select sensors

Sensor settings			
Memory	20.8	21.00	
Sensors	mbT °C	O2 %	∞
Input	1.8		9.4
Device	Drghmbar	Spd m/s	Volt U
Service	0.02		
		ESC	OK

OK

Recalibration			
Recal.	21.00		
NO2 addition			
HC On/Off			
Print cal. data			
Service	0.02	1.8	9.4
Drghmbar	Spd m/s	Volt U	
		ESC	OK

Select HC On/Off

HC On/Off			
Recal.	21.00		
NO2 addition			
HC On/Off			
Print cal. data			
Service	0.02	1.8	9.4
Drghmbar	Spd m/s	Volt U	
		ESC	OK

OK

HC Off			
HC On	21.00		
HC Off			
ion			
Print cal. data			
Service	0.02	1.8	9.4
Drghmbar	Spd m/s	Volt U	
		ESC	OK

OK

End

2 x



Readings display

2. Description of the applications

2.4 Spot measurement of flue gas with base system – Control Unit 2.4.12 Switching off CO, NO, NO₂, SO₂, HC

Connect analyser box and Control Unit; switch on Control Unit

with → **Service** → **Switch-off**.

Select menu **CO**, **NO**, **NO₂**, **SO₂** or **HC** with key , . Confirm with the **OK** key.

With the cursor keys , , , select numbers in the numeric block and confirm with the **OK** key.

Switch-off limits

Gas	Default	Upper limit
CO _{H₂}	5000	10000
CO _{H₂low}	500	1000
NO	3750	5000
NO _{low}	375	500
NO ₂	600	1100
SO ₂	3750	5000
H ₂ S	225	500
HC	40000	40000

Caution!

In the case of some gases, the upper limit for the switch-off limits exceeds the overload limit.

Accept entered value with function key **End**.

Return to readings display with **ESC**.

Readings display

Main menu

Select "Service"

Op. values

Select "Switch-off"

Activate parameter

Select numeral and confirm

Readings display

2. Description of applications

2.4 Spotmessung Abgas mit Basissystem – Control Unit

2.4.13 Hiding spot number, heat carrier temperature and oil derivative in the printout

Connect analyser box and control unit, switch on control unit

Activate  -> **Device** ->
Configuration ->
Spot number/HCT menu

Confirm with **OK**.

The following menu items appear

Menu on / **Menu off**

The currently set configuration is selected. The menus are set at "On" in the factory.

Select ,  button and confirm with **OK**.

Press **ESC** to return to readings display.

Only the selected parameters are printed.

Note

The menu can be interrupted with the **ESC** button. The old setting is retained and the menu is closed.

Readings display

Loc 1		001/01/01	
61.2	23.2	0.66	
%	°C	m/s	
Max	Min	Mean	Search

Main menu

Meas. prog. / Readings		23.2		0.66	
Memory		°C		m/s	
Probe					
Input					
Device					
Service					
		ESC		OK	

Select device

Change Device settings		23.2		0.66	
Memory		°C		m/s	
Probe					
Input					
Device					
Service					
		ESC		OK	

OK

View		21.00		02	
View					
Diagnostic					
Configuration					
Service				9.7	
Drgh	mbar	Spd	m/s	Volt	U
		ESC		OK	

Select configuration

Configuration		21.00		02	
View					
Diagnostic					
Configuration					
Service				9.7	
Drgh	mbar	Spd	m/s	Volt	U
		ESC		OK	

Spot number/HCT menu

OK

Spot number/HCT menu		23.2		0.66	
Spot number/HCT menu		°C		m/s	
Configuration					
Service				9.7	
Drgh	mbar	Spd	m/s	Volt	U
		ESC		OK	

Menu On/Off

OK

menu on		23.2		0.66	
S menu on		°C		m/s	
HCT menu					
Cor menu off					
Service				9.7	
Drgh	mbar	Spd	m/s	Volt	U
		ESC		OK	

Select menu

menu off		23.2		0.66	
S menu on		°C		m/s	
HCT menu					
Cor menu off					
Service				9.7	
Drgh	mbar	Spd	m/s	Volt	U
		ESC		OK	

OK

ESC

3 x



Readings display

2.8 Long-term measurement of HVAC with the Control Unit



2. Description of the applications

2.8 Long-term measurement of HVAC with the Control Unit

Requirements

The Control Unit is equipped with a probe socket to which a large number of different HVAC probes can be connected. An example of spot measurements and all important steps of operation are described in chapter 2.1. Beyond the simple display of readings, the Control Unit provides a means of continuously recording all readings of a probe and the integrated pressure sensor over a longer period.

Operation on the basis of an example measuring task

Measurement of the CO₂ concentration in an office during a workday in a partitioned office room.

Connect the probe

The CO₂ probe is connected to the probe socket of the Control Unit by the plug-in head cable. The use of a mains adapter is strongly recommended for long-term measurements.

Caution!

Probes are only detected by the Control Unit when connected before switching on.

Switch on the Control Unit

After the Control Unit has been switched on () and a brief initialisation phase has elapsed, the readings of the connected probe and of the pressure sensor installed in the Control Unit are displayed.

Assigning readings to a location and storing

The current readings can be stored in the memory of the Control Unit at any time by pressing function key **Mem.**. To maintain clarity in large volumes of data, each reading is always stored under a location. The current location is always displayed in the top line of the display.

Entering a new location

The location menu is opened by pressing the **OK** and **Left** keys. Memory management makes it possible to consolidate several locations in a directory in a manner similar to the data management of PC operating systems.

Change and **New folder** activate the text input menu.

Select the desired letters with **Up**, **Down**, **Left**, **Right** and confirm with **OK**.

End branches to the location menu.

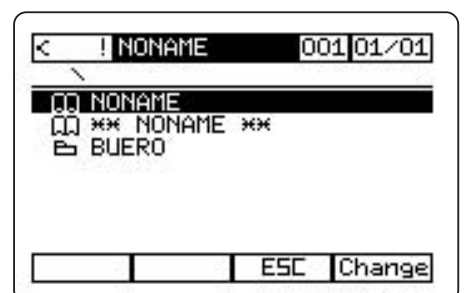
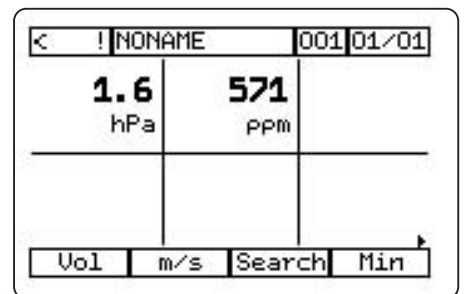

Hint

The next higher directory level can be accessed with **ESC**.

2. Description of the applications

2.8 Long-term measurement of HVAC with the Control Unit

With **▲ ▼** → **OK**, the desired location or a folder, which can contain further locations, can be selected. The newly created folder **Room** is selected here.

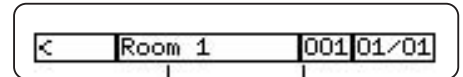

After entering a new location with **Change** → **New location** → **Room 1** → **End**, confirm it with **OK**.

This is then indicated in the top bar of the display.

Entering a measuring program

A measuring program is created to record the CO₂ values in the office over a longer period:

Memory → **Program** activates the program menu. Selecting menu item **Start** initiates an automatic query of all important parameters for a measuring program.

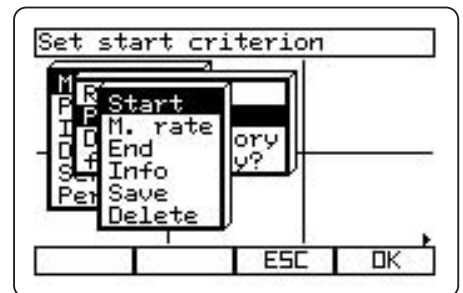

Manual: the measuring program can be started at any desired time using the function key “Start”.

Date/Time: the measuring program is started at a pre-programmed time.

Overshoot/Shortfall: the measuring program is started in dependency on desired events (readings overshoot/shortfall a specified value).

In this case: “Manual” is selected. **OK** automatically activates the “Measuring rate” menu:

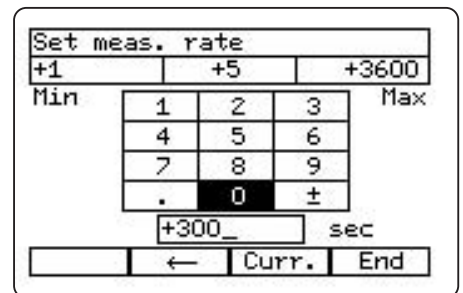

The measuring rate is entered in seconds (in this case, 5 min. = 300 sec.), then **End**.

The stop menu of the measuring program is automatically activated.

Memory full: Reading recording stops when the reading memory is full.

Number of values: a desired number of values is recorded.

Date/Time: Reading recording stops at a desired time.

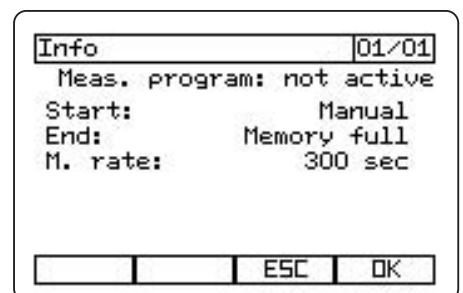

Note

A running measuring program can be stopped at any time with function key **Stop**. In this case, the stop condition **Memory full** is recommended.

Finally, an overview of the entered measuring program is displayed.

The reading menu is activated with **OK**.

Important: No measuring program has been started at this time. The measuring program only starts when the start condition is fulfilled. With the **Manual** option selected here, function key **Start** must be pressed to start the program.

2. Description of the applications





2.8 Long-term measurement of HVAC with the Control Unit

Reading out data from memory and printing with the integrated printer

 -> **Memory** -> **Read-out**

displays the reading files stored for the currently active location. Several data records can be stored, which can be explicitly identified by the starting time of the measuring program.

When a data record is selected, the following overview appears.

The individual data records can be selected with  , during which each respective time of the measurement recording is indicated in the top line of the display. If more than 3 parameters are to be recorded simultaneously, these can be displayed with  .

Print generates a print-out of the data record on the integrated printer, specifying the starting time, the stopped time and the time of printing.

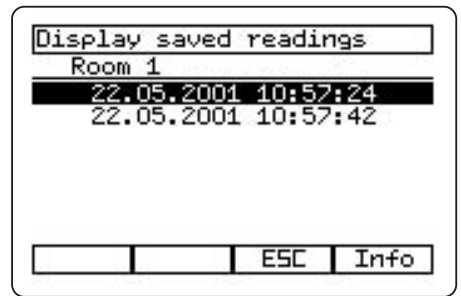

Overview of readings

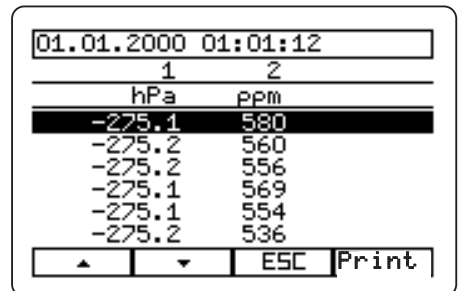

Printing the readings

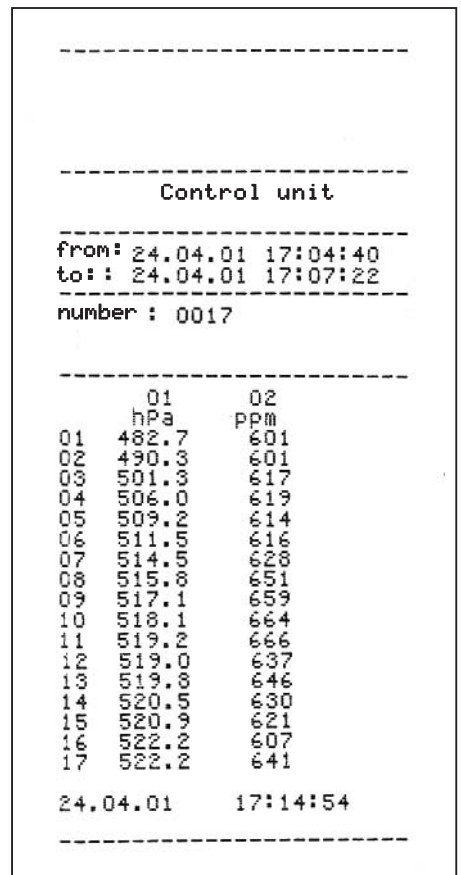

2.9 Long-term measurement of HVAC with the Control Unit and logger

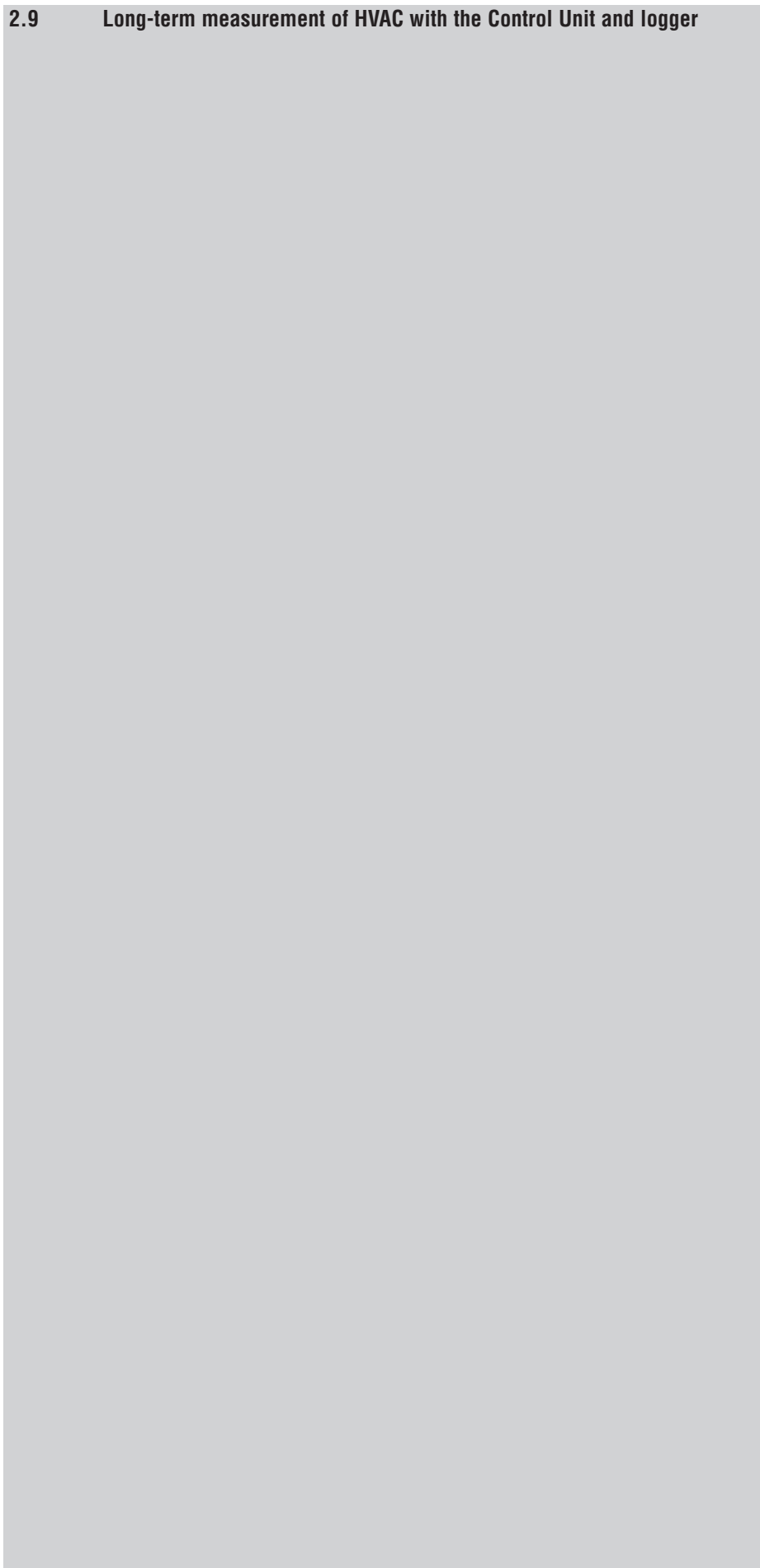

2. Description of the applications

2.9 Long-term measurement of HVAC with the Control Unit and logger

Operation on the basis of an example measuring task

Recording of temperature, humidity and CO₂ over a longer period in a partitioned office room

Important preliminary consideration: Where are which readings stored?

The testo 454 Control Unit and logger system has two means of storing data:

- Memory for 250,000 readings in the Control Unit
- Memory for 250,000 readings in the testo 454 logger

However: Readings can only be stored where the associated probe is connected.

- Control Unit: 1 probe socket + integrated pressure sensor
- testo 454 logger: 4 probe sockets

For this reason, it is advisable for this measuring task to connect both probes (CO₂ probe and HVAC probe for temperature and humidity) to the testo 454 logger. This simplifies data storage and evaluation.

- **Connect probes to Control Unit and logger**
- **Switch on the Control Unit**
- **Use the probe socket of the Control Unit or logger**

These items are described in detail in chapter 2.2, "Measuring and storing with the Control Unit and a logger".

Assigning readings to a location and storing

The current readings can be stored in the memory of the testo 454 logger at any time by pressing function key **Mem.**. To maintain clarity in large volumes of data, each reading is always stored under a location. The current location is always shown in the top line of the display.

Entering a new location

The location menu is opened by pressing the **OK** and **Left** keys. Memory management makes it possible to consolidate several locations in a directory in a manner similar to the data management of PC operating systems.

Change and **New folder** activate the text input menu.

Select the desired letters with **Up**, **Down**, **Left**, **Right** and confirm with **OK**.

Change branches to the location menu.

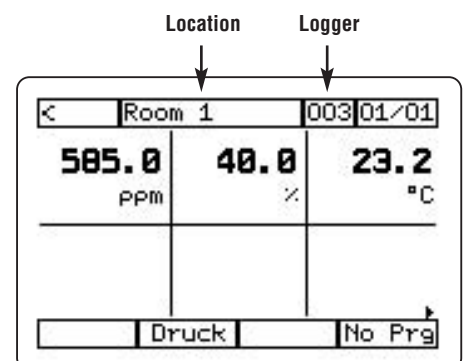

Text input menu



Location menu

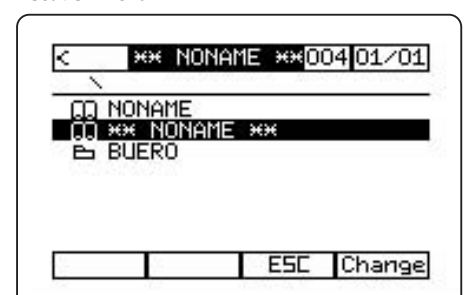

2. Description of the applications

2.9 Long-term measurement of HVAC with the Control Unit and logger

With **▲ ▼** → **OK**, the desired location or a folder, which can contain further locations, can be selected. The newly created folder **Room** is selected here.

After entering a new location, **Change** → **New location** → **Room** → **End**, confirm by pressing **OK**.

This is then indicated in the top bar of the display.

Entering a measuring program

A measuring program is created to record the CO₂, temperature and humidity values in the office over a longer period:

Memory → **Program** → **Start** activates the program menu of the testo 454 logger. Selecting menu item **Start** activates an automatic query of all important parameters for the measuring program.

Manual: The measuring program can be started at any desired time using the function key "Start".

Date/Time: The measuring program is started at a pre-programmed time.

Overshoot/Shortfall: The measuring program is started in dependency on desired events (readings overshoot/shortfall a specified value).

In this case: Manual selected. **OK** automatically activates the Measuring rate menu: The measuring rate is entered in seconds (in this case, 5 min. = 300 sec.), then **End**.

The stop menu of the measuring program is automatically activated.

Memory full: Reading recording stops when the reading memory is full.

Number of values: A desired number of readings is recorded.

Date/time: Reading recording stops at a desired time.

Hint

The next higher directory level can be accessed with **ESC**.

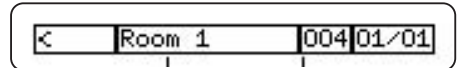

Logger program menu

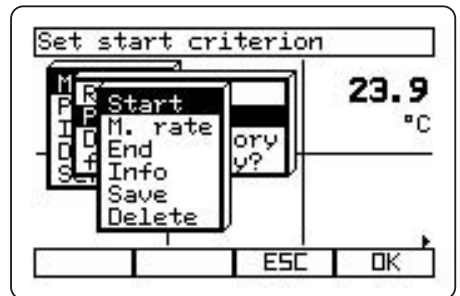

Measuring rate menu

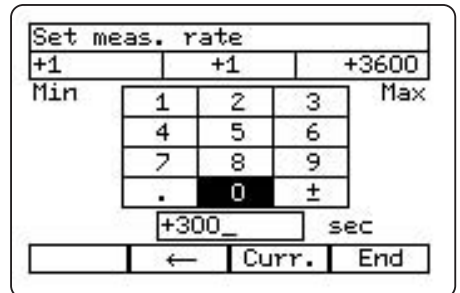

Overview of the entered measuring program

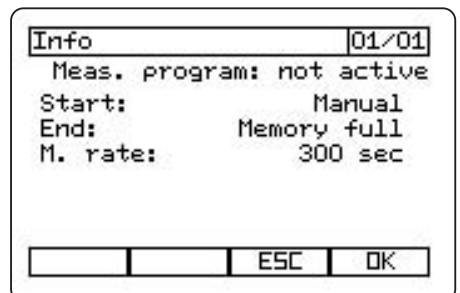

Hint

The next higher directory level can be accessed with **ESC**.

Note

A running measuring program can be stopped at any time with function key **STOP**.

In this case, the stop condition **Memory full** is recommended.

Finally, an overview of the entered measuring program is displayed. The reading menu is activated by pressing **OK**.

Important!

No measuring program has been started at this time. The measuring program only starts when the start condition is fulfilled.

With the "manual" option selected here, function key "Start" must be pressed to start the program.

2. Description of the applications





2.9 Long-term measurement of HVAC with the Control Unit and logger

Reading data from memory and printing with the integrated printer

 -> **Memory** -> **Read-out**

displays the reading files stored for the currently active location. Several data records can be stored, which can be explicitly identified by the starting time of the measuring program.

When a data record is selected, the following overview appears.

The individual data records can be selected with  , during which each respective time of the measurement recording is indicated in the top line of the display. If more than 3 parameters are to be recorded simultaneously, these can be displayed with  .

Print generates a printout of the data record on the integrated printer, specifying the starting time, the stopped time and the time of printing.

Display of the reading files

Display saved readings	
Room 1	
22.05.2001 13:24:02	
22.05.2001 13:24:52	
ESC Info	

Overview of readings

17.05.2001 11:37:38		
1	2	3
ppm	%	°C
626.0	48.0	22.5
609.0	48.0	22.5
588.0	48.1	22.5
607.0	48.1	22.5
627.0	48.0	22.5
614.0	48.1	22.4
▲	▼	ESC Print

Printing the readings

```
-----  
  
-----  
Control unit  
-----  
from: 24.04.01 17:04:40  
to: 24.04.01 17:07:22  
-----  
number : 0017  
-----  
  
01 02  
hPa ppm  
01 482.7 601  
02 490.3 601  
03 501.3 617  
04 506.0 619  
05 509.2 614  
06 511.5 616  
07 514.5 628  
08 515.8 651  
09 517.1 659  
10 518.1 664  
11 519.2 666  
12 519.0 637  
13 519.8 646  
14 520.5 630  
15 520.9 621  
16 522.2 607  
17 522.2 641  
  
24.04.01 17:14:54  
-----
```

2.10 Long-term measurement of HVAC with PC plug-in card



2. Description of the applications

2.10 Long-term measurement of HVAC with PC plug-in card

Requirements

You have connected a data logger with connected HVAC probes through the plug-in card to the PC. The installation has been completed and the Comfort-Software has been started.

Operation

Initialisation

The bus is then initialised: after you have selected the bus icon and clicked on **Open** with the right mouse key, the instrument responds. Click on the device icon with the right mouse key to open the device menu.

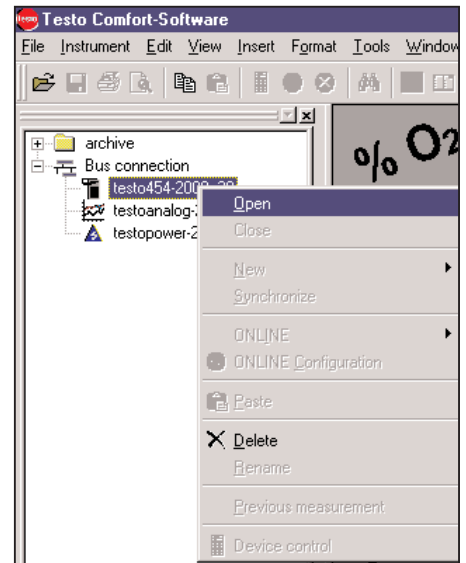

Device control

After opening the instrument, select item "Device control".

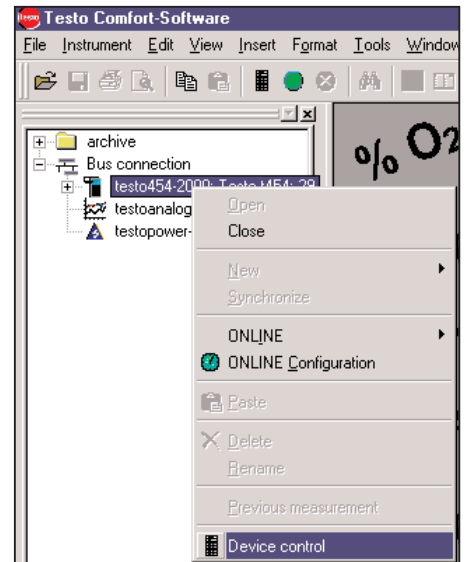

This opens the main window of the device control.

The first view provides general information about the instrument such as the serial number, software version and battery capacity as well as the number of records stored in memory and the memory capacity available for further measurements.

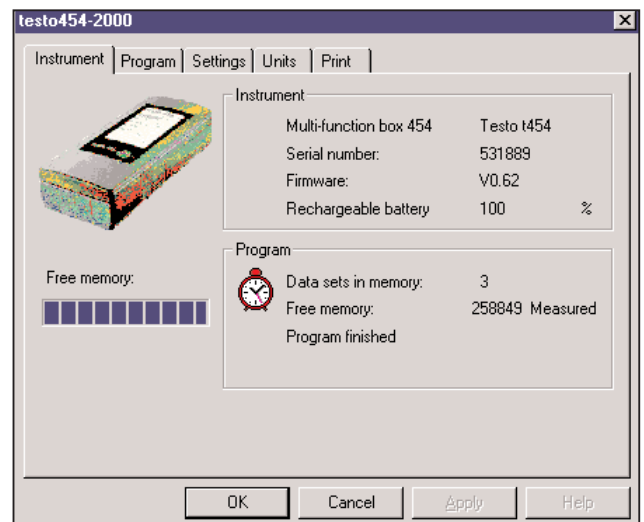

2. Description of the applications

2.10 Long-term measurement of HVAC with PC plug-in card

Note

Select the second register card **Program** to prepare and program long-term measurements.

You can define the start and stop criteria for subsequent, automatic measurements here. **Date/Time** starts and stops the program at precise times. **PC-start (manual)** activates the separate start key at the bottom of this menu.

With “Start” and “Stop” using **Trigger**, the signals of the trigger line which can be connected to the logger are monitored. The program starts and stops when triggered by a rising or falling flank.

With **Channel trigger**, the selected measuring channel is monitored. The program then starts when a particular limit value is reached or no longer measured.

Further stop criteria are available: **No. of values** after which storing is to stop **until memory is full** or **Wrap-around memory** - in this, the first memory space is overwritten when the last has been used and the memory is constantly updated. The program then runs without stopping.

When **Data reduction** is activated, the data are only stored if significant changes occur. Equal readings, i.e. values which remain constant over a long period, are replaced by one representative value. This represents all values for this interval.

If only changes in the readings are of interest, this considerably reduces the volume of data to be evaluated.

The **Measuring rate**, i.e. the interval at which new values are measured, is programmable in units of seconds, minutes and hours. The smallest possible measuring rate depends on the number and type of the connected probes.

Assign a name to the measuring program in the **New location** box. It is easier to identify, process and archive the data at a later date by this name. Additional text can be entered under **Properties**, which describes the measurement in more detail.

When you have specified the start criterion, stop criterion and the location, store the measuring program in the logger by clicking **Apply**. This then waits for the defined start criterion to begin measuring.

When the measuring program has been automatically executed by the logger for which the logger must not necessarily remain connected to the databus, the logger must be re-activated on the bus. The records stored in the logger with the entered locations are displayed automatically. To read-out the data, click on the location or the record and drag the icon with the mouse from the archive section to the desktop to the right of it. The results of the long-term measurement are immediately displayed as a diagram or a table.

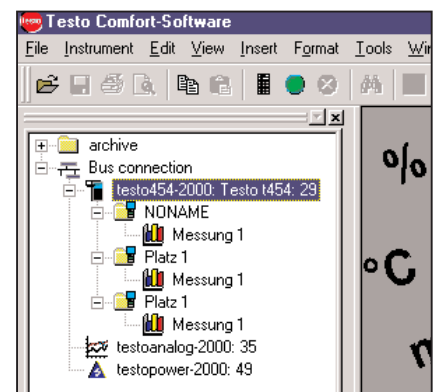
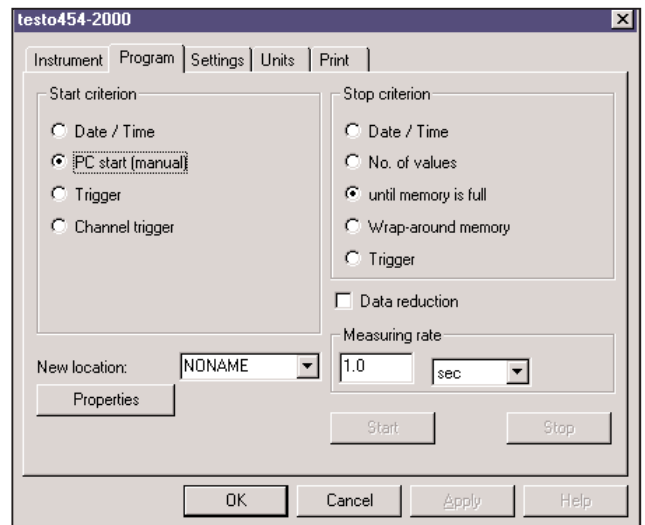

For further information, see chapter 1.8, Comsoft 3, example 1 and example 2.

2. Description of the applications

2.10 Long-term measurement of HVAC with PC plug-in card

Further settings in conjunction with long-term measurements and a data logger with HVAC probes

Settings provides detailed information on the connected probes and the channels combined with them. Diverse settings are possible depending on the sensor. Parameters can also be changed, which determine the behaviour of the entire logger. The probes connected to sockets 1 to 4 with the respective probe type and the associated serial number are displayed if connected. For multi-channel probes, the individual channels of each socket can be viewed.

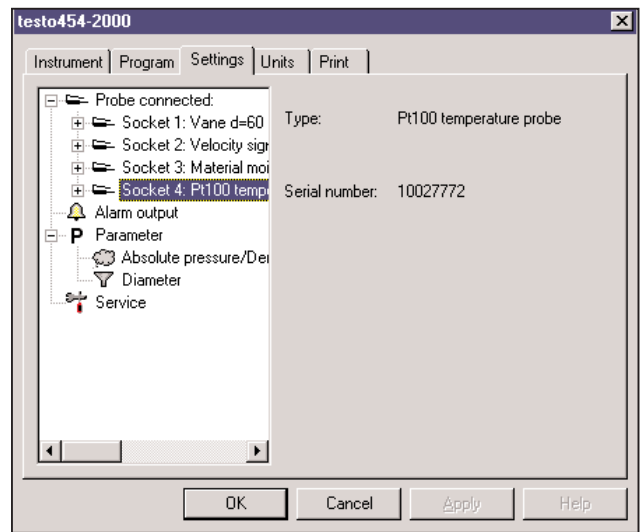

The following probe settings are possible:

Smoothing

This can be activated. The mean value of the number of entered readings is then calculated. The values in the “Online display” then no longer change as quickly. This is particularly advisable for measurements with pressure probes in conjunction with the 7-segment numeric display.

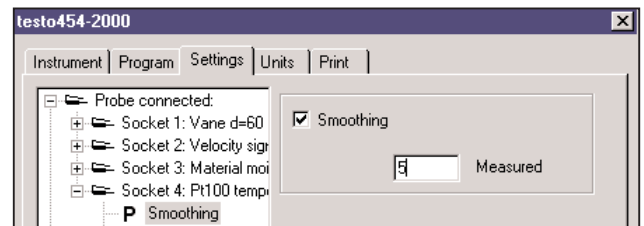

Surface addition

This addition takes account of the fact that a surface to be measured is cooled by contact with a temperature probe. The principle and extent of the cooling depends on the particular design of the probe. The correction relates to the difference between the surface and ambient temperatures, e.g. with a surface allowance of 4 % and a surface at 104 °C in an environment of 4 °C, the display of the temperature probe is corrected from 100 °C to 104 °C.

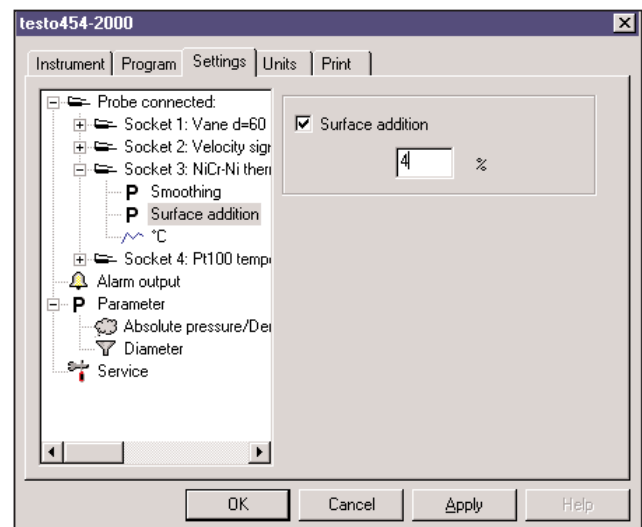

2. Description of the applications

2.10 Long-term measurement of HVAC with PC plug-in card

Selecting a unit, i.e. a probe channel

This makes it possible to enter a channel-specific name. Particularly with multi-channel measurements with the same units, this makes it easier to identify the channels correctly when viewing at a later date.

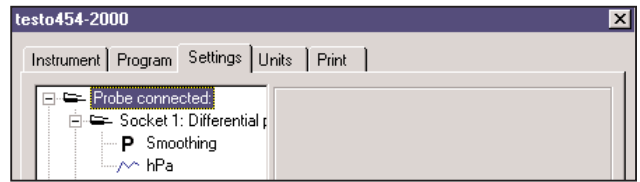

Scaling a current/voltage probe

If a current/voltage probe is connected instead of a probe automatically assigned to channels and physical units, this signal can be scaled and assigned to a physical value. Choose a unit in advance which represents the target value by selecting , as illustrated.

This is now to be scaled from a voltage signal as follows: 1.5 to 3.5 V represents 0 to 100 %RH:

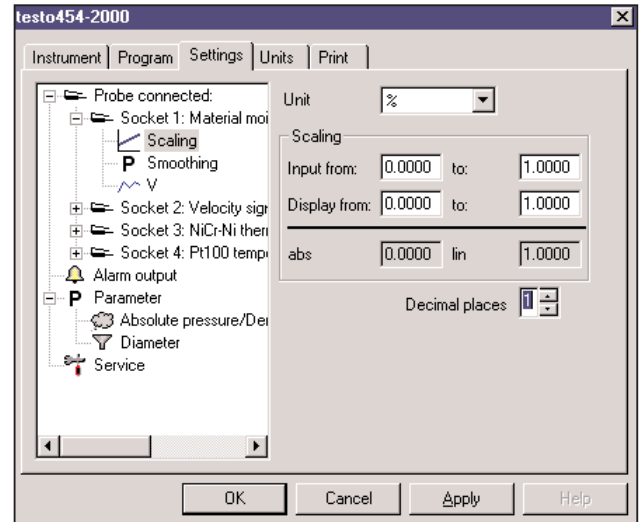

Alarm output

Each logger has its own integrated relay contact connected to the outside as a galvanically isolated changeover contact at the alarm/trigger socket. This can be accessed using line 0554.0012. The behaviour of this relay can be defined in item "Alarm output". When selected, a list of all available channels appears from which those can be selected which are to switch the alarm output when the entered upper and lower limits are infringed.

When entries are made for several channels in this list, the alarm contact closes when one of the specified channels infringes the entered limits.

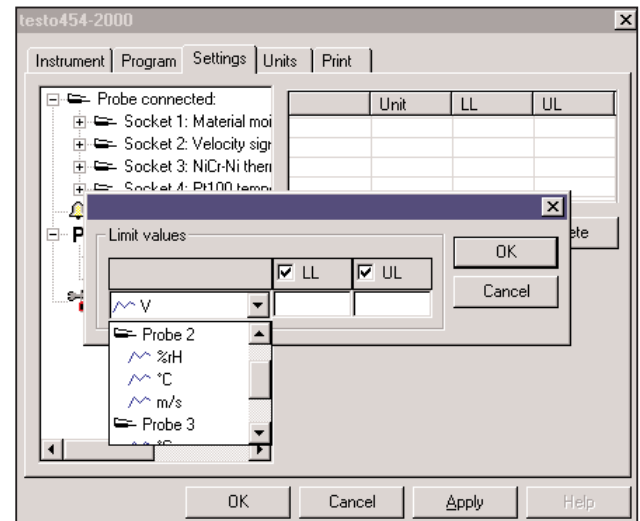

2. Description of the applications

2.10 Long-term measurement of HVAC with PC plug-in card

Parameters

Parameters can be entered here which can have effects on the results of the individual channels of several units and which are used to calculate these.

For example, the absolute pressure entered for **Parameter "Pressure"** affects the connected thermal flow rate probes and CO₂ probes and compensates their signals dependent upon the absolute pressure.

If differential pressure probes are connected and automatic m/s calculation is active, the density entered under **Parameter "Pressure"** has an influence on the air velocity calculated from the pitot tube pressure. The density itself is determined by calculation from the entered values of temperature, humidity and absolute pressure.

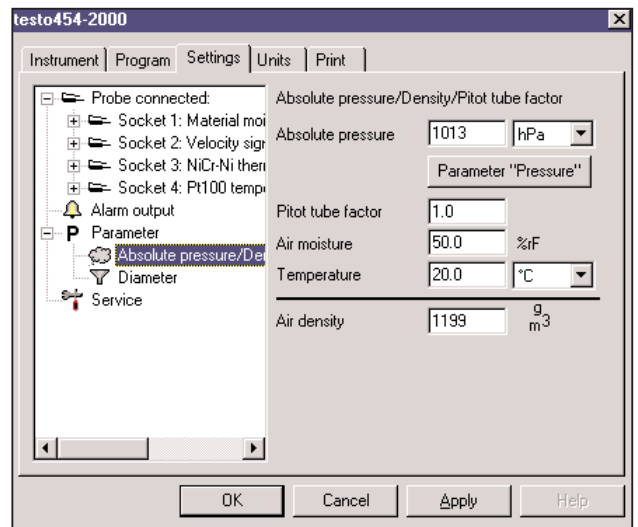

The absolute pressure can also be determined by entering the local altitude, the barometric air pressure at this altitude and an additional differential pressure or underpressure in the channel.

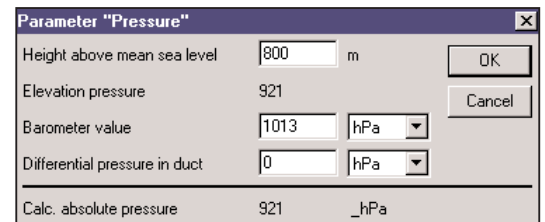

If flow rate probes are connected, the cross-section entered under **Parameter** has an equal effect on all m/s channels. Each m/s reading is converted by the entered cross-section. A further channel with a volume flow unit is opened and assigned to the values calculated in this manner.

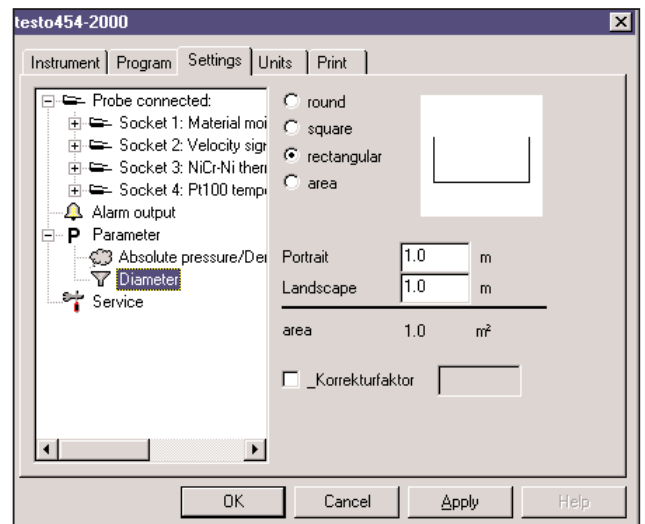

2. Description of the applications

2.10 Long-term measurement of HVAC with PC plug-in card

Service

With this item, you can erase the internal memory of the logger or conduct a general reset to the factory settings. For example, this sets all probe-related input parameters to the factory values. After changing a probe, you can instruct the logger to detect the probes, which otherwise occurs only when the system is switched on. You can enter a specific short text in the Testo logger designations **Name**. With the **Check instrument** button, special error detection routines are executed. You will then receive any error messages and information on the status of the logger.

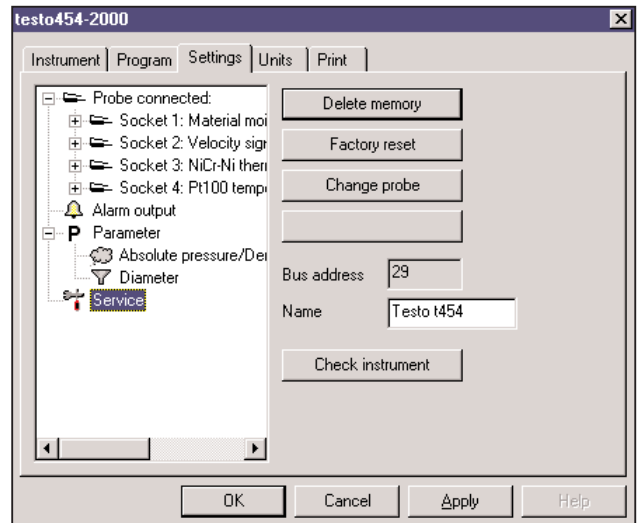

Units

Specify the units for your logger here, e.g. the temperature unit °C or °F, the flow rate m/s or ft/min etc.

If humidity probes are connected, you can enter a separately calculated absolute humidity value. This value is then displayed additionally as a further channel in g/m, g/kg, °Ctp etc in addition to the relative humidity.

A volume velocity activated here activates an additional volume velocity channel for each m/s channel and calculates these values automatically from the m/s and the area entered under **Parameter**.

The activated flow velocity creates a further channel for each connected differential pressure probe. The m/s value is then calculated from the pressure values and the density entered under **Parameter**.

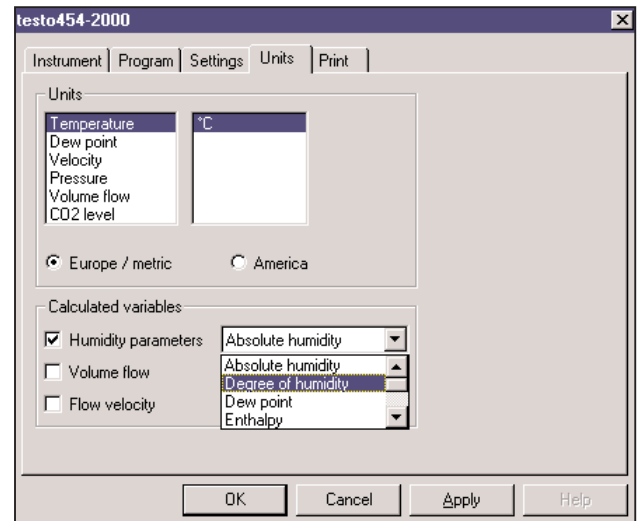

Print

Each logger is delivered with a cover panel which can be clipped onto the logger. A card can be placed behind the view port of this panel, which can be typed and printed here by simple means.

This is intended to help you in setting up, interconnecting and fitting the probes on-site to plug the pre-defined probes into the correct socket of the correct logger. This is the only way to ensure that the entered parameters for the alarm, limits, allowances, calculations etc. operate in an orderly manner and as intended.

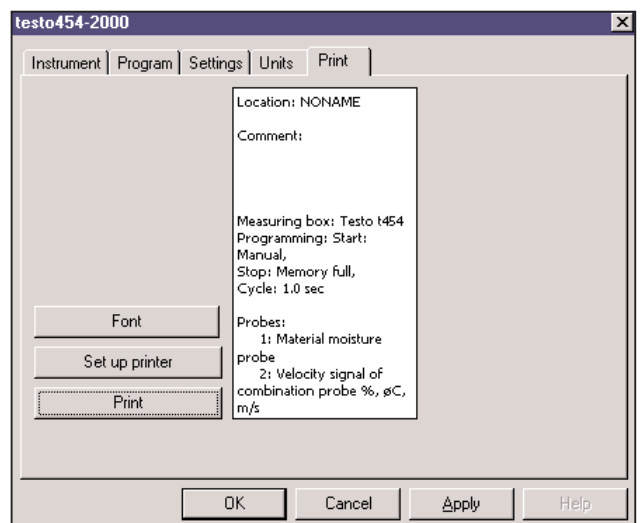

2.12 Long-term measurement of several boxes with PC plug-in card



2. Description of the applications

2.12 Long-term measurement of several boxes with PC plug-in card

Note

Concurrent measurements with several loggers on the bus, in which data is stored in the decentralised memory of each individual logger, operates in principle equivalently with data recording using a single instrument.

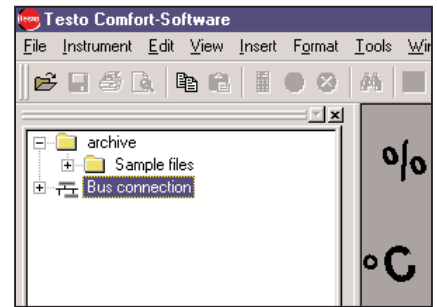

Operation

Initialisation

First, the bus must again be initialised. After starting the software, click on the bus icon, open the menu with the right mouse key and confirm by pressing **Open**. All connected loggers and the contents of their memory with the location name are then displayed.

Device control

With the menu item **Device control** in the menu of the device icon, you can erase the device memory in the register **Service** or, if sufficient memory space is available, store the data of a further measuring program in the device memory.

For this, open the register **Device control** in the **Measuring programs** to define the measurement. See also "Measurements with one logger only". After programming, either close the menu of the device icon or execute the **Synchronize** command. The logger is then programmed.

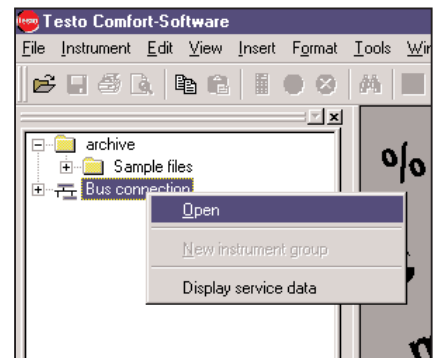

What should you observe?

Especially in operation with several loggers fully equipped with probes, probably also with probes which employ several channels simultaneously in the system, and also additionally activated channels which calculate further parameters, it is particularly important to consistently designate the used instruments, the connected probes and channels appropriately.

This may be conducted either according to the serial numbers of the devices, a proper name or simply the locations at which the loggers and probes are installed. When these designations have been made, it is far easier later to sort, evaluate and document data. For example, the table headers not only contain 10 times °C with the corresponding values, but also designations such as supply, return, circuit 1, circuit 2, wall, ceiling, floor etc.

It is also advisable to run all employed loggers throughout the same period at the same cycle rate. Otherwise, problems can occur when consolidating data in tables.

This is most simply achieved with the time/date criterion for starting and stopping. When the stored measuring programs have been executed, the memory of each logger contains a further record designated by the name entered under **Measuring programs**.

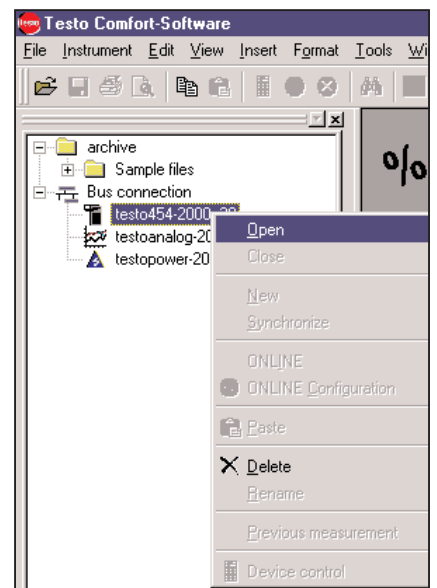

2. Description of the applications

2.12 Long-term measurement of several boxes with PC plug-in card

We recommend copying the memory contents or the desired records in advance from the instrument into the data area of the archive. The data is then more quickly available for later evaluation than when it is re-read from the instrument each time.

You can now display all channels of each location simultaneously as a diagram or table in one record. The channels of each logger can be selected. However, you can also mix the data of various loggers and consolidate these in a record. Such mixed data displays can also be stored. They then receive a newly designated view in the archive section.

Online measurement in multi-logger operation

As an alternative to decentralised data storage in the memory of the individual loggers, you can also conduct online measurements in multi-logger operation. This is of particular interest to link the individual channels of selected boxes into a new "virtual" instrument group.

In this way, you can assign various views to a running, multiple-channel system and thereby obtain in RAM and for the file later stored, only the readings pertaining to this view.

The optical appearance, the screen division with all parameters such as limits, colours etc. are also stored together with this view. Such a view can be reactivated when the software has been started in the same manner as an actually existing instrument. The data is then stored in a new record of the same view.

To create a view mixed from several channels of several boxes, click on the bus icon and execute the **New instrument group 1** command.

A list window then opens which contains all available loggers and the channels of the probes connected to them.

Make the desired selections from this list and give the selection a name, e.g. **Group 1**.

After confirming the selection with OK, you can treat the group as a new instrument. For online measurements, click on the group with the right mouse key and start the online measurement using **Online Start** or start the view directly using the green start button in the icon bar.

With the **Online configuration** command, you can determine in advance the measuring rate at which the data is taken into memory. Please observe that the full measuring rate of 1/sec cannot always be achieved, depending on the combination of loggers and probes.

After starting the online measurement, the table is displayed. It quickly becomes apparent that it would have been better to give one channel or another a more explicit designation.

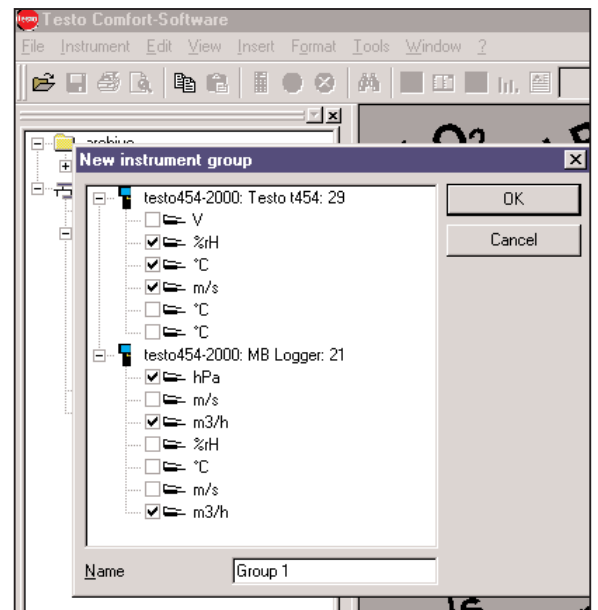
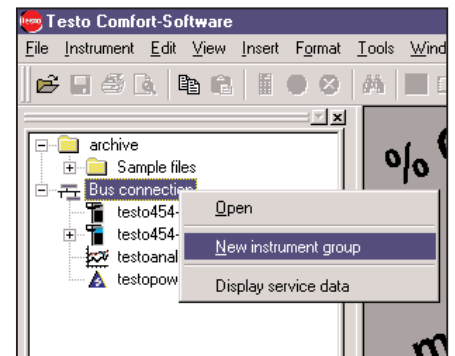

2. Description of the applications

2.12 Long-term measurement of several boxes with PC plug-in card

If you click with the “right mouse key” in the table field, you can further reduce the contents of the view to look more closely at individual channels or combinations of channels.

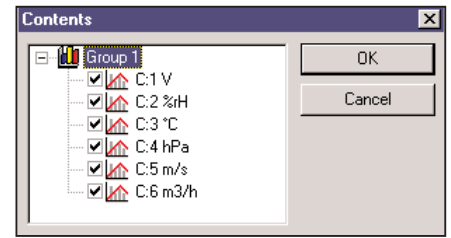

By activating the “diagram icon” in the icon bar, you will receive the online readings of the activated channels in a line diagram. It is also advisable here to include only the relevant curves in each view. This provides better clarity, particularly when several channels with different parameters and physical units are combined.

An appropriate combination of scales and colours is helpful.

These can be combined and simplified with **Tools**, **Settings**.

Group 1	Date	Time	V	%rH	°C
1	23/05/01	10:23:41	1.89	39.01	23.03
2	23/05/01	10:23:44	1.89	39.00	23.03
3	23/05/01	10:23:47	1.89	39.00	23.03
4	23/05/01	10:23:50	1.89	39.00	23.03
5	23/05/01	10:23:53	1.89	39.00	23.03
6	23/05/01	10:23:56	1.89	39.00	23.04
7	23/05/01	10:23:59	1.89	39.16	23.04
8	23/05/01	10:24:02	1.89	39.00	23.04
9	23/05/01	10:24:05	1.89	39.00	23.04
10	23/05/01	10:24:08	1.89	39.00	23.04

An appropriate designation of the channels is also important in this section.

For this, click on the individual curve and enter a name under menu item

Properties.

The number of decimal places is of particular interest for the numeric display.

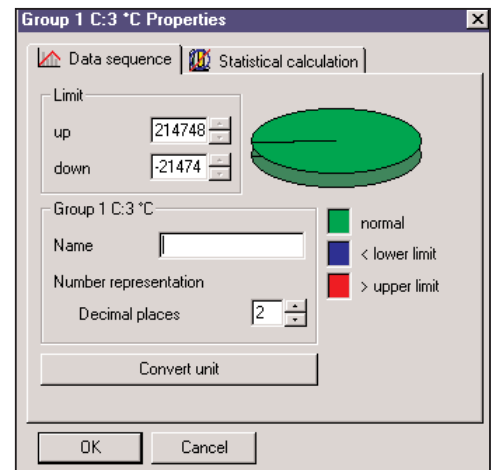

2.12 Long-term measurement of several boxes with PC plug-in card

To activate the numeric display, click in the icon bar on the

7 segment digit symbol.

You will then receive all channels in the same display as for the installation display. If you click with the right mouse key in the unused, black area, you can insert a background image as well as a different background colour in place of the simple black background.

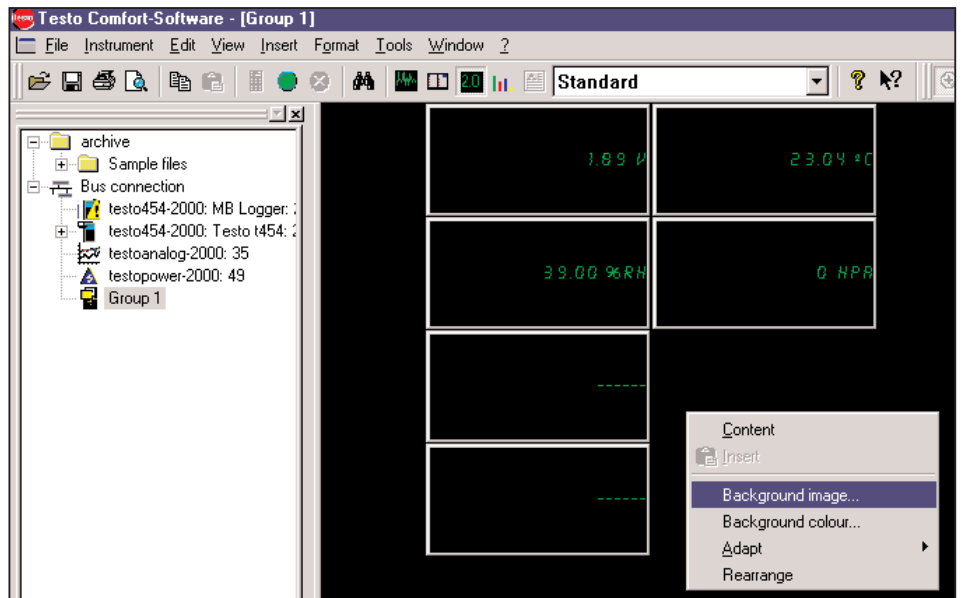

For improved visualisation of the readings, this may be an image of the measuring system. It is important that the image must be available as a bitmap in ".bmp" format.

The image can be adapted to avoid problems at the edges. In

Adapt, select either **Cinemascope** or **Fills image**.



2. Description of the applications

2.12 Long-term measurement of several boxes with PC plug-in card

If you click with the right mouse button on a framed display field, this can be further edited.

It is possible to activate or remove the frame of the display, to display the values transparently against the background or in an opaque coloured box, the colour of which can be chosen by the background colour.

With **Pattern**, you can select the colour of the displayed reading. The designated name of the channel is displayed as the header. You can also re-enter this here.

Activating **Min/Max** or **Mean** shows additional statistical information on this channel since online measurement was started.



If you move the mouse cursor to the frame of the display, you can drag the size of the display or its position against the background image.

Finally, enter the main menu with **View** and activate **Fullscreen**. You will then see the background image and the readings on the whole screen.

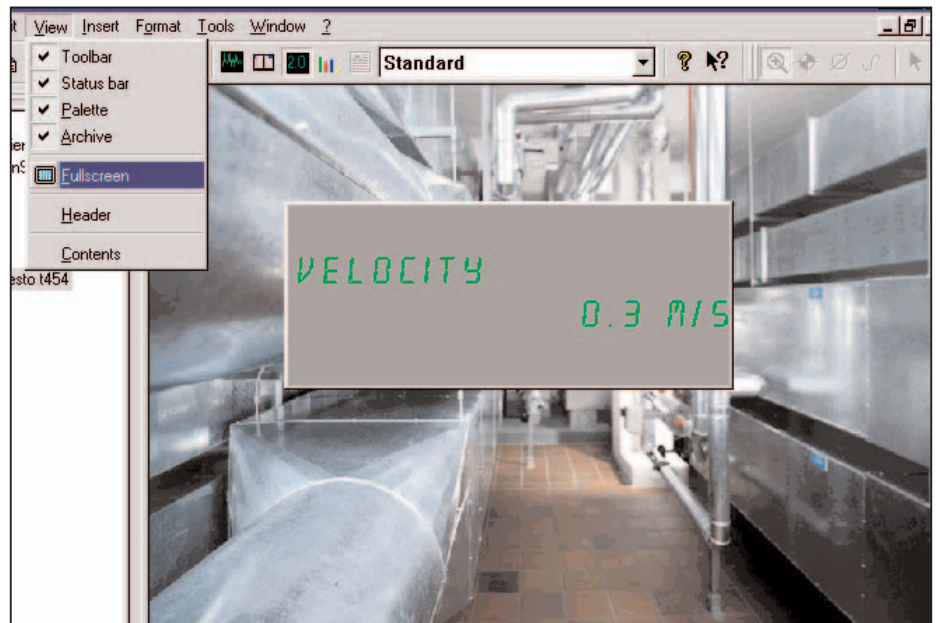

2.13 Long-term measurement of flue gas with the base system – Control Unit

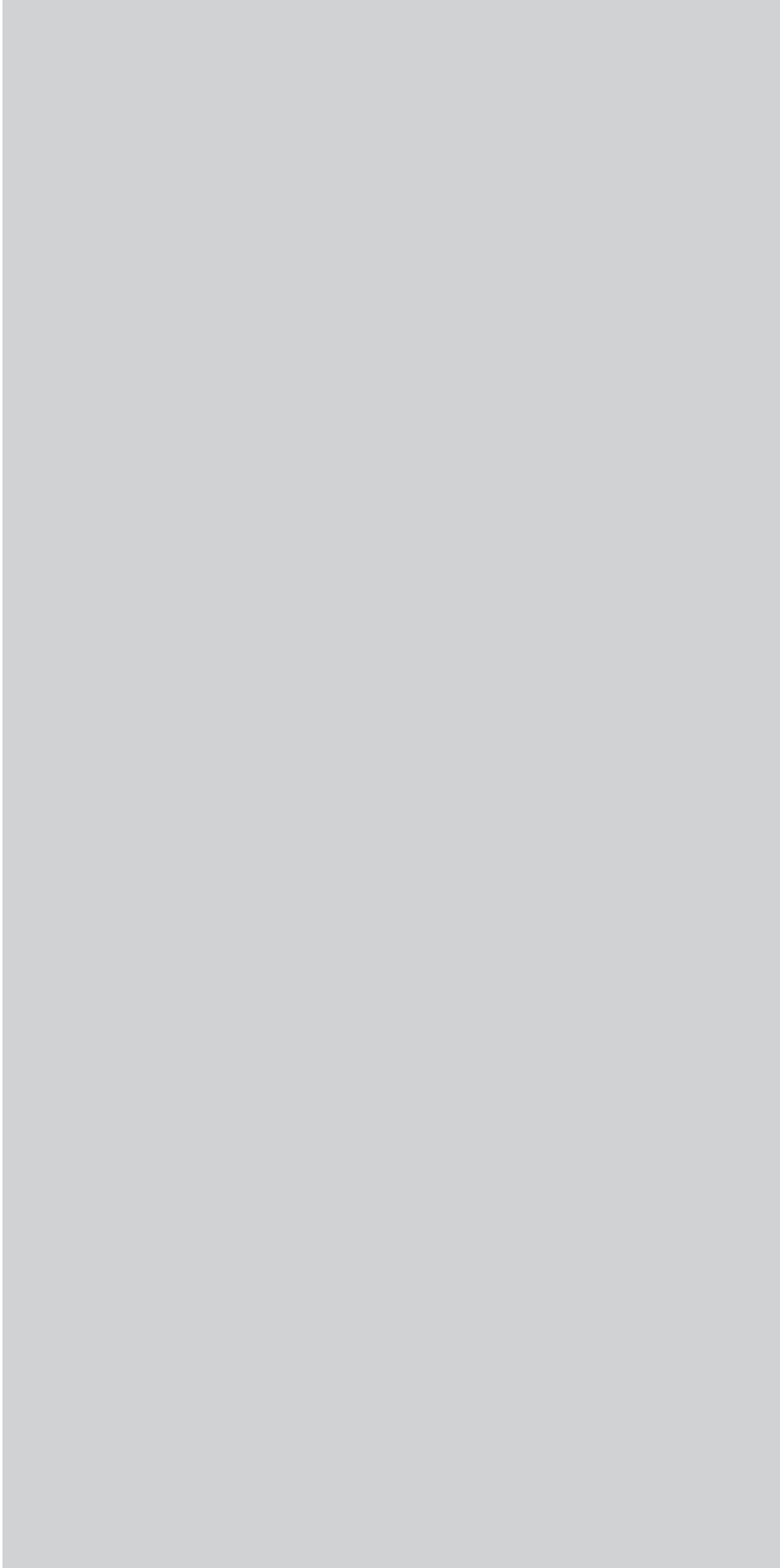

2. Description of the applications

2.13 Long-term measurement of flue gas with the base system – Control Unit

Operation on the basis of an example measuring task:

Long-term measurement over several hours on an industrial furnace with cycles of 10 min. measurement, 5 min. rinsing with fresh air, values stored every 15 sec.

Important preliminary consideration: Where are which readings stored?

The Control Unit system and the testo 350 have 2 means of storing:

- Memory for 250.000 readings in the Control Unit
- Memory for 250.000 readings in the analyser box

However: Readings can only be stored where the associated probe is connected.

- Control Unit: 1 probe socket + integrated pressure sensor
- testo 350 M/XL analyser box: 2 temperature probe sockets + integrated pressure sensor + direct and calculated parameters (dependent on the equipping).

- **Connect the Control Unit, analyser box and flue gas probe**
- **Switch on the Control Unit**

These items are described in detail in chapter 2.4, "Spot measurement of flue gas with the Control Unit".

Programming the analyser

Assign function button with "Start"

Main menu **Memory** → **Program** → **OK** → Enter values as per sample measurement job and confirm with **OK**.

Press the **Start** function button once you return to measurement menu. The **⏏** symbol in the top display bar shows which program is currently running.

Note

It is not possible to carry out any adjustments on the instrument while the program is activated.

Measurement phase

Can be interrupted with **Stop**.

Note

The measurement program remains activated even after **Stop** is activated or the instrument is switched off (indicated by **⏏** symbol).

Deleting analyser programming

Data is deleted in **Memory** → **Program** → **OK** → **Delete**.

Note:

For long-term measurements, the gas sensors require phases of fresh air to regenerate in dependency on the concentration and measuring duration. For guide values, see Chap. "Instrumentation notes"

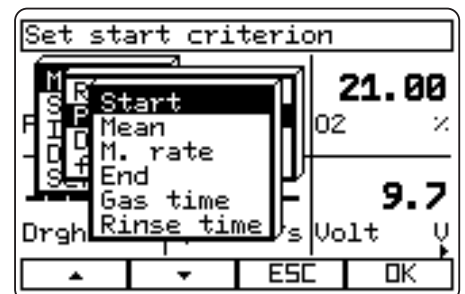

2. Description of the applications

2.13 Long-term measurement of flue gas with the base system – Control Unit

Measuring program

In the main menu: **Memory** → **Program** → **OK**

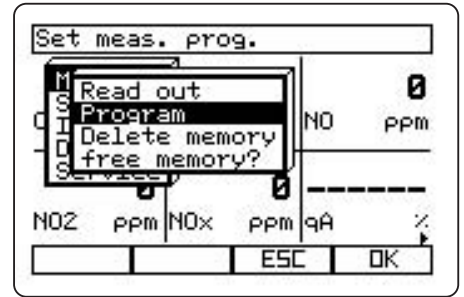

4 Start criteria

Manual: On a keystroke in the measuring menu (function key **START**)

Date/Time: Beginning of measurement at the selected date/selected time

Trigger: If the trigger input option is fitted (testo 350 XL only)

Trigger input:

The trigger input can be used as a criterion to either start or stop measuring programs.

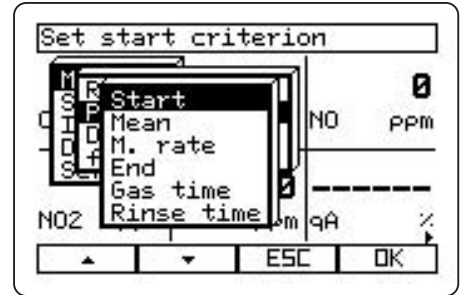

The following parameters can be adjusted for the trigger input:

- The measuring program is started when a rising edge is detected in the trigger signal. The program is also stopped by a rising edge.
- The measuring program is started when a falling edge is detected in the trigger signal. The program is also stopped by a falling edge.
- With level-dependent trigger signals, the data recording proceeds at the adjusted measuring rate as long as the trigger signal is active.

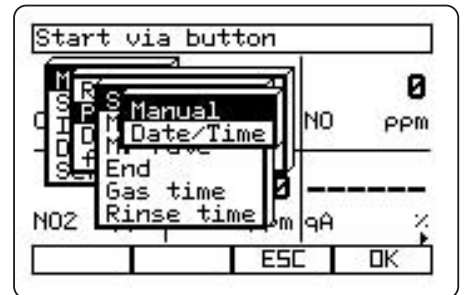

Possible modes in the measuring program:

- Measuring program is running
- Measuring program is activated
- Measuring program is inactivated, saved
- Measuring program deleted

2. Description of the applications

2.13 Long-term measurement of flue gas with the base system – Control Unit

Mean value

With mean value Yes only mean values will be saved:

Example of mean values

One mean value per parameter should be saved every 10 minutes. Input of measuring rate 600 s (= 10 min). The instrument measures every second and calculates the mean value every 10 minutes which is then saved.

Mean of mean values

The analyser saves a mean of all the mean values. It is highlighted by a * when the readings are called up of the memory. The mean value is the first value to appear on the printout.

Measuring rate

If Mean → yes is activated, the measuring rate is the saving cycle of the mean values (see example)

Selecting the “End” criterion

Selecting the “Gas time” cycle (= flue gas measurement)

Note:

The pump is stopped when a threshold concentration is reached (e.g. $O_2 > 20.5\%$). Reason: lower wear and power consumption

Overview of a programmed long-term measurement

OK → Measuring program is accepted

Mean	
NO2	20.87
CO	02 %
CO2	
SO2	
NO	
NOx	
SOx	
Drgh	9.1
Gas time	
Rinse time	
ESC OK	

Set meas. rate			
1	1	3600	
Min	1	2	3 Max
	4	5	6
	7	8	9
	.	0	±
15_			sec
←			Curr. End

until mem. full	
NO2	0 ppm
CO	
CO2	
SO2	
NO	
NOx	
SOx	
Drgh	
Gas time	
Rinse time	
ESC OK	

Gas time			
+5	+10	+240	
Min	1	2	3 Max
	4	5	6
	7	8	9
	.	0	±
+10_			min
←			Curr. End

Rinse time			
+5	+5	+240	
Min	1	2	3 Max
	4	5	6
	7	8	9
	.	0	±
+5_			min
←			Curr. End

Info	01/02
Meas. program: not active	
Start:	Manual
End:	Memory full
M. rate:	15 sec
Gas time:	10 min
Rinse time:	5 min
Mean:	No
ESC OK	

2. Description of the applications

2.13 Long-term measurement of flue gas with the base system – Control Unit

Measuring program is configured

The symbol  in the status bar of the measuring menu indicates that a measuring program is configured. Beginning of the long-term measurement with **Start** (not **PStart**).

Measuring program configured

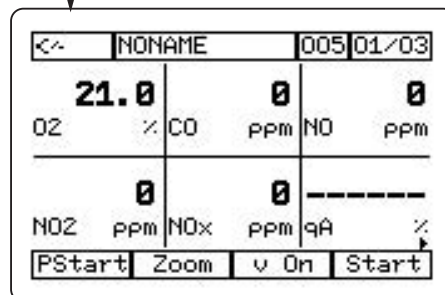

Starting a long-term measurement

The long-term measurement begins with the “Fresh air/Rinse” (see also configuration phase after switching on the instrument).

Measuring program running

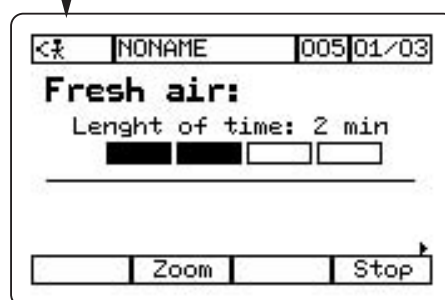

Fresh air time following start:

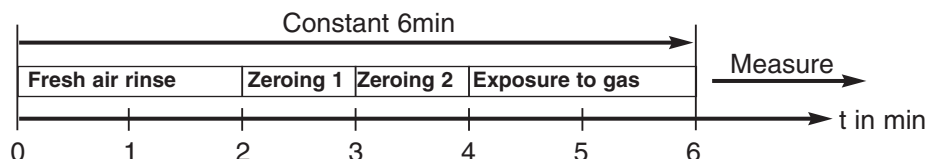

Fresh air time between measuring cycles:

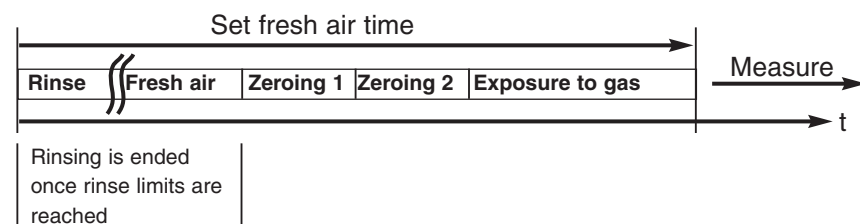

Note:

Minimum and maximum measuring and fresh air cycles

Measuring cycles: 2 min to 240 min (4 h)

Fresh air

cycles: 5 min to 1440 min (24 h)

Measuring program runs in accordance with programming, as shown by the symbol  in the bar..

Stop ends the programmed measurement ahead of time.

Note:

Generally, there is a rinsing phase of 2 minutes after the measuring program is finished (pump slows).

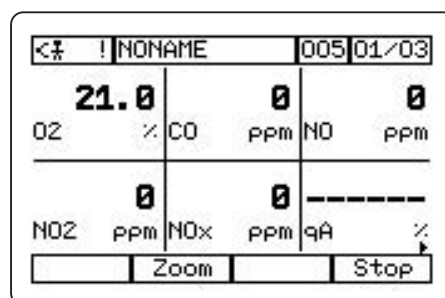

2. Description of the applications

2.13 Long-term measurement of flue gas with the base system – Control Unit

Restarting measuring program

The measuring program is restarted depending on the programmed end criteria.

If an analysis box is switched off and switched off again, the measuring program last set is called up again via the menu item Program → **Info** .
The menu item Program → **Delete** only inactivates a measuring program but does not delete it.

The measuring program is reactivated in accordance with the following table:

Starting criterion	Ending criterion					
	Date/Time	Manual	Trigger 1 → 0	Trigger 0 → 1	Memory full	No. of values
Date/Time	Inactive	Inactive	-	-	Inactive	Inactive
Manual	-	Active	-	-	Active*	Active
Trigger 1 → 0	-	Active	Active	Active	Active*	Active
Trigger 0 → 1	-	Active	Active	Active	Active*	Active

* The program is only active for as long as memory space is still available.

2.14 Long-term measurement of flue gas with the base system – BUS



2. Description of the applications

2.14 Long-term measurement of flue gas with the base system – bus

Measuring program

In the main menu, → →

4 Start criteria

Manual: On a keystroke in the measuring menu (function key)

Date/Time: Beginning of measurement at the selected date/selected time

Trigger: If the trigger input option is fitted (testo 350 XL only)

Trigger input: The following parameters can be adjusted for the trigger input:

- The measuring program is started when a rising flank is detected in the trigger signal. The program is also stopped by a rising flank.
- The measuring program is started when a falling flank is detected in the trigger signal. The program is also stopped by a falling flank.
- With level-dependent trigger signals, the data recording proceeds at the adjusted measuring rate as long as the trigger signal is active.

Mean

With Mean , only the mean values are stored.

Measuring rate

The storage cycle of the readings is adjusted under “Measuring rate”.

2. Description of the applications

2.14 Long-term measurement of flue gas with the base system – bus

Example with 10 flue gas analyser boxes

Connecting the system

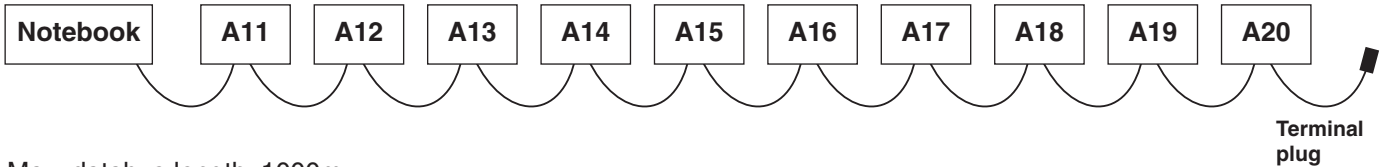

Max. databus length: 1000m

Only use original Testo bus cables.

Activating the system

1. Preliminary check:
 - Is the power supply connected correctly?
 - Do the LEDs show the correct function?
 - Are the bus connections attached correctly?
 - Is the terminal plug connected correctly?
2. Switch on notebook and start testo ComSoft software.
3. Activate bus connection: Click twice on “Bus connection” or via context menu (right mouse button: click on “bus connection”), “Open”.
4. Check if all connected flue gas analyser boxes are available.
5. Activate all flue gas analyser boxes: click twice on instrument name or “Open” via context menu (right mouse button: click on instrument name).
 - If connections are open, the symbol in front of the instrument name has a light green display, and a dark green display if connections are closed.

Setting up a new instrument group and displaying all NO_x values

1. Context menu (right mouse button: click on “bus connection”), “New instrument group”.
2. Select required readings of each flue gas analyser box (in this case: “NO_x”) and allocate name to instrument group.
3. Context menu (right mouse button: click on required instrument group), “ONLINE Configuration”.
4. Select measurement cycle and confirm with “OK”.
5. Context menu (right mouse button: click on instrument group, in this case: “NO_x”), “ONLINE”, “Start”.
 - The NO_x readings of all the flue gas analyser boxes belonging to the instrument group are shown.

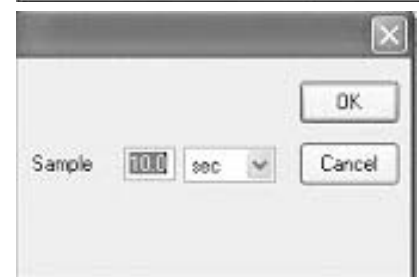
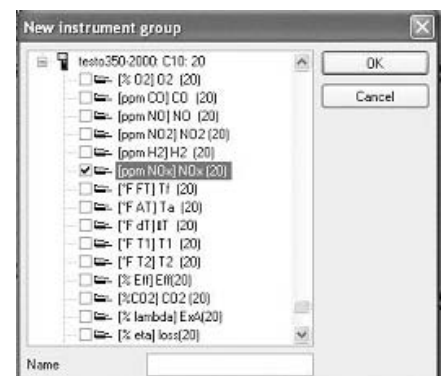

2. Description of the applications

2.14 Long-term measurement of flue gas with the base system – bus

Display all the readings of a specific flue gas analyser box

1. Context menu (right mouse button: click on instrument name of the required flue gas analyser box), “ONLINE”, “Start”.
- All the readings of the selected flue gas analyser box are shown.

Program long-term measurement

1. Context menu (right mouse button: click on the instrument name of the required flue gas analyser box), “Device control”.
2. Set up measurement program and confirm with “OK”.

Troubleshooting

Processing existing instrument group:

Existing instrument groups can only be processed if they are not activated. Close the instrument group prior to processing: Context menu (right mouse button: click on instrument group), “Close”.

Missing readings:

Check bus connections and power supply.

LEDs in flue gas analyser box do not light up:

Remove the mains cable and wait until the pump is no longer operating. Reconnect the instrument to the mains cable.

The software is no longer able to show the selected readings of an instrument group because the measurement cycle of a flue gas analyser box was changed: close the instrument group and reset the measurement cycle.

The time phases in which the new readings in the software are shown are far longer than specified in the measurement program: the connection to one or several flue gas analyser boxes is defective or non-existent. Check that the bus connections, terminal plug and power supply are connected properly.

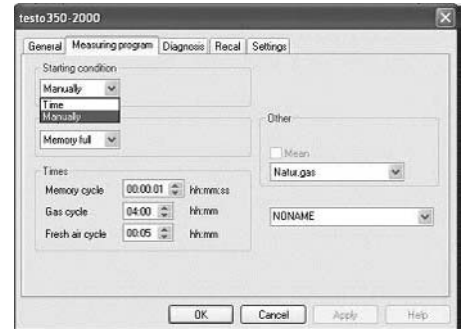

2.19 Online PC RS-232 – Control Unit



2. Description of the applications

2.19 Online PC RS-232 – Control Unit

Requirements

You have connected the Control Unit via RS-232 to the COM port of your PC. All probes are connected to the Control Unit. The Control Unit is switched on and the Comfort-Software has been started.

Operation

If the device has already been set up, the device icon is contained in the tree to the left with the name **testo350-454**. You can select the Control Unit after double clicking on this.

Confirm the selection and then click again with the right mouse button on the device icon. Open the device and the select "Device control".

This opens the main device window with general information on the Control Unit.

For example, the current date and time of the Control Unit, which you can synchronise with the PC here.

Observe:

Loggers and flue gas analyser boxes connected later to the Control Unit do not have their own clocks. These are controlled internally by the Control Unit.

You can assign a name to the Control Unit in the **Name** box. The device is then designated by this in the tree beside the device icon.

RS-232 selection

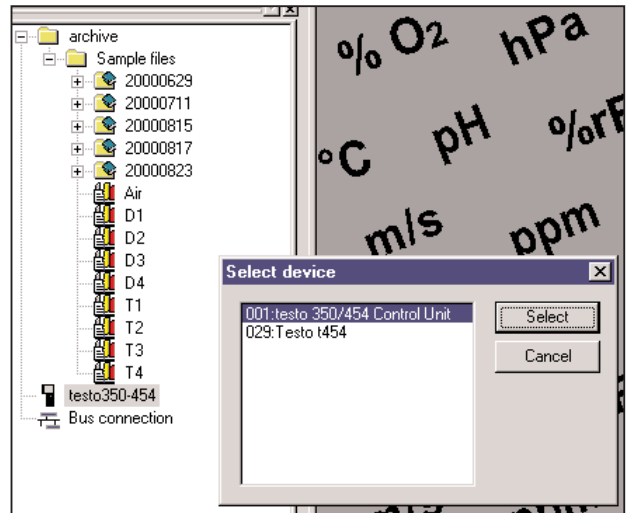

Device control

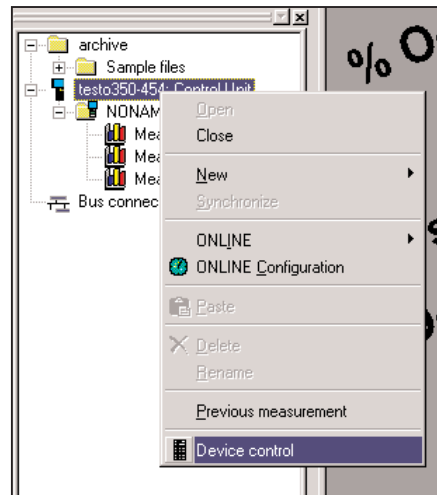

Device control

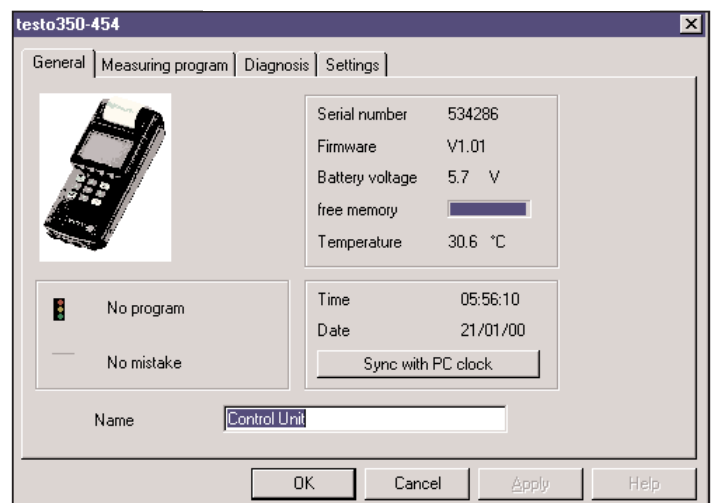

2. Description of the applications

2.19 Online PC RS-232 – Control Unit

“Measuring program” register:

You can program and execute an automatic storing program in the Control Unit here and program the automatic measurements with a start condition, a stop condition and a storing cycle. This describes the interval between two individually recorded readings of the connected probe.

After the start condition has been fulfilled, values are stored in the internal memory of the Control Unit at the rate of the adjusted cycle time. When the stop condition is reached, this contains a measurement protocol which can be found under the **Measuring program** entered and selected under **Location name**.

With **Apply** or **OK**, the measuring program is stored in the Control Unit. Terminate communications with the unit after closing the device control using the device icon with the **right mouse button** and **Close**. The Control Unit then processes the program independently of the connected PC.

When the program has been executed, i.e. when the stop criterion has been reached, you can reconnect the unit via the RS-232 connection to the PC. Open communications with the unit as described above. You will then receive the name of your Control Unit in the tree structure to the left of the device icon and the locations with the protocols stored under the locations beneath this.

In the menu, activate **Instrument**, **Read out data** to transfer the contents of the memory to the PC or drag individual protocols with the mouse cursor directly from the unit to the ComSoft 3 desktop on the right-hand side.

Read out data

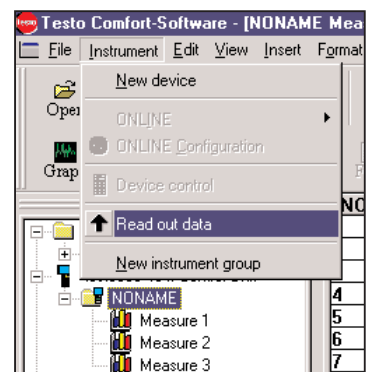

2. Description of the applications

2.19 Online PC RS-232 – Control Unit

“Diagnosis” register

If problems or functional faults occur, this contains a description of the fault and the possible remedial measures.

“Settings” register

You can configure all necessary parameters in the register **Settings**.

Pressure settings

The absolute pressure can be stored in the unit as a parameter for further calculations. This is required for density calculations in air velocity measurements with pitot tubes. The absolute pressure is also used to compensate the pressure in measurements with thermal velocity probes and CO₂ probes to convert the reading.

The absolute pressure is determined by the local altitude above sea level by the barometric altitude equation. The barometer value (current weather conditions during the measurement) and if necessary the pressure or underpressure in the channel in which the measurement is made in comparison with the ambient pressure must also be entered.

The result of this calculation is the determined absolute pressure, which can be stored in the unit with **Apply** oder **OK**.

Area

The Control Unit provides a means of opening a channel “Volume flow rate” in addition to air velocity measurements. The velocity values are converted according to the entered cross-section area of the channel and a volume flow rate is displayed in m³/h.

Select the channel shape and enter the associated dimensions.

The value **Factor** applies specifically to testo volume flow rate funnels for measurements at inlet openings. This factor is to be found in the operating instructions of the applied funnel.

Diagnosis

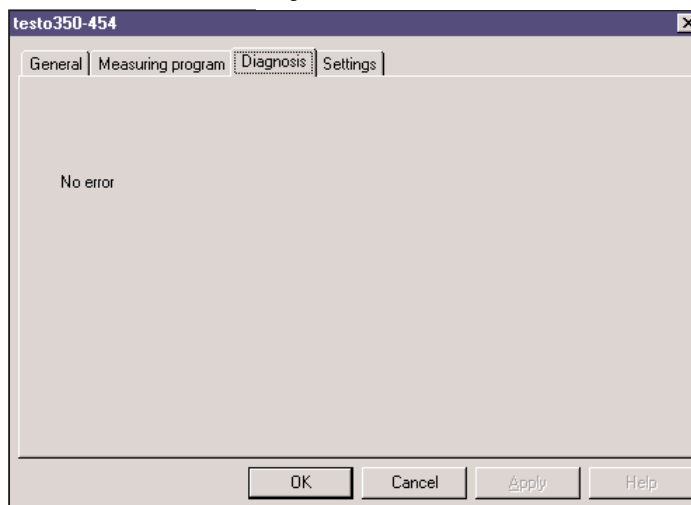

Pressure

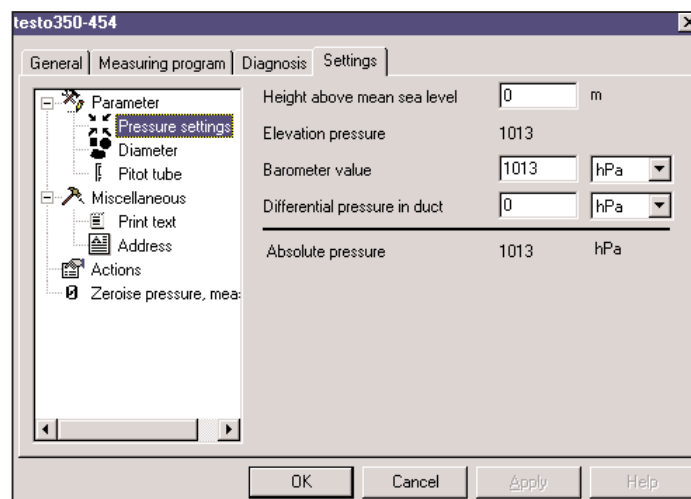

Area

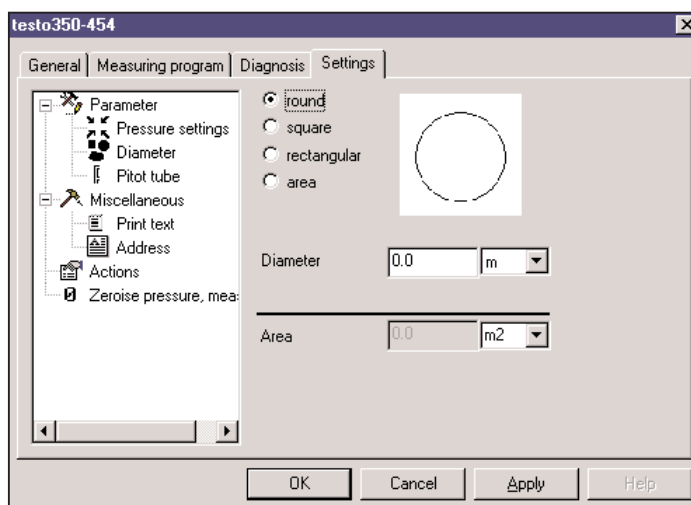

2. Description of the applications

2.19 Online PC RS-232 – Control Unit

Pitot tube

Factors can be entered under “Pitot tube” which have a direct effect on the m/s value. The pitot tube factor depends upon the type of the applied pitot tube. The standard testo pitot tubes have a factor of 1 or 0.67 for straight pitot tubes. The “Correction factor line” is a further factor, which should remain at 1 for standard applications.

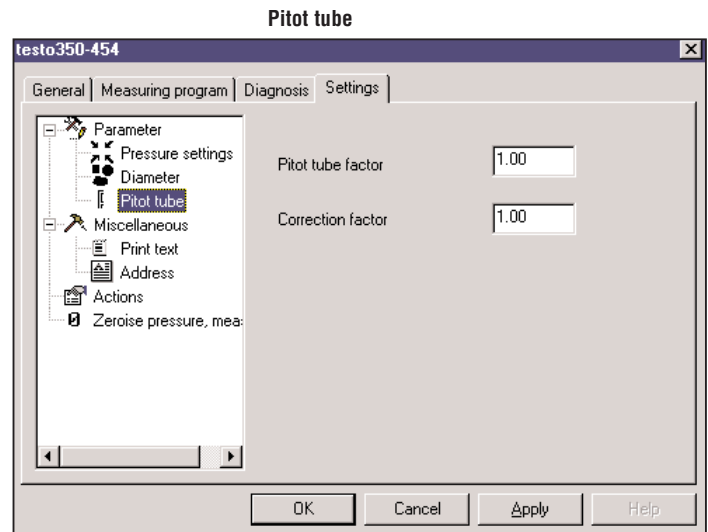

“Miscellaneous”, “Print text”

Four lines can be entered here which are printed by the printer integrated in the Control Unit. The first three lines appear at the beginning of the print-out and the footnote after the readings.

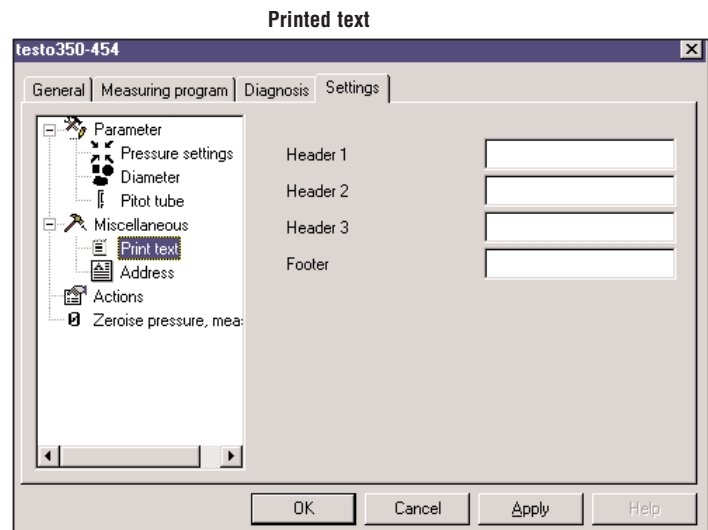

“Miscellaneous” “Address”

You can enter the entire address of your company or the user of the unit here. The address is stored in the unit and can be viewed in the main menu of the unit.

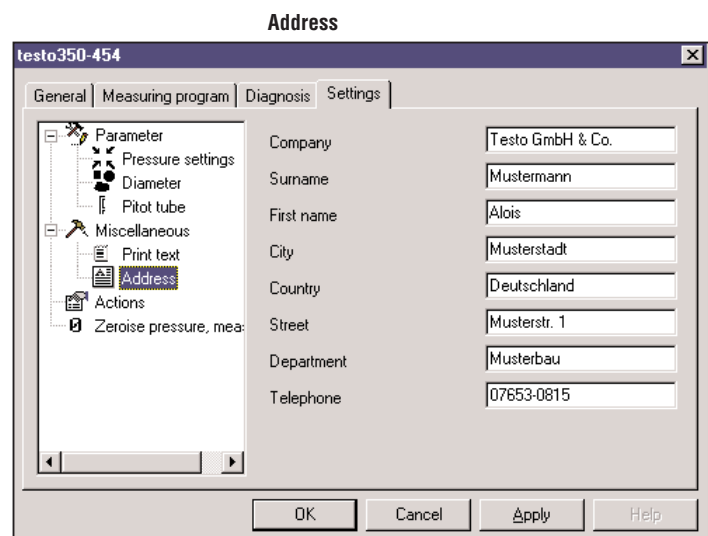

2.21 Online PC RS-232 with one or more loggers



2. Description of the applications

2.21 Online PC RS-232 with one or more loggers

Requirements

You have connected the Control Unit with one or more loggers via the RS-232 to the PC, the software has been started and all instruments are adequately supplied with power.

All probes to be used for the measurement are plugged into the appropriate sockets of the loggers.

Please observe that when several loggers are connected to the Control Unit, at least one powerbox or a bus mains adapter must be connected to the Testo databus.

If the Control Unit and the units are connected by a line at a longer distance, a bus terminator must be connected to the instrument most distant from the Control Unit. The status LEDs of all connected units must light steadily green or flashing green.

The RS-232 interface has been initialised by “Device”, “New device” and you see a device icon named testo 350-454 in the tree of the data section.

Operation

Activate the RS-232 by double clicking on the icon and you will receive a choice of the devices connected via RS-232 and the Control Unit to the PC.

Now select one of the loggers and click with the **right mouse button** on the opened device icon. In the next mask, select **Device control**. You will then enter the main mask to program the selected logger.

Specifically for online measurements, it is adequate to press **green start button** in the tool bar to start the online measurement. The selected logger begins directly at the cycle rate adjusted under **Device** → **Online configuration**.

All channels of the probes connected to the selected unit are displayed. It is also possible to switch between diagram, table or numeric matrix displays in the tool bar.

If you activate or have activated this in the menu bar with **View, Header**, you will also receive a text field which can be edited. This is printed together with the data.

You can stop the online measurement with the **red button** in the tool bar. The start button is then reactivated and you can resume the measurement or restart after closing the view window.

RS-232 initial screen

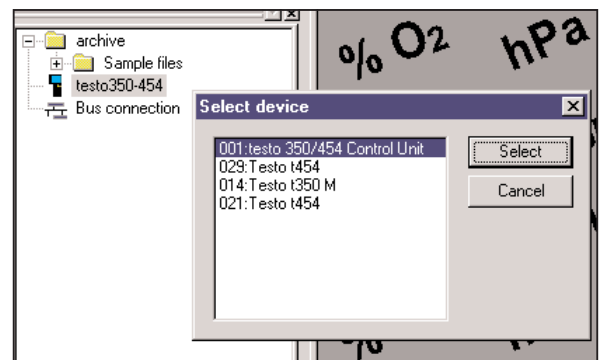

2.22 Online PC/RS-232 – base system, flue gas



2. Description of the applications

2.22 Online PC/RS-232 – base system, flue gas

Requirements

You have connected the analyser box via control unit and RS-232 to the PC, the software has been started and all instruments are adequately supplied with power.

The RS-232 interface has been initialised by “Device”, “New device” and you see a device icon named testo 350-454 in the tree of the data section.

Activate the RS-232 by double clicking on the icon, then you can choose between the control unit and the analyser box.

Operation (example)

Take the analyser unit for this example application and click with the right mouse key on the opened device icon. You will then enter the main mask to program the selected analyser box.

Select the **Settings** register:

Zero your analyser unit beforehand with **Actions**. You can zero the internal differential pressure sensors with **Zeroise, pressure, measurement**. Ensure that no differential pressure is applied to the sensors during calibration.

The following parameters should be checked and redefined if necessary for an online measurement:

Dilution

Activate the HC module (if installed).

Enter the factor for the CO measuring range extension.

If necessary, change the stored standard NO₂ increment of 5 %.

Fuel:

Enter the fuel for the

CO₂ calculation. If necessary, also the process values for O₂ reference and CO₂ max.

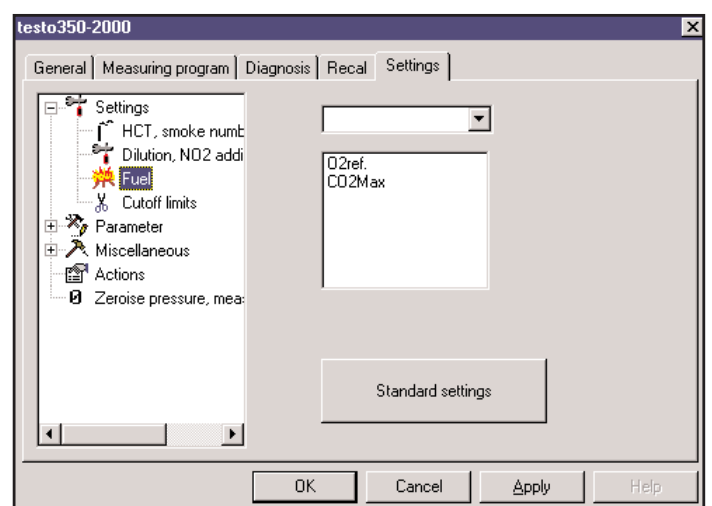
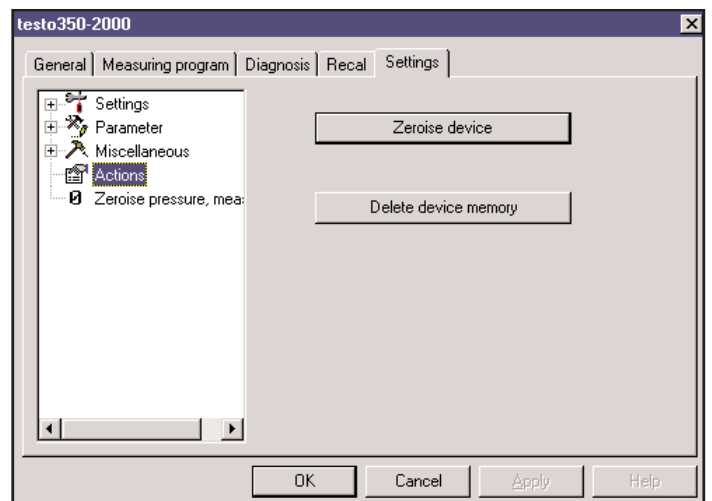
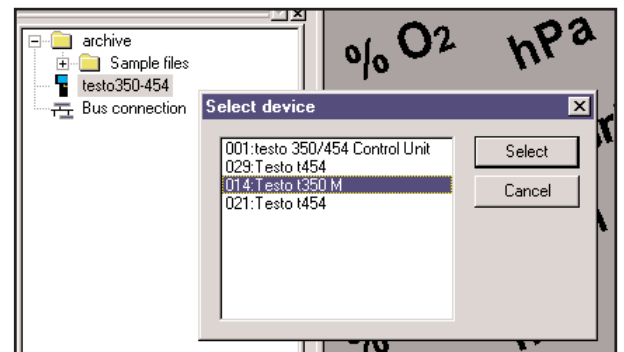

2. Description of the applications

2.22 Online PC / RS-232 – base system, flue gas

Switch-off thresholds:

Define the switch-off thresholds for the NO₂, SO₂ and HC cells.

If you are recording flow values or velocity values concurrently with the flue gas values, you must take account of and adjust the following parameters for the pitot tube measurement:

Pressure settings:

For the correct conversion of the differential pressure in the pitot tube into velocity according to the density, enter the values for the absolute pressure here. The altitude pressure is calculated from the local altitude by the barometric altitude equation.

Area:

A volume velocity is calculated from the geometries entered here and the measured velocity.

Pitot tube:

The pitot tube factor has an effect on the velocity calculation and depends on the type of pitot tube used.

The correction factor should be set to 1 for standard applications.

Dewpoint VL:

Apart from the absolute pressure, the humidity and temperature determine the conversion of the pitot tube pressure into air velocity. These values are specified here.

Specifically for online measurements, it is adequate to press the green start button in the tool bar to start the online measurement. The selected instrument begins directly with the cycle rate adjusted in "Device" -> "Online configuration".

All available channels of the selected unit are displayed.

It is also possible to switch between diagram, table or numeric matrix displays in the toolbar.

If you activate or have activated this in the menu bar with , you will also receive a text field which can be edited. This is printed together with the data.

You can stop the online measurement with the red button in the toolbar. The start button is then reactivated and you can resume the measurement or restart after closing the view window.

The analyser box in particular returns numerous channels. To attain a better overview, you can activate the channels which are of particular interest by clicking with the right mouse key on in the table field.

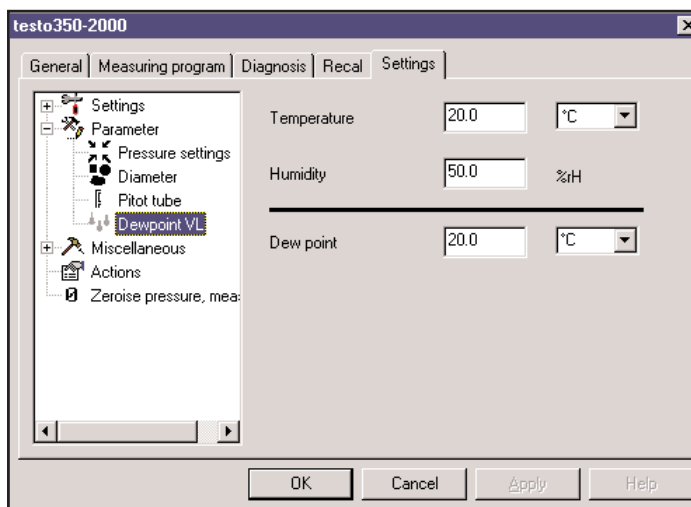

2.23 Online PC RS-232 – operation with one or more analyser boxes

2. Description of the applications

2.23 Online PC RS-232 – operation with one or more analyser boxes

The online measurement with one or more connected analyser boxes directly via the Control Unit is conducted in the same way as for the logger.

Select the appropriate components after double-clicking on **testo 350-454** and confirm with the **Select** button. The software then activates the green **Online Button** for this device in the toolbar.

The analyser box in particular returns numerous channels. To attain a better overview, you can activate the channels which are of particular interest by clicking on **Contents** **right mouse button** in the table field.

Note:

When you have connected several loggers or flue gas analysers together via the bus connection to the Control Unit, it is still only possible to activate one subscriber at any time via the RS-232 connection to the PC. This is conducted at the very beginning in the selection unit.

It is impossible to open several units concurrently to mix their channels. This is possible exclusively via the PCMCIA card, which makes a direct connection to the bus.

- 4. Service and maintenance, flue gas**
- 4.1 Maintenance and service, flue gas analyser

4.1 Maintenance and service, flue gas analyser

- 4.1.1 Recalibrating with test gas
- 4.1.2 Adjusting the CO₂ module / Saving calibration data
- 4.1.3 Table of recommended test gases by parameters
- 4.1.4 Measuring low concentrations
- 4.1.5 Table of cross sensitivities
- 4.1.6 Filter change/empty the condensate trap
- 4.1.7 Changing rechargeable batteries
- 4.1.8 Cleaning the pumps
- 4.1.9 Changing the condensate pump cassette
- 4.1.10 Changing cells
- 4.1.11 Extensions by the customer
- 4.1.12 Changing thermocouples in flue gas sampling probes
- 4.1.13 Information/Error messages
- 4.1.14 Guarantee periods of the instruments, the individual measuring modules and accessories

4. Service and maintenance, flue gas

4.1 Service and maintenance, flue gas analyser

4.1.1 Recalibrating with test gas

The gas sensors are factory calibrated so that they can be used in the entire measuring range.

Depending on the required accuracy, the sensors can be verified, recalibrated or calibrated to restricted measuring ranges with test gas (see next chapter for recommendations).

The calibration data is stored in the sensor's electronics, not in the instrument.

Verification and recalibration as necessary is recommended every six months to retain the specific accuracy of NO₂, H₂S, HC, CO_{low} and CO_{2i}.

Applying test gas:

Ideally, the test gas is applied directly to the tip of the probe to eliminate absorption in the gas path. The gas pressure must not exceed 30 hPa – ideally at zero pressure using a bypass.

Caution!

- **Observe safety regulations/accident prevention regulations when handling test gases.**
- **Use test gases in well ventilated rooms only!**

Note:

- Recalibration in the <500 ppm range (with CO₂-IR <25Vol.%) can lead to inaccuracies in the upper measuring range.
- If a HC sensor is fitted, switch this off before measuring test gases with an oxygen content of <2 %. If you forget to do this, the sensor will switch off automatically during the measurement, but is still strained unnecessarily.

Printing calibration data

Analyser box and control unit are connected, select analyser box

Via  → **Sensors** → **Print sensor data**

Prints data from last adjustment or last recalibration of every toxic measurement cell in the selected analyser box.

O₂ can only be checked and not recalibrated with the recalibration menu!

Note
If there is no calibration data in the sensor (e.g. sensors with a manufacturing date before January 2003) dashes are printed instead of the target and actual values. Only the serial number and date of adjustment are printed.

```
Analysis
Testo t350 XL

SN: 00509935 /D
John Q. Public
09.12.2002      15:35:25

Sensor data

O2 :
Ser.-No.      00401643
Target value  ----- %
Actual value  ----- %
Checked on:   -----

CO :
Ser. no.      00400649
Target value 1000 ppm
Actual value  0 ppm
Checked on:   07.2.2002

NO :
Ser.-no.      00407621
Target value  ----- ppm
Actual value  ----- ppm
Checked on:   -----

NO2:
Ser. no.      00236307
Target value  ----- ppm
Actual value  ----- ppm
Checked on:   -----
```

4. Service and maintenance, flue gas

4.1 Service and maintenance, flue gas analyser

4.1.1 Recalibrating with test gas

Apply test gas as described above to the unit when switched on.

Select **Sensors** -> **OK** -> **Recalibration** in the main menu.

Select **Gas sensor**

Enter the nominal value of the test gas -> **Start**: Recalibration begins.

Wait until the actual value is stable (at least 180 sec.).

The value is accepted and stored with **OK**.

Note:

- When dilution is switched on, recalibration can be conducted with the selected dilution level.
- Inaccuracy is higher when the measuring range extension is switched off.

Check analyser only (calibration)

Main menu -> **Sensors** -> **OK** -> **Recalibration** -> **OK** ->
CO, NO, NO₂, CxHy -> **OK** -> Enter target value -> **Start** -> **Save** ->
Target/Actual value and Date/Time of check are saved.

New adjustment of analyser (No check / calibration data saved)

Main menu -> **Sensors** -> **OK** -> **Recalibration** -> **OK** ->
CO, NO, NO₂, HC -> **OK** -> Enter target value -> **Start** -> **OK** ->
Recalibration is carried out -> **ESC**

Check analyser and adjust anew

Main menu -> **Sensors** -> **OK** -> **Recalibration** -> **OK** ->
CO, NO, NO₂, HC -> **OK** -> Enter target value -> **Start** -> **OK** ->
Recalibration is carried out -> **OK**

Select cal gas (possibly other concentration for checking purposes)

Enter target value -> **Start** -> **Save** ->

Target/actual value and date/time of check are saved.

4. Service and maintenance, flue gas

4.1 Service and maintenance, flue gas analyser 4.1.2 Adjusting the CO2 module / Saving calibration data

The analysis box should be operating for approx. 30 min prior to adjustment.

Zero point adjustment:

When zero point adjustment is carried out, the default gradient adjustment is extrapolated mathematically and reset.

A zero point adjustment renders the gradient adjustment carried out last invalid or a gradient adjustment must be carried out after the zero point adjustment.

- 1 Select **Main menu --> Sensors --> Recal. --> CO2i** ,
and confirm with **OK**.



When using the absorption filter (CO₂ filter), please observe the application information included with the CO₂ filter.

- 2 Attach the absorption filter or supply test gas with 0% CO₂ to the analyser via the gas inlet. Confirm with **OK**.
- 3 Following a rinse time of at least 1 min, start zero point adjustment by clicking on **Start**.
- 4 Wait for the reading to be taken.
- Analyser changes to the Gradient menu.
- 5 Click on **OK** to go to gradient adjustment or click on **ESC** to return to measurement view.

The image shows two screenshots from the analyser's menu system. The top screenshot is titled 'Recalibration' and shows a list of options: 'S O2', 'I CO', 'Dev NO', and 'Ser CO2i'. The 'Ser CO2i' option is highlighted. To the right, a value of '21.00' is displayed. Below the list, there are fields for 'CO2', 'NO', 'ppm NO2', and 'ppm'. The bottom screenshot is titled 'CO2 IR Zeropoint calibr.' and shows 'CO2i: Meas.val. admis'. Below this, it displays 'Req. val.: 0.00 %' and 'Act. val.: 0.08 %'. At the bottom of this screen is an 'ESC' button.

Gradient adjustment:

A gradient adjustment should be carried out if it was established during a reading check with test gas that the sensor is outside the given tolerance or if the module should have a higher accuracy level at this test gas concentration. A gradient adjustment in the range <25Vol.% can lead to accuracy deviations in the measurement range >25Vol.%.

Zero point adjustment was carried out

- 1 Enter gradient value and confirm with **Start**.
- 2 Start gradient adjustment with **Start** (existing calibration data will be deleted).
- 3 Wait for reading to be taken.
- The message "Test gas Check?" appears.
- 4 Click on **OK** to go to test gas check or click on **ESC** to return to measurement view.

The screenshot shows the 'Recalibration CO2i' screen. At the top, there are three columns with values '1.00', '20.00', and '50.00'. Below these are 'Min' and 'Max' labels. A 3x3 grid of numbers is displayed: 1, 2, 3 in the first row; 4, 5, 6 in the second row; 7, 8, 9 in the third row. The number '0' is entered in the bottom row, followed by a '+' sign. Below the grid is a text input field containing '40_'. At the bottom, there are three buttons: a left arrow, 'Curr.', and 'Start'.

The screenshot shows the 'test gas concentration' screen. It has the same layout as the previous screenshot, with columns '1.00', '1.00', and '50.00'. The 3x3 grid contains the numbers 1 through 9. The number '0' is entered in the bottom row, followed by a '+' sign. Below the grid is a text input field containing '40_'. At the bottom, there are three buttons: a left arrow, 'Curr.', and 'Start'.

Cal gas test:

- 1 Enter required concentration and confirm with **Start**
- 2 Click on **Save** to save date of test and calibration data in the sensor (Cancel via **ESC**).
- Instrument changes to measurement view.

4. Service and maintenance, flue gas

4.1 Service and maintenance, flue gas analyser

4.1.3 Table of recommended test gases by parameters

Testo factory calibration

Parameter	Test gas concentration
CO _{low}	300ppm CO, 1,4% O ₂ , Rem. N ₂
CO	1000ppm CO, 1,4% O ₂ , Rem. N ₂
CO + CO _{low}	400ppm CO, 300ppm H ₂ , 5% O ₂ , Rem. N ₂
NO _{low}	40ppm, Rem. N ₂ and 300ppm NO, Rem. N ₂
NO	80ppm NO, Rem. N ₂ and 800ppm NO, Rem. N ₂
NO ₂	100ppm NO ₂ , Rem. synthetic air (SA)
SO ₂	1000ppm SO ₂ , Rem. N ₂ or SA
H ₂ S	200ppm H ₂ S, Rem. N ₂ or SA
HC	5000ppm CH ₄ , Rem. SA
CO ₂ -IR	17% CO ₂ , Rem. N ₂ and 40% CO ₂ , Rem. N ₂

In the case of fluctuating or unknown flue gas concentrations:

Parameter	Test gas concentrations (from ... to)
CO _{low}	50...400ppm CO, Rem. N ₂ or SA
CO	150...5000ppm CO, Rem. N ₂ or SA
NO _{low}	40...300ppm NO, Rem. N ₂
NO	80...1000ppm NO, Rem. N ₂
NO ₂	40...200ppm NO ₂ , Rem. SA
SO ₂	100...1000ppm SO ₂ , Rem. N ₂ or SA
H ₂ S	40...200ppm H ₂ S, Rem. N ₂ or SA
HC	0,4...4% HC, Rem. SA
CO ₂ -IR	2...40% CO ₂ , Rem. N ₂

Recommended gas combination (in general):

Composition
CO + NO + N ₂
SO ₂ + O ₂ + N ₂
NO ₂ + SA
H ₂ S + SA / N ₂
CH ₄ , C ₃ H ₆ , ... depending on the application propane, butane or methane + SA

4. Service and maintenance, flue gas

4.1 Service and maintenance, flue gas analyser

4.1.4 Measurements of low concentrations

Observe the following recommendations in order to ensure accurate readings when measuring low gas concentrations.

1. Smallest possible adjustment value for measurements in the lower measurement range:

Gas	Lowest gas concentration	Testo adjustment
CO	150ppm	1000ppm
CO _{low}	50ppm	300ppm
NO	80ppm	80/800ppm
NO _{low}	40ppm	40/300ppm
H ₂ S	40ppm	200ppm
SO ₂	100ppm	1000ppm
NO ₂	40ppm	100ppm
HC	4000ppm	5000ppm

2. Lowest gas concentration for checking purposes:

Gas	Lowest gas concentration
CO	10ppm
CO _{low}	5ppm
NO	10ppm
NO _{low}	5ppm
H ₂ S	10ppm
SO ₂	10ppm
NO ₂	10ppm
HC	4000ppm

Other conditions:

- Use absorption-free hose material.
- Test gas should be applied to probe tip.
- Use separate gases, e.g. NO with nitrogen as a carrier gas.
- Use instrument only when "warm" (warm-up time min. 20 min).
- Zero with clean air after 20 min
- Max. positive pressure of test gas: 30hPa, better: pressure-free via bypass
- Pump flow in analyser ≥ 0.5 l/min.
- Test gas should be applied for at least. 5 min.

4. Service and maintenance, flue gas

4.1 Service and maintenance, flue gas analyser 4.1.5 Table of cross sensitivities

Applies to new, unused sensors only.

The value "0" means: <1% cross sensitivity.

Target gas	Crossing gas										
	CO	NO	SO ₂	NO ₂	H ₂ S	H ₂	Cl ₂	HCl	HCN	CO ₂	C ₃ H ₈
O ₂	0	0	0 ^{*1}	0	0	0	0	0 ^{*1}	0	0 ^{*2}	
CO(H ₂)	—	0	0	0	0	0	0	0	0	0	
NO	0	—	0	< 5 % ^{*3}	0	0	0	< 5 %	0	0	
SO ₂	< 3 % ^{*3}	0	—	-110 % ^{*3}	0	< 3 %	-80 %	0	30 %	0	
NO ₂	0	0	0	—	-20 % ^{*3}		0	100 %	0	0	
HC	25 % ^{*3}	0	0	0	0	120 % ^{*3}	k.A.	k.A.	k.A.	0,4 % ^{*4}	
NOlow	0	—	0	< 5 % ^{*3}	0	0	0	0	0	0	
CO(HV)											
low	—	0	0	0	0	0	0	0	0	0	
H ₂ S	< 2 % ^{*3}	< 5 %	< 20 % ^{*3}	-20 % ^{*3}	— 0	10 %	0	0	0		
CO ₂ -IR	0	0	0	0	0					-	0

*1 No effect up to several 1,000 ppm. For crossing gas conc. in % range: 0.3 %O₂ per 1 %SO₂/HCl.

*2 0.3 %O₂ per 1 %CO₂; compensated.

*3 Compensated if the crossing gas is also measured by the instrument (i.e. if an appropriate sensor is installed in the instrument).

*4 Compensated.

4. Service and maintenance, flue gas

4.1 Service and maintenance, flue gas analyser

4.1.6 Filter change/empty the condensat trap

Filter change

1. If the filters are visibly dirty, they need to be changed.
2. Replace the filter if the pump performance drops (audibly).

In most cases, it is sufficient to replace the flue gas filter.

- To replace a filter, remove the filter cover by twisting to the left.
- Take out the used filter and insert the new filter.
- Screw on the filter cover.
- The cross strut of the filter housing must be aligned with the markings on the housing of the measuring unit.

Spare filters are available under Part no. 0554.3381.

Caution!

If the gas preparation (option) is integrated, a filter with a water trap must be used as the flue gas filter. Spare filter Part. no. 0554.3380.

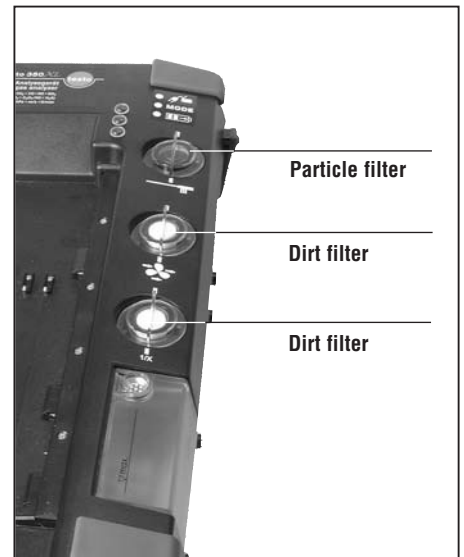

Filter housing Strut

Empty the condensate trap

Please note:

- Only empty the condensate trap when the pump is switched off.
- Do not damage the sealing rings when assembling the condensate trap.
- Pull out the condensate trap horizontally to empty the condensate.
- Open the drain plug.

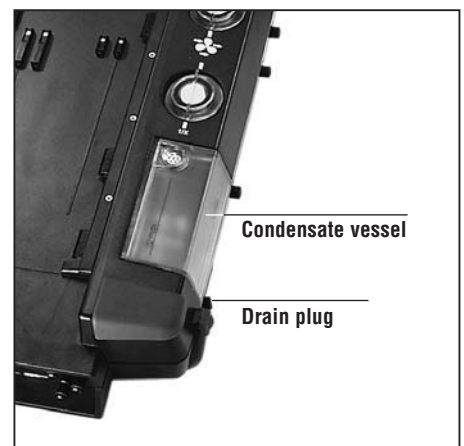

Condensate vessel

Drain plug

4. Service and maintenance, flue gas

4.1 Service and maintenance, flue gas analyser

4.1.7 Changing rechargeable batteries

Control unit

Rear

1. Disengage catch.
2. Remove battery pack and pull plug from socket.
3. Insert new rechargeable battery pack (observe marking on plug when plugging in). Make sure the battery label faces out.
4. Put on and close cover.

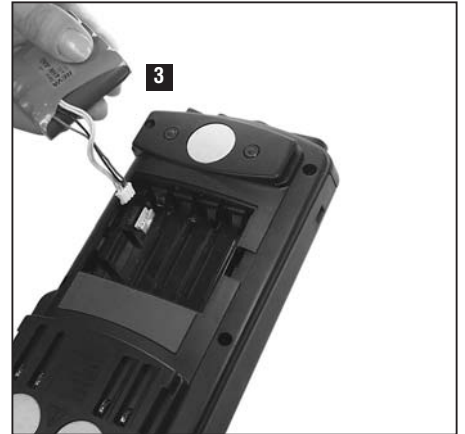

Analyser box

Rear

1. Disengage catch.
2. Remove battery pack and pull plug from socket after disengaging.
3. Insert new rechargeable battery pack (ensure that the plug engages).
4. Put on and close cover.



4. Service and maintenance, flue gas

4.1 Service and maintenance, flue gas analyser

4.1.8 Cleaning the pumps

Caution! Pull the mains plug before performing maintenance work.

1. Switch off the instrument and pull the mains plug.
2. Remove the condensate trap/condensate collecting vessel.
3. Disengage the three filter housings.
4. Unscrew the 8 Philips screws of the bottom of the housing.
5. Turn the instrument back over and remove the upper section of the housing.

Cleaning the main gas pump

1. Unscrew the Philips screw of the plastic pump holder.
2. Bend the plastic holder gently aside.
3. Pull the gas pump upwards from the gas measuring block.
4. Unscrew the 4 fastening screws of the pump head of the main gas pump.
5. Pull off the pump head.
6. Remove the two circlips from the depressions in the pump head (front and rear).
7. Remove and clean the pump diaphragm (e.g. spirit).
8. If necessary, blow through the inlet and outlet pipes with compressed air.
9. Reattach the pump diaphragms with the circlips.
10. Place the pump head on the main gas pump and fasten with the screws.
11. Place the pump back in the gas measuring block and fasten the pump to the plastic pump holder with the Philips screw.
12. Put on the upper section of the housing. Ensure that no wires are trapped.
13. Turn the instrument over and tighten the 8 Philips screws firmly.
14. Mount the filter housing on the condensate trap/condensate collecting vessel.

Housing screws

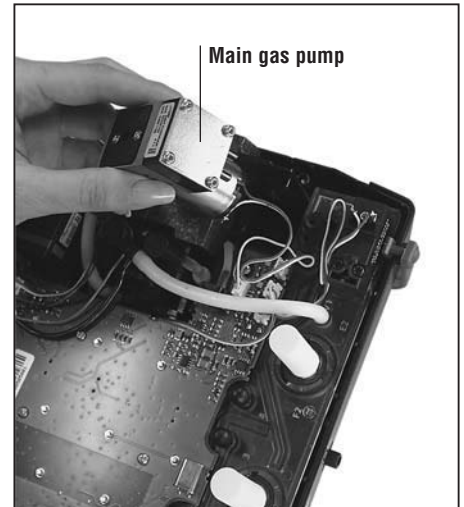
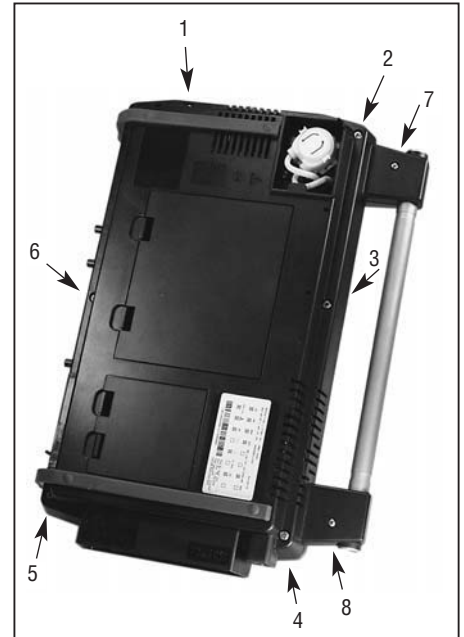

4. Service and maintenance, flue gas

4.1 Service and maintenance, flue gas analyser

4.1.8 Cleaning the pumps

Cleaning the rinsing pump/conveying pump for diluting gas

1. Unscrew the Philips screw of the plastic pump holder.
2. Bend the plastic holder gently aside.
3. Pull out the pump carefully.
4. Push the "Pump Tool" into the guides of the pump head.
5. Remove the "Pump Tool" from the pump head.
6. Remove the diaphragm holder from the pump head and remove the diaphragm.
7. Place the pump diaphragm in the diaphragm holder and insert in the pump head.
8. Place the pump head on the pump.
9. Remove "Pump Tool".
10. Insert pump in the installation block.
11. Place the pump back in the gas measuring block and fasten the pump to the plastic pump holder with the Philips screw.
12. Put on the upper section of the housing. Ensure that no wires are trapped.
13. Turn the instrument over and tighten the 8 Philips screws firmly.
14. Mount the filter housing on the condensate trap/condensate collecting vessel.

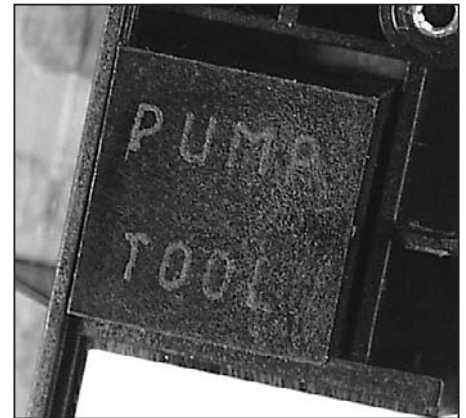
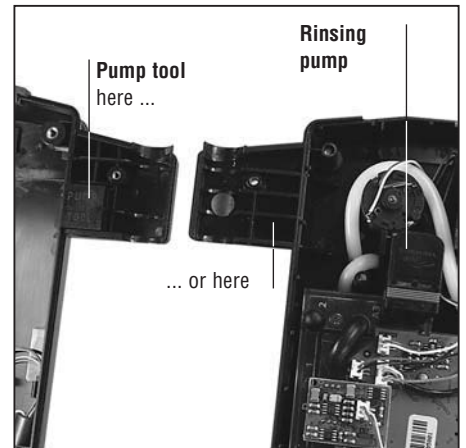

4. Service and maintenance, flue gas

4.1 Service and maintenance, flue gas analyser

4.1.9 Changing the pump cassette of the condensate conveying pump

1. Empty the condensate collecting vessel.
2. Remove the cover.



3. Disengage and pull off the pump cassette.
4. Remove the bend protection spring and push onto the hose at the suction side of the new pump cassette.
5. Push on the hose (see illustration).

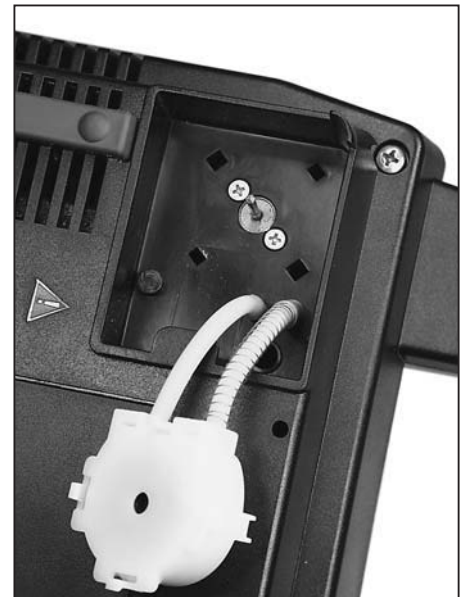

Caution!

Ensure that the hoses are not trapped or constrained.

Lay the hoses as illustrated.

6. Push the replacement cassette onto the motor shaft until it engages.
7. Attach cover.



4. Service and maintenance, flue gas

4.1 Service and maintenance, flue gas analyser

4.1.10 Changing cells

4.1.10.1 Changing measuring cells

- Switch off the unit and isolate from the mains.
- Open the large cover on the rear of the analyser box.
- Remove measuring cell heater.
- Pull the hose connections from the used cell.
- Remove the measuring cell from the unit.
- Insert and connect a new measuring cell.
- Push on the measuring cell heater.

Caution!

The O₂ measuring cell requires a compensation period of approx. 60 min. after replacement in the testo 350 M/XL. Only then can accurate measurements be made. The unit must not be switched on during this time.

The CO₂ IR measurement cell can only be changed at Testo service points.

If power supply to the NO measurement cell is interrupted, it takes 2 hours, once power has been reconnected, before the sensor is again ready to operate.

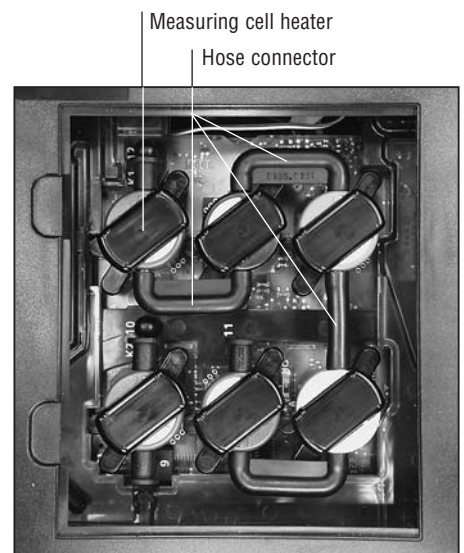
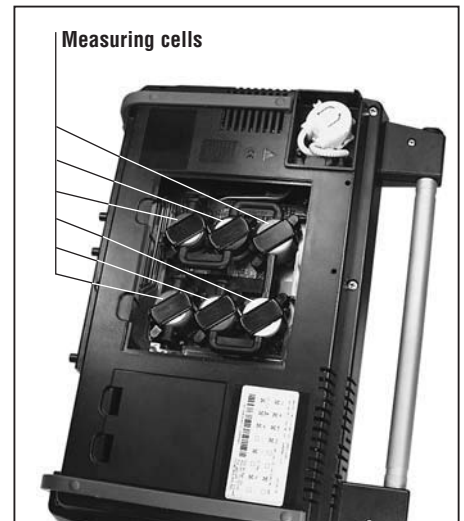

With unoccupied slot:
Plastic adapter in place of the measuring cell

4.1.10.2 Installing CO-/NO₂-/SO₂-/H₂S measuring cell

Caution!

Remove the short-circuit bridge when installing a new measuring cell.

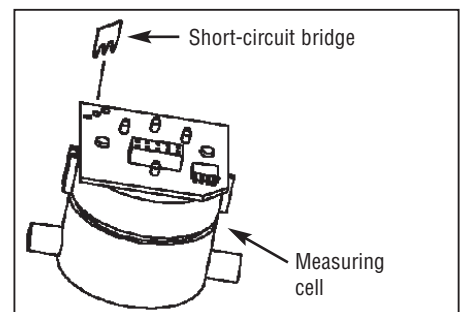

4.1.10.3 Installing NO measuring cell

Caution!

Remove the auxiliary circuit board before installing the NO cell.

Pull the additional circuit board from the NO cell (see drawing).

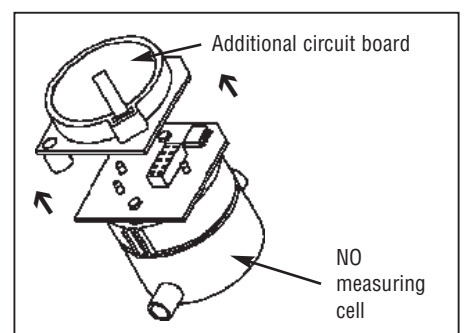

4. Service and maintenance, flue gas

4.1 Service and maintenance, flue gas analyser

4.1.11 Extensions by the customer

1. Switch the unit off.
2. Open the measuring cell cover.



Caution!

Extension modules are adapted at one of the empty slots. The measuring modules NO and HC must only be adapted at the slots marked "NO" and "Type A/HC" – observe switch settings. The measuring modules NO₂, SO₂, H₂S can be adapted at any desired slot marked "Type A" (see label on the measuring cell cover).

The CO₂ IR measuring cell can only be upgraded at Testo service points.

Measuring cell cover rear

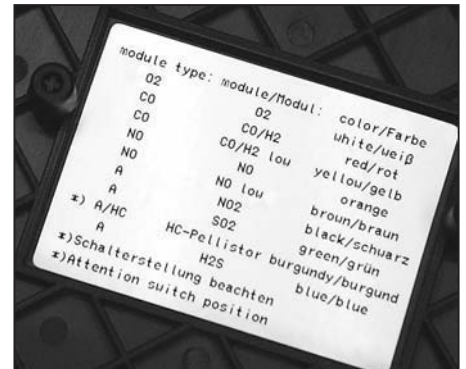

3. Remove the hose connector from the plastic adapter of an empty slot.
4. Remove the plastic adapter and replace this with the extension module.
Note
Remove the short circuit plug from the module board before installing the SO₂ module.
5. Adapt the hose connector to the gas hose nipple of the extension module.
6. Mount the cell heater on the extension module.
7. Close the measuring cell cover.
8. Switch on the unit with the adapted Control Unit or using the control software.
9. Insert the extended parameter in the display sequence (see menu "View").

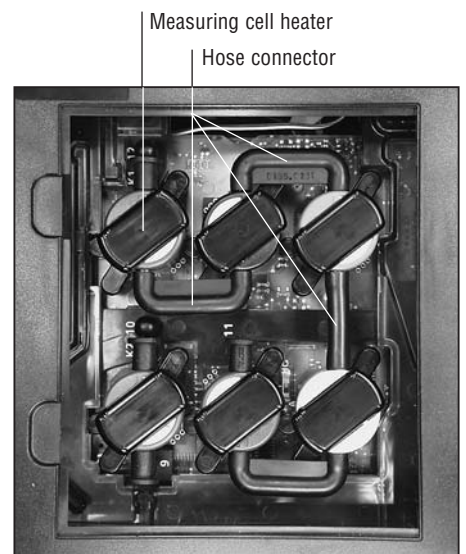

With unoccupied slot:
Plastic adapter in place of the measuring cell

4. Service and maintenance, flue gas

4.1 Service and maintenance, flue gas analyser

4.1.12 Changing thermocouples in flue gas sampling probes

Maintenance

Flue gas probe with coarse filter

After the measurement:

Cleaning condensate and deposits from the inner tube of the probe (remove outer shaft by opening the bayonet catch)

Cleaning the flue gas probe

If the flue gas is heavily laden with dust, it is possible that sections of the gas path preceding the hose filter will become contaminated or blocked.

Cleaning the flue gas probe with gas path closed

Pull off the probe shaft, place and move about in hot water. Then blow out with air or clean with a round brush (e.g. brass).

Coarse filter at the probe tip

The surface filter is easily cleaned. Minor dirt can be removed by blowing out with compressed air. For thorough cleaning, an ultrasonic bath or the use of a dental prosthesis cleaner is recommended. The filter must be replaced if encrusted or destroyed.

Filter change

1. Unscrew the filter cap with a 13 mm spanner.
2. Replace the filter insert with a new one.
3. Screw on the filter cap firmly with a 13 mm spanner.

Changing a defective thermocouple

Caution!

Remove the thermocouple only when defective. Pulling out the thermocouple by the connecting line can destroy it.

Remove the bend protection spring and pull the line out of the slotted hose.

Insert thermocouple until it slots into place. Position cable in the guides in the handle and push bending protection spring back in.

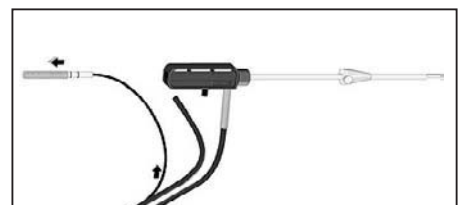
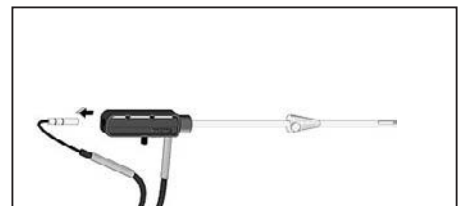
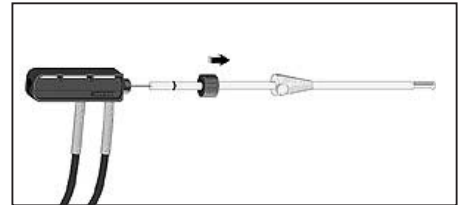
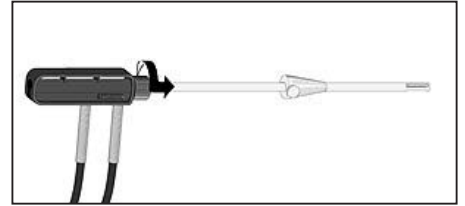

4. Service and maintenance, flue gas

4.1 Service and maintenance, flue gas analyser

4.1.13 Information/Error messages

Information/Error message	Cause	Remedy
NO value drifts	Loss of aux. voltage for NO	Measurement only after 2 h
Double module	Measuring module already installed	
Dilution	Gas flow rate in dilution path too high/too low	
O ₂ signal too high	O ₂ value above 20.9%	Switch unit off/on
O ₂ cell spent		Replace O ₂ cell
CO signal unstable	CO cell drifts excessively	Replace cell if necessary
CO signal too high	CO signal not at zero	Wait until regenerated
CO switch-off	CO value above selected shut-off threshold	
NO signal unstable	NO cell drifts excessively	Replace cell if necessary
NO signal too high	NO signal not at zero	Wait until regenerated
NO switch-off	NO value above selected shut-off threshold	
NO ₂ signal unstable	NO ₂ cell drifts excessively	Replace cell if necessary
NO ₂ signal too high	NO ₂ signal not at zero	Wait until regenerated
NO ₂ switch-off	NO ₂ value above selected shut-off threshold	
SO ₂ signal unstable	SO ₂ cell drifts excessively	Replace cell if necessary
SO ₂ signal too high	SO ₂ signal not at zero	Wait until regenerated
SO ₂ switch-off	SO ₂ value above selected shut-off threshold	
H ₂ signal unstable	H ₂ S cell drifts excessively	Replace cell if necessary
H ₂ S signal too high	H ₂ S signal not at zero	Wait until regenerated
H ₂ S shut-off	H ₂ S value above selected shut-off threshold	
Battery low	Connect instrument to the mains	
Unit temperature	Unit temperature is outside the operating temperature	
Pump flow rate	Too low/too high Gas flow rate	Check pump/gas path
Gas cooling system	Gas cooler not working	
Cell temperature too high	Cell temperature outside specifications	
Probe failure or probe not connected	Temperature probe not connected or thermocouple damaged	Connect temperature probe or exchange thermocouple
Ambient air temperature saved	No AT probe connected. The measured temperature of the flue gas probe is saved as an ambient air temperature	
Note: bus supply is switched off	The control can provide, for example, a testo 454 logger with power. If the internal voltage in the control unit is too low, the bus supply power is switched off (protection for internal battery/rech.battery)	Attach additional bus mains unit
Information that participant was cut off from BUS	Instrument was cut off from bus, e.g. by pulling out BUS plug or the power supply to the instrument is too low and for this reason the instrument switched itself off automatically	Check plug-in connection or recharge battery in unit concerned or attach mains unit
Input affects previously input values	Refers to programming of a save program. For example, end criteria is invalid because starting criteria was changed.	

4. Service and maintenance, flue gas

4.1 Service and maintenance, flue gas analyser

4.1.13 Information/Error messages

Information/Error message	Cause	Remedy
Cell no. x Sensor defective	The cell on the slot no. x is defective and must be renewed.	Please contact your local dealer or Testo Customer Service.
Check CO2 IR sensor	Various	Carry out zero point adjustment. If this is no longer possible: Please contact your dealer or the Testo Customer Service.

4. Service and maintenance, flue gas

4.1 Service and maintenance, flue gas analyser

4.1.14 Guarantee periods of the instruments, the individual measuring modules and accessories

Warranty

Units:	2 years (apart from wear parts and measuring cells)
CO/NO/NO ₂ /SO ₂ /H ₂ S/HC sensors, CO ₂ IR module:	1 year
O ₂ measuring cell:	1½ years
Probes:	1 year (apart from filter)
Rechargeable battery:	1 year
Accessories:	½ year
Printer:	1 year

5. Instrumentation notes, ventilation/air conditioning

- 5.1 Changing units
- 5.2 Entering parameters
- 5.3 Pitot tube factor
- 5.4 Adjusting the smoothing
- 5.5 Surface allowance

5.1 Changing units



5. Instrumentation notes, ventilation/air conditioning

5.1 Changing units

Each parameter can be assigned to a unit. Various systems of units are possible:

With , select -> **Device** -> **Units**.

Then select the desired parameter.

Table	
Parameter	units
Temperature	°C
	°F
Humidity	Off
	td°C
	g/m ³
	J/g
Velocity	m/s
	fpm
Flow rate	m ³ /h
	cfm
	m ³ /m
	m ³ /s
	l/s
	M ³ /h (standard volume flow)
Pressure	bar
	psi
	mmW
	Torr
	inHg
	kPa
Gas	ppm
	%

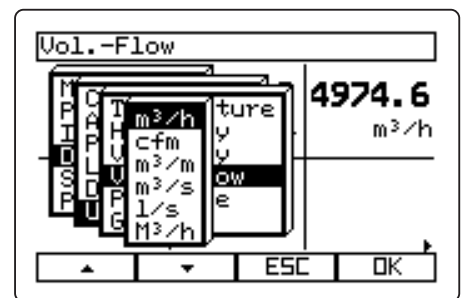
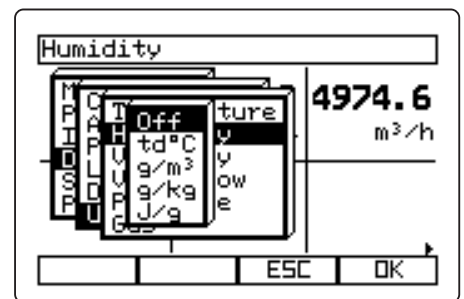
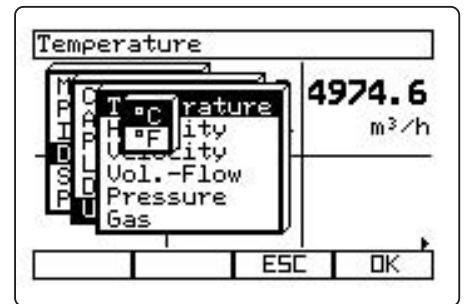
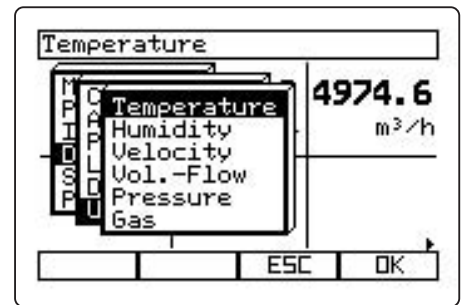
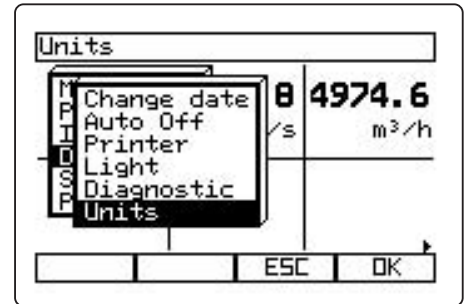
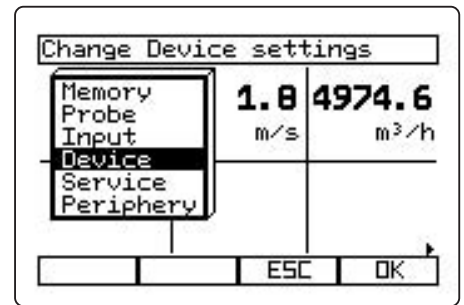

5.2 Entering parameters



5. Instrumentation notes, ventilation/air conditioning

5.2 Entering parameters

Manual adjustment of the parameters

The density can be entered under special parameters directly in g/m^3 (factory setting: $1,293 \text{ g/m}^3$).

When confirmed with **OK**, this value is used for the calculation. The individual values are not taken into account.

Alternatively, the values which influence the air density at the measurement point can be entered: temperature, relative humidity, absolute pressure.

When these values have been entered and confirmed with **OK**, the density is calculated automatically. The result is composed as follows:

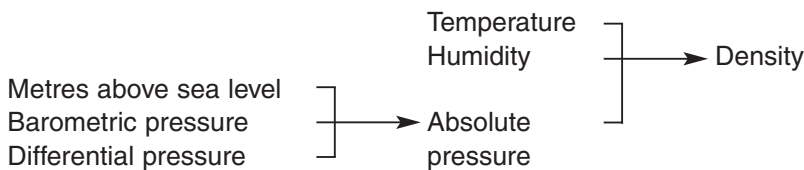

The absolute pressure can be entered as:

Altitude pressure (metres above sea level)

This is an annual average of 1,013 mbar at sea level. The higher the location above sea level, the lower the pressure.

Barometric pressure

This is an annual average of 1,013 mbar regardless of the altitude. Depending on the current weather, this pressure can fluctuate by ± 20 mbar from the annual average (see display of local barometer).

Differential pressure

This is the positive or negative pressure in the duct.

Note:

The entry of the absolute pressure (in hPa only; it is impossible to switch to other units) has an effect on the pressure-dependent measurement values. These are automatically compensated by the pressure. for humidity (g/kg, J/g), CO_2 and in all thermal probes.

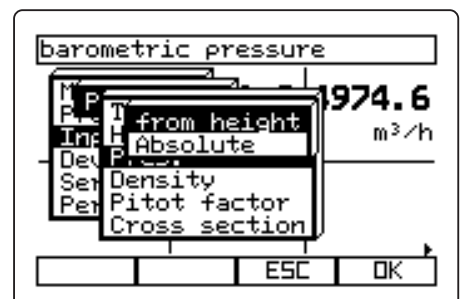
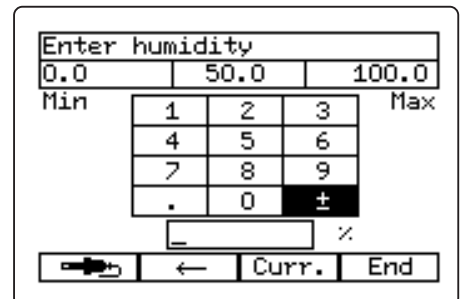
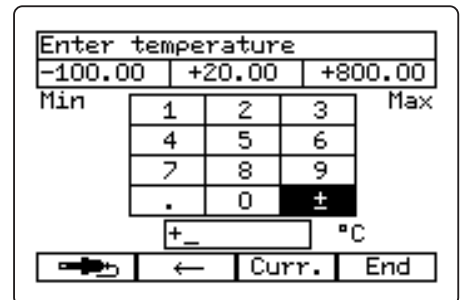
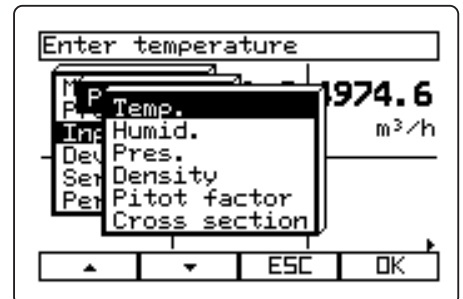
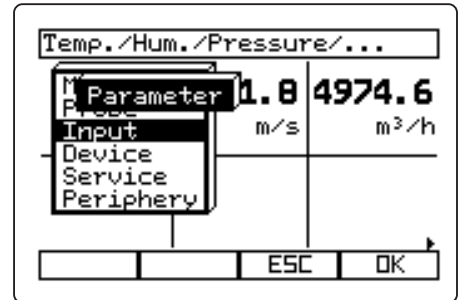
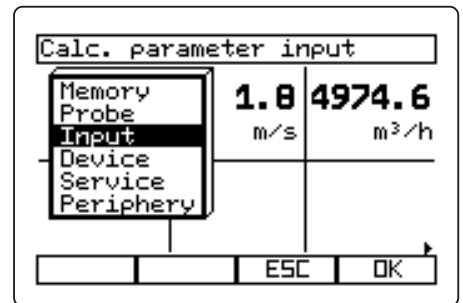

5. Instrumentation notes, ventilation/air conditioning

5.2 Entering parameters

barometric pressure	
1974.6	
Prop.	Pres.
Dev.	Metres above M.S.L.
Set	Diff. pressure
Per	Pitot factor
	Cross section
ESC OK	

barometric pressure		
400.0	1013.0	1400.0
Min		Max
1	2	3
4	5	6
7	8	9
.	0	±
_		hPa
→	←	Curr. End

Metres above M.S.L.		
0	0	9999
Min		Max
1	2	3
4	5	6
7	8	9
.	0	±
_		m
←		Curr. End

Diff. pressure		
-1000.0	+0.0	+1000.0
Min		Max
1	2	3
4	5	6
7	8	9
.	0	±
+_		hPa
←		Curr. End

Abs. pressure		
400.00	1013.00	4000.00
Min		Max
1	2	3
4	5	6
7	8	9
.	0	±
_		hPa
→	←	Curr. End

5.3 Pitot tube factor

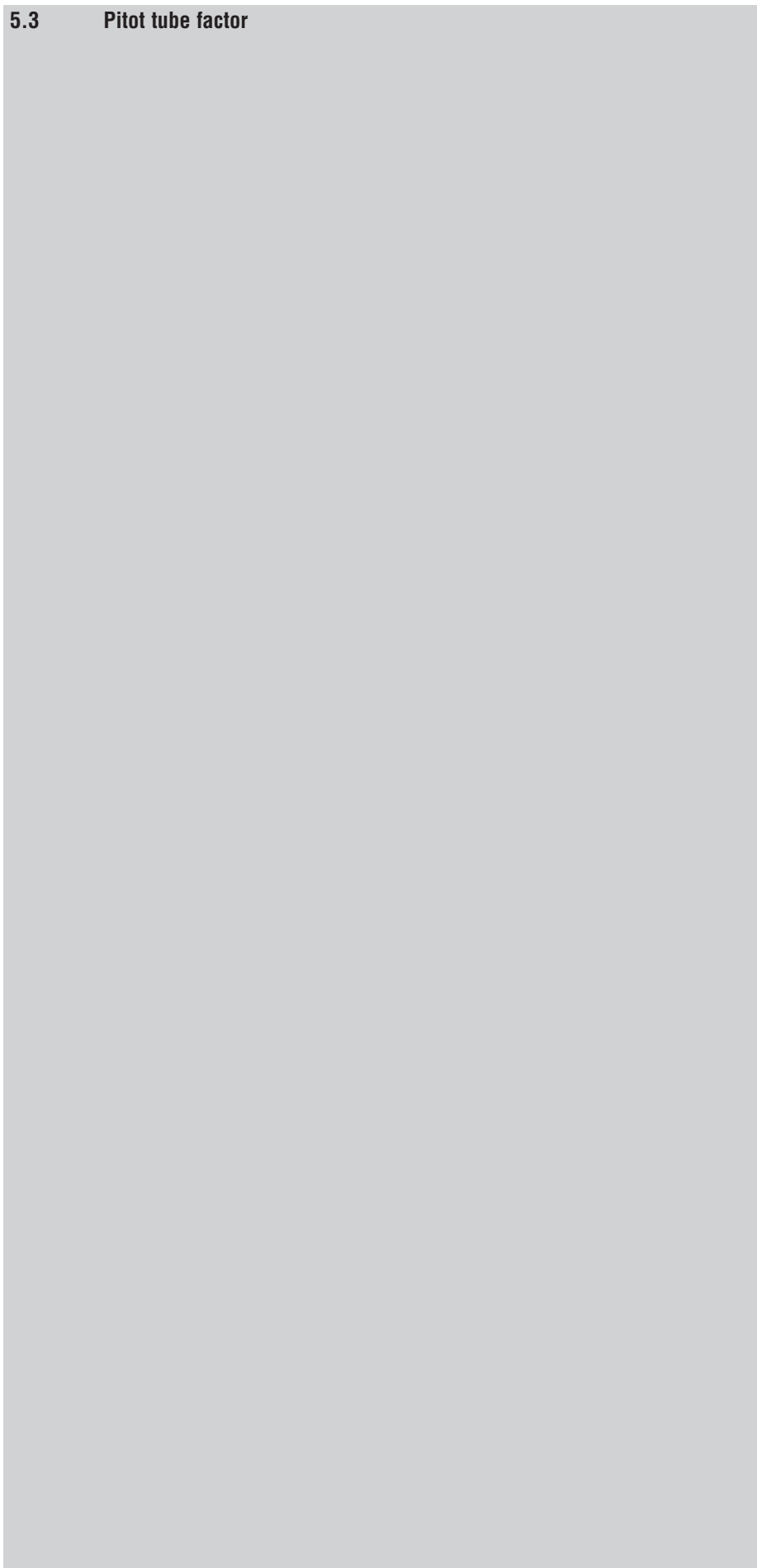

5. Instrumentation notes, ventilation/air conditioning

5.3 Pitot tube factor

Flow velocity and the pitot tube factor

In conjunction with a differential pressure probe, pitot tubes measure flow velocities.

The pressure probe produces the dynamic pressure from the difference of the total pressure and the static pressure.

The flow velocity is calculated as follows:

$$v = S \times \sqrt{\frac{2 \times P_{\text{dynamic}}}{\rho}}$$

S: Pitot tube factor

P_{dyn}: Dynamic pressure (Pa)

rho: density (kg/m³)

Set Pitot tube factor			
0.01	1.00	500.00	
Min	1	2	3
	4	5	6
	7	8	9
	.	0	±
[]			
	←	Curr.	End

barometric pressure			
400.0	1013.0	1400.0	
Min	1	2	3
	4	5	6
	7	8	9
	.	0	±
[] hPa			
→	←	Curr.	End

5.4 Adjusting the smoothing

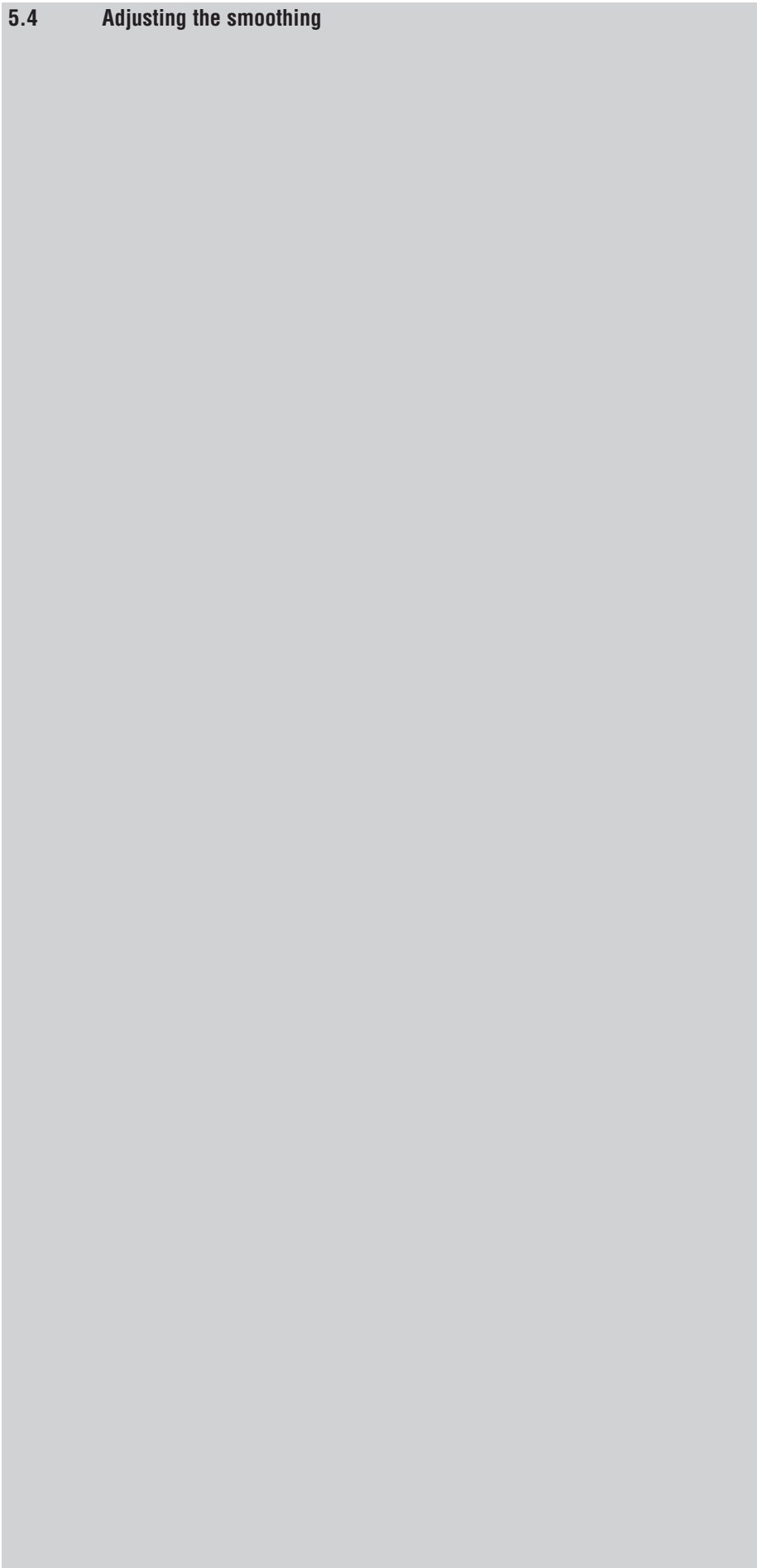

5. Instrumentation notes, ventilation/air conditioning

5.4 Adjusting the smoothing

If the readings fluctuate widely, it is advisable to smooth the readings. Smoothing is activated separately for each probe socket in the main menu under **Probe** → **Smooth**.

The number on the display stands for the degree of smoothing. The middle function key holds the associated unit (this can also be changed with the middle function key).

For example:

n = 2...10 means a running average up to 10 measurement cycles.

sec = 2...10 means a running average up to 10 sec.

off = 1 original values, smoothing deactivated.

Very heavily fluctuating readings can be smoothed by displaying the mean value of the last n values.

Smoothing can be adjusted by the number of values for each probe. The box from which the reading is received is insignificant.

The raw values are stored, i.e. the smoothed values pertain only to the view on the display.

The setting is always made for one probe, even if this supplies several parameters.

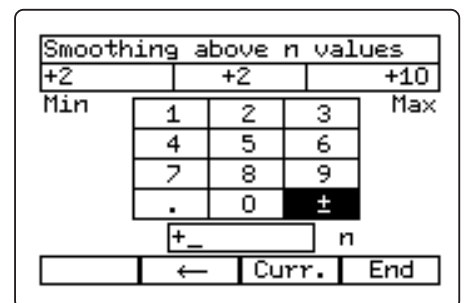
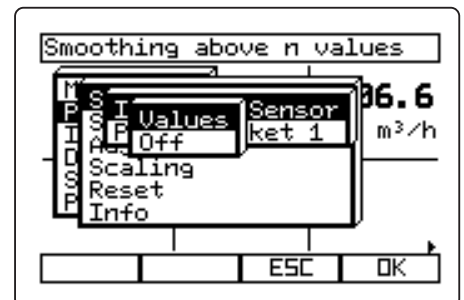
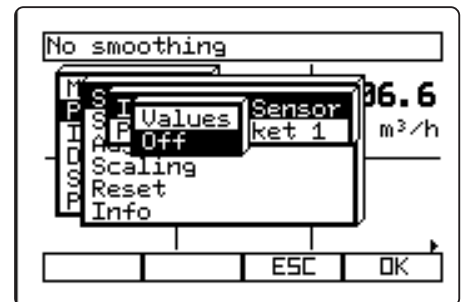
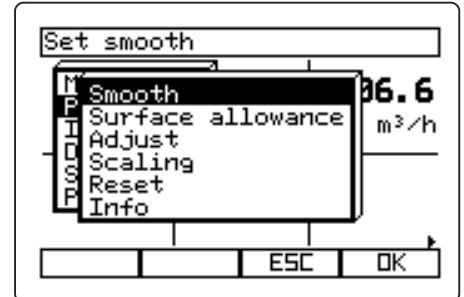
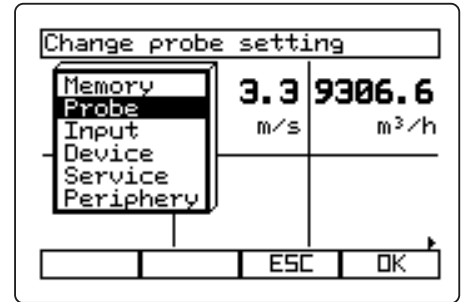

5.5 Surface allowance

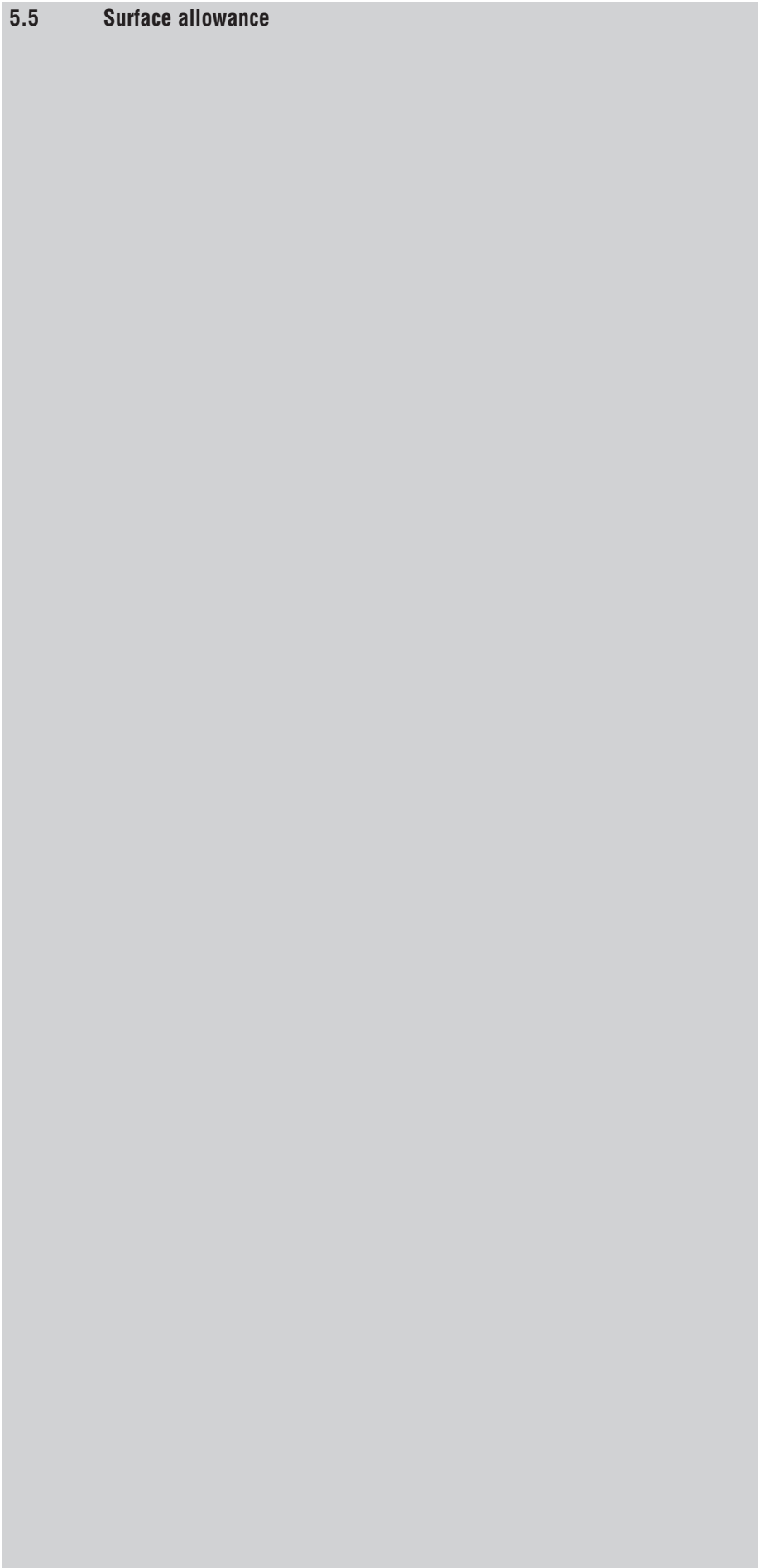

5. Instrumentation notes, ventilation/air conditioning

5.5 Surface allowance (SA)

Surface probes withdraw heat from the measured surface immediately after the initial contact. This makes the result of the measurement lower than the true surface temperature without the probe (or the reverse if the surface is colder than the environment). This effect can be corrected by an allowance in % of the reading.

The entry is made in the main menu under **Probe - SA** → **Surface allowance** and can be defined for probe sockets 1 or 2 separately (maximum 30 %).

All temperature probes are corrected by the entered value regardless of the selected location. The correction value is stored in the probes of EEPROM probes.

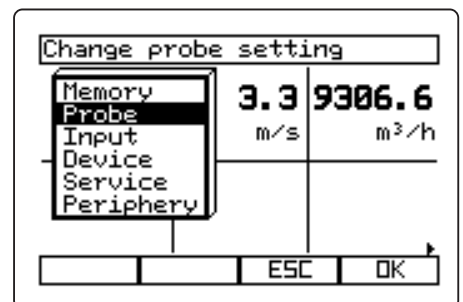
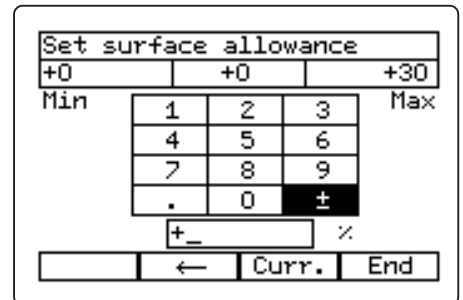
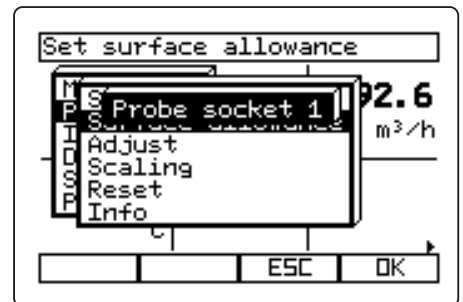
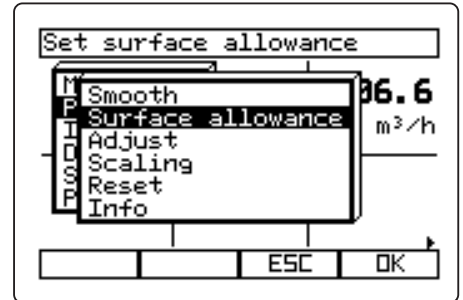
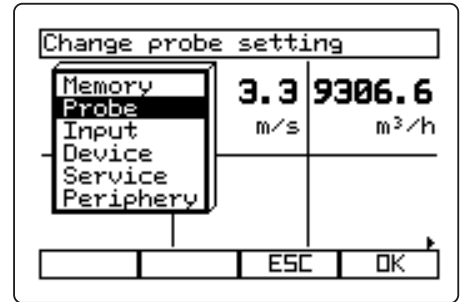

6. Instrumentation notes, flue gas

6.1 Principles of calculations

6.2 Suggestion for measuring and rinsing cycles of toxic sensors
(for long-term measurements)

6.1 Principles of calculations



6. Instrumentation notes, flue gas

6.1 Principles of calculations

The following equations were used to calculate the following values:

$$\text{CO}_2 \text{ value: } \text{CO}_2 = \frac{\text{CO}_{2\text{max}} \times (21 \% - \text{O}_2 \%)}{21 \%}$$

$\text{CO}_{2\text{max}}$: Fuel-specific maximum CO_2 value

21 % : Oxygen content of the air in %

O_2 % : Measured oxygen content in %

$$\text{Flue gas loss: } qA = \left[(\text{FT} - \text{AT}) \left[\frac{A2}{(21 - \text{O}_2)} + B \right] \right] - \text{KK}$$

FT : Flue gas temperature

AT : Ambient temperature

A2/B : Fuel-specific factors (see p. 2.4-10)

21 : Oxygen content of the air

O_2 : Measured oxygen content

KK : Is a factor which converts qA to a negative value at temperature shortfalls. Required for measurements in condensing furnaces.

If the fuel-specific factors A2 and B are equal to zero, the Siegert equation is used, applying the factor "f".

$$qA = f \times \frac{(\text{FT} - \text{AT})}{\text{CO}_2}$$

FT : Flue gas temperature

AT : Ambient temperature

CO_2 : Calculated CO_2 value

f : Fuel-specific factor

Combustion

$$\text{efficiency: } \eta = 100 - qA$$

If qA is negative, η becomes greater than 100 %.

$$\text{Air surplus index } \lambda : \lambda = \frac{\text{CO}_{2\text{max}}}{\text{CO}_2}$$

$\text{CO}_{2\text{max}}$: Fuel-specific maximum CO_2 value

CO_2 : Calculated CO_2 value

f : Fuel-specific factor

$$\text{NO}_x: \text{NO}_x = \text{NO} + [\text{NO}_{\text{surp}} \times \text{NO}]$$

NO_{surp} : NO_2 surplus factor

$$\text{CO}_{\text{undiluted}}: \text{CO}_{\text{undiluted}} = \text{CO} \times \lambda$$

CO : CO reading

λ : Air surplus index

6. Instrumentation notes, flue gas

6.1 Principles of calculations

$$\text{Flow velocity: } v \text{ (m/s)} = \sqrt{\frac{575 \times \Delta P \times (FT + 273.15)}{PAbs}} \times \alpha$$

- PAbs : Absolute pressure
 ΔP : Differential pressure in mbar
 FT : Flue gas temperature
 α : Pitot tube factor 0...1.50

$$\text{Volume flow: } V \text{ (m}^3\text{/s)} = v \times \frac{A1 \times A2}{10.000}$$

- v : m/s
 A1, A2 : cm

Calculation of the dew point temperature of the flue gas:

$$\text{Dew point temperature: } DpFG = - \frac{\ln \left[\frac{F_{H2O} \times PAbs}{610.78} \right] \times 234.175}{\ln \left[\frac{F_{H2O} \times PAbs}{610.78} \right] - 17.08085}$$

- TpAG : Dew point temperature of the flue gas
 F_{H2O} : Fuel-dependent steam factor (Vol.-%)
 PAbs : Absolute pressure in mbar

Calculation of mass flow CO, NO, SO₂, H₂S:

The emitted pollution can be calculated by the following equation:

$$\text{Mass flow CO: } CO = CO \left[\frac{\text{kg}}{\text{h}} \right] [\text{ppm}] \times F_{Gas} \times 1.25 \left[\frac{\text{kg}}{\text{m}^3} \right] \times \frac{273.15 \times P_{abs} \text{ [mbar]}}{273.15 + T[\text{°C}] \times 1013} \times V \left[\frac{\text{m}^3}{\text{s}} \right] \times 10^{-6} \left[\frac{\text{m}^3}{\text{ppm} \times \text{m}^3} \right] \times 3600$$

$$\text{Mass flow NO}_x: NO_x = NO_x \left[\frac{\text{kg}}{\text{h}} \right] [\text{ppm}] \times F_{Gas} \times 2.05 \left[\frac{\text{kg}}{\text{m}^3} \right] \times \frac{273.15 \times P_{abs} \text{ [mbar]}}{273.15 + T[\text{°C}] \times 1013} \times V \left[\frac{\text{m}^3}{\text{s}} \right] \times 10^{-6} \left[\frac{\text{m}^3}{\text{ppm} \times \text{m}^3} \right] \times 3600$$

$$\text{Mass flow SO}_2: SO_2 = SO_2 \left[\frac{\text{kg}}{\text{h}} \right] [\text{ppm}] \times F_{Gas} \times 2.86 \left[\frac{\text{kg}}{\text{m}^3} \right] \times \frac{273.15 \times P_{abs} \text{ [mbar]}}{273.15 + T[\text{°C}] \times 1013} \times V \left[\frac{\text{m}^3}{\text{s}} \right] \times 10^{-6} \left[\frac{\text{m}^3}{\text{ppm} \times \text{m}^3} \right] \times 3600$$

$$\text{Mass flow H}_2\text{S: } H_2S = H_2S \left[\frac{\text{kg}}{\text{h}} \right] [\text{ppm}] \times F_{Gas} \times 1.54 \left[\frac{\text{kg}}{\text{m}^3} \right] \times \frac{273.15 \times P_{abs} \text{ [mbar]}}{273.15 + T[\text{°C}] \times 1013} \times V \left[\frac{\text{m}^3}{\text{s}} \right] \times 10^{-6} \left[\frac{\text{m}^3}{\text{ppm} \times \text{m}^3} \right] \times 3600$$

- FGas : Fuel-dependent humidity factor
 T : Dew point

For conversion to other units, the corresponding conversion factors must be used.

Conversion of ppm to mg/m³ in relation to the O₂ reference index

$$\text{CO (mg/m}^3\text{)} \quad \text{CO} = \frac{21 - \text{O}_2 \text{ reference}}{(21 - \text{O}_2)} \times \text{CO (ppm)} \times 1.25$$

21 : Oxygen content of the air
 O₂ : Measured oxygen content

$$\text{NO}_x \text{ (mg/m}^3\text{)} \quad \text{NO}_x = \frac{21 - \text{O}_2 \text{ reference}}{(21 - \text{O}_2)} \times \text{NO}_x \text{ (ppm)} \times 2.05$$

21 : Oxygen content of the air
 O₂ : Measured oxygen content

$$\text{SO}_2 \text{ (mg/m}^3\text{)} \quad \text{SO}_2 = \frac{21 - \text{O}_2 \text{ reference}}{21 - \text{O}_2} \times \text{SO}_2 \times 2.86$$

$$\text{H}_2\text{S (mg/m}^3\text{)} \quad \text{H}_2\text{S} = \frac{21 - \text{O}_2 \text{ reference}}{21 - \text{O}_2} \times \text{H}_2\text{S} \times 1.54$$

Conversion of (ppm) to mg/kWh

$$\text{CO (mg/kWh)} \quad \text{CO} = \frac{21}{21 - \text{O}_{2 \text{ meas.}}} \times \text{CO (ppm)} \times \text{FBr} \times 3.6 \times 1.25$$

$$\text{NO}_x \text{ (mg/kWh)} \quad \text{NO}_x = \frac{21}{21 - \text{O}_{2 \text{ meas.}}} \times \text{NO}_x \text{ (ppm)} \times \text{FBr} \times 3.6 \times 2.05$$

$$\text{SO}_2 \text{ (mg/kWh)} \quad \text{SO}_2 = \frac{21}{21 - \text{O}_{2 \text{ meas.}}} \times \text{SO}_2 \text{ (ppm)} \times \text{FBr} \times 3.6 \times 2.86$$

$$\text{H}_2\text{S (mg/kWh)} \quad \text{H}_2\text{S} = \frac{21}{21 - \text{O}_{2 \text{ meas.}}} \times \text{H}_2\text{S (ppm)} \times \text{FBr} \times 3.6 \times 1.54$$

FBr = Conversion factor mg/mg³ in g/GJ

Conversion of ppm to g/GJ

$$\text{CO (g/GJ)} \quad \text{CO} = \frac{21}{21 - \text{O}_2 \text{ meas.}} \times \text{CO (ppm)} \times \text{FBr} \times 3.6 \times 1.25$$

$$\text{NO}_x \text{ (g/GJ)} \quad \text{NO}_x = \frac{21}{21 - \text{O}_2 \text{ meas.}} \times \text{NO}_x \text{ (ppm)} \times \text{FBr} \times 3.6 \times 2.05$$

$$\text{SO}_2 \text{ (g/GJ)} \quad \text{SO}_2 = \frac{21}{21 - \text{O}_2 \text{ meas.}} \times \text{SO}_2 \text{ (ppm)} \times \text{FBr} \times 3.6 \times 2.86$$

$$\text{H}_2\text{S (g/GJ)} \quad \text{H}_2\text{S} = \frac{21}{21 - \text{O}_2 \text{ meas.}} \times \text{H}_2\text{S (ppm)} \times \text{FBr} \times 3.6 \times 1.54$$

Efficiencies

$$\text{Eff. gros.} \quad \text{Effg} = 100 - \left[\left[\frac{K_{\text{gr}} \times (\text{FT} - \text{AT})}{\text{CO}_2} \right] + \left[\frac{X \times (2488 + 2.1 \times \text{FT} - 4.2 \times \text{AT})}{Q_{\text{gr}} \times 1000} \right] + \left[\frac{K_1 \times \text{CO}}{\text{CO}_2 + \text{CO}} \right] \right]$$

$$\text{Eff. net.} \quad \text{Effn} = 100 - \left[\left[\frac{K_{\text{net}} \times (\text{FT} - \text{AT})}{\text{CO}_2} \right] + \left[\frac{X \times (210 + 2.1 \times \text{FT} - 4.2 \times \text{AT})}{Q_{\text{gr}} \times 1000} \right] + \left[\frac{K_1 \times Q_{\text{gr}} \times \text{CO}}{Q_{\text{net}} \times \text{CO}_2 + \text{CO}} \right] \right]$$

$$X = \text{MH}_2\text{O} + 9 \times \text{H}$$

FT: Flue gas temperature

AT: Ambient temperature

K_{gr} , K_{net} , K_1 , Hydrogen content of fuel H, Moisture content of fuel MH_2O , Q_{gr} , Q_{net} , ref are all fuel-specific factors.

$$\text{Ratio} \quad \text{rat.} = \frac{\text{CO (ppm)}}{\text{CO}_2 \text{ (\%)} \times 100}$$

Density value for velocity measurement

$$\rho \text{ (kg/m}^3\text{)} = \text{O}_2 \times 0.0143 + \text{CO}_2 \times 0.0197 + (100 - \text{O}_2 - \text{CO}_2 \times 0.0125) \times (100 - \text{H}_2\text{O}_{\text{AG}}) / 100 + \text{H}_2\text{O}_{\text{AG}} \times 0,00833$$

If a CO₂ IR module (optional) is available, the measured value is used. Otherwise, the calculated value is used.

O₂ cross-sensitivity / compensation

$$\text{O}_2 = \text{O}_{2\text{unc}} \times \left[1 + \frac{\text{CO}_2 \times \text{CO}_{2\text{corr}}}{100} \right]$$

$\text{O}_{2\text{unc}}$ = Uncompensated O₂ value

$\text{CO}_{2\text{corr}}$ = Cross-sensitivity from sensor EEPROM (-0.4327)

for CO₂ is used:

$\text{CO}_{2\text{measured}} \leq \text{CO}_{2\text{max}} / \text{CO}_{2\text{calculated}}$

$\text{CO}_{2\text{measured}} > \text{CO}_{2\text{max}} / \text{CO}_{2\text{measured}}$

6.2 Suggestion for measuring and rinsing cycles in toxic sensors

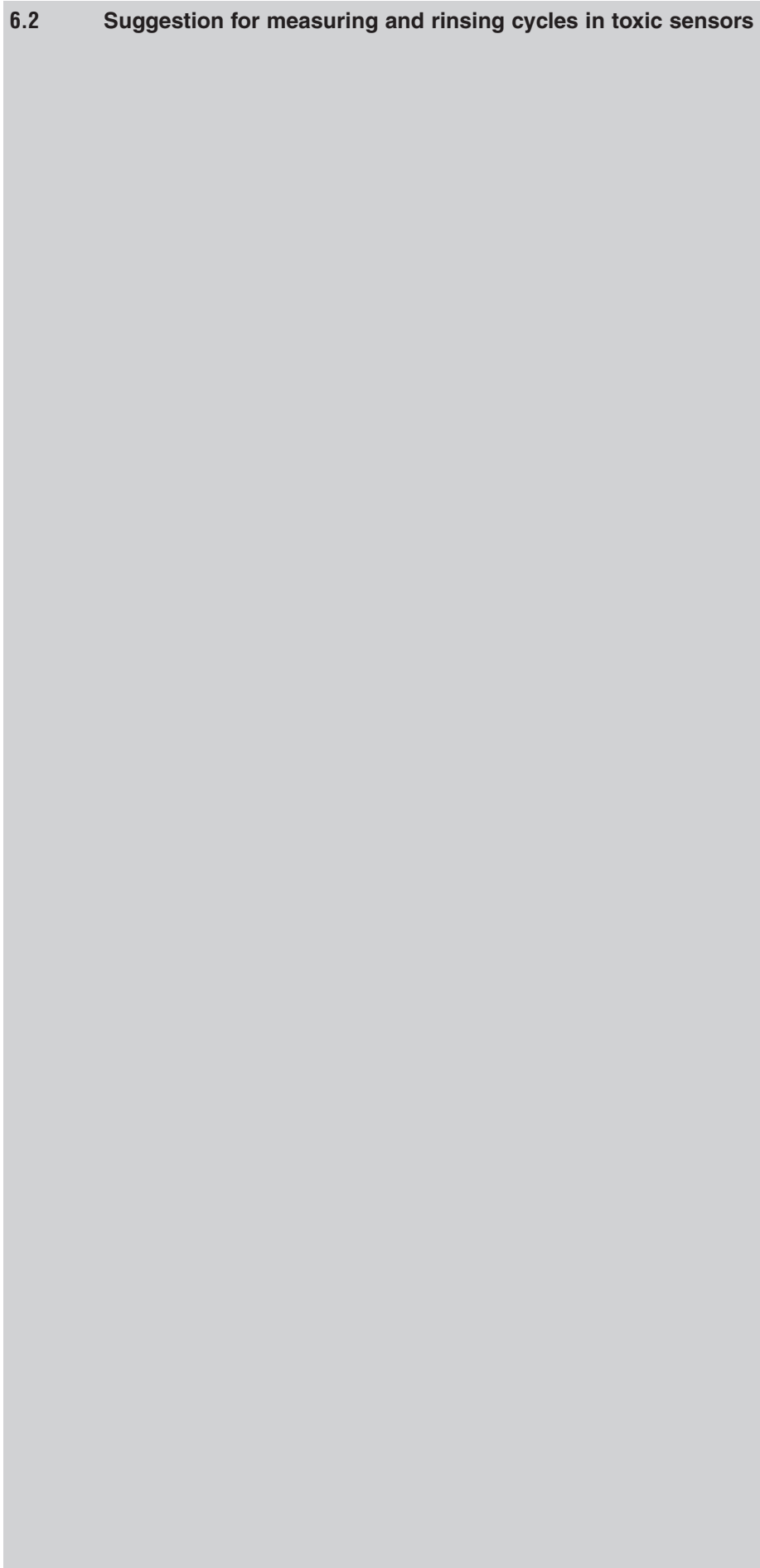

6. Instrumentation notes, flue gas

6.2 Suggestion for measuring and rinsing cycles in toxic sensors (for long-term measurements)

	Conc./ppm	Measurement/min	Rinses/min
1. COH ₂	50	60	5
	100	30	5
	200	20	10
	500	10	10
	1,000	10	15
	2,000	10	20
	4,000	5	30
	8,000	5	45
	10,000	5	60
2. COH _{2low}	10	60	5
	20	30	5
	50	20	10
	100	10	10
	200	10	15
	500	10	20
3. NO	50	60	5
	100	45	5
	200	30	5
	500	20	10
	1,000	10	10
	2,000	10	20
	3,000	5	30
4. NO _{low}	10	60	5
	20	45	5
	50	30	5
	100	20	10
	200	10	10
	300	10	20
5. NO ₂	10	60	5
	20	45	5
	50	30	5
	100	20	10
	200	10	10
	500	10	20
6. SO ₂	50	60	5
	100	30	5
	200	20	10
	500	15	10
	1,000	10	10
	2,000	10	20
	5,000	5	40
7. H ₂ S	10	40	5
	20	30	5
	50	20	10
	100	10	10
	200	5	10
	300	5	20
8. HC	rinsing cycles unnecessary if sufficient O ₂ in the flue gas (O ₂ shut-off...)		

7. Ordering data

7.1 testo 350 M/XL

7.2 testo 454

7.1 **testo 350 M/XL**

7.1.1 For existing measuring system

7.1.2 For additionally required measuring systems

7.1.3 Suitable probes

7. Ordering data

7.1 testo 350 M/XL

7.1.1 For existing measuring system

Ordering data for measuring instr. and accessories	Order no.	Ordering data for measuring instr. and accessories	Order no.
Spare thermal paper for printer (6 rolls)	0554.0569	O ₂ replacement measuring cell	0390.0070
Adhesive pockets (50 pieces) for printout	0554.0116	CO replacement measuring cell	0390.0088
Testo rechargeable battery pack	0515.0097	COlow replacement measuring cell	0390.0078
Mains unit for Control Unit	0554.1084	NO replacement measuring cell	0390.0074
Barcode pen	0554.0460	NOlow replacement measuring cell	0390.0077
Barcode labels (1,200 pieces)	0554.0411	NO ₂ replacement measuring cell	0390.0075
		SO ₂ replacement measuring cell	0390.0081
COlow measurement module	0554.3925	H ₂ S replacement measuring cell	0390.0079
NOlow measurement module	0554.3935	HC replacement module	0390.0076
NOlow measurement module	0554.3928	CO ₂ spare module	From factory only
NO ₂ measurement module	0554.3926	Refill pack of granulate material for CO ₂ filter	0554.0369
SO ₂ measurement module	0554.3927		
HC measurement module (only XL)	0554.3929	Rechargeable battery pack for analyser box	0554.1098
H ₂ S measurement module (only XL)	0554.3930		
CO ₂ IR upgrade	On request	Analyser gas pump	0239.0009
		Pump diaphragm for analyser gas pump	0193.0049
Comsoft 3 (PC software) for measurement data mgmnt. incl. connection cable	0554.0841	Rinsing and dilution pump	0239.0014
Testo PCMCIA plug-in card incl.		Pump diaphragm for rinsing and dilution pump	0193.0072
Comsoft 3 software, cable and adapter	0554.0590	Pump cassette for hose pump	0440.0013
Galvanic isolation for RS-232	0554.0006		
Connection cable for Control Unit/PC	0409.0178	Flue gas probe extensions:	
		Outer pipe with filter, length 335 mm	0554.3373
Wall bracket for analyser box with heat guard	0554.0203	Outer pipe with filter, length 700 mm	0554.3374
Carrying belt set for analyser box and Control Unit	0554.0434	Heat-proof probe pipe, Tmax. +1,000 °C, Length 335 mm	0554.7437
Transport case	0516.0351	Heat-proof probe pipe, Tmax. 1,000 °C, Length 700 mm	0554.7438
Service case with drawer	0516.0352	Special hose for NO ₂ /SO ₂ measurements Length 2.2 m	0554.7441
Additional box for system case	0516.0353		
Testo databus connection cable, 2 m	0449.0042		
Testo databus connection cable, 5 m	0449.0043		
Testo databus connection cable, 20 m	0449.0044		
(Other cable lengths avail. upon request)			
Replacement parts for analyser box:			
Replacement filter (yellow), 20 pieces	0554.3381		
Replacement filter with water stop (white), 10 pieces	0554.3380		

7. Ordering data

7.1 testo 350 M/XL

7.1.2 For additionally required measuring systems

Ordering data for system and accessories	Order no.	Ordering data for system and accessories	Order no.
testo 350, Control Unit		testo 350 XL analyser box and equipment	
Control Unit displays measurement data and controls the measuring system, incl. built-in printer, pressure measurement 80/200 hPa, 1 probe socket, programmable measurements and memory space for 250,000 readings, connection for Testo databus	0563 0353	testo 350 XL analyser box, equipped with O ₂ , CO (with switch-off and rinse function), NO, NO ₂ , differential pressure measurement, 2 temperature probe sockets, gas preparation, testo databus connection, automatic fresh air rinse with valve, integrated rechargeable battery, data memory, can be upgraded to max. 6 measurement modules (with H ₂ S, HC, SO ₂)	0563 0350
Touch screen with pen (available only with original order, not an upgrade) For easy input of characters and commands via display	0440 0559	CO _{low} measurement module, 0 to 500 ppm, highly accurate, instead of standard CO measurement module, built into analyser box	0440 3925
Spare thermal paper for printer (6 rolls)	0554 0569	NO _{low} measurement module, 0 to 200 ppm, highly accurate, instead of standard NO measurement module, built into analyser box	0440 3934
Barcode pen to read in measurement locations Quick and accurate allocation of reading to location	0554 0460	SO ₂ measurement module, built into analyser box	0440 3927
Barcode labels, self-adhesive (1,200 pieces) Marks location with barcode, printed using software	0554 0411	HC measurement module (nonburned hydrocarbons), built into analyser box	0440 3929
Adhesive pockets (50 pieces) for print-out, paper barcode labels...	0554 0116	H ₂ S measurement module, built into analyser box	0440 3930
IRDA interface, from hand-held measuring instrument to PC For direct online transfer of readings to PC	0440 0560	Measuring range extension for CO measurement module (dilution), built into analyser box, selectable dilution factors: 0, 2, 5, 10, 20, 40	0440 0555
Testo rechargeable battery pack NiMH for Control Unit, logger	0515 0097	Event trigger input, for starting and stopping measurement externally, built into analyser box	0440 3932
Mains unit 230 V, for measuring instrument (European plug)	0554 1084		
testo 350 M analyser box and equipment		Accessories for analyser boxes	
testo 350 M analyser box, with O ₂ , CO (with switch-off and rinse functions), gas preparation, diff. pressure meas., 2 temperature probe sockets, can be upgraded to max. 4 measurement modules (with NO/NO ₂ /SO ₂), testo databus connection, built-in rech. batt., data memory	0563 0351	Wall bracket, can be locked, for analyser box	0554 0203
CO _{low} measurement module, 0 to 500 ppm, highly accurate, instead of standard CO measurement module, built into analyser box	0440 3925	Carrying belt set for analyser box and hand-held instrument	0554 0434
NO measurement module, 0 to 3,000 ppm, built into analyser box	0440 3935	Transport case for analyser, probes and accessories	0516 0351
NO _{low} measurement module, 0 to 200 ppm, highly accurate, built into analyser box	0440 3928	Service case (aluminium), with drawer for accessories, for transport and protection during measurement	0516 0352
NO ₂ measurement module, built into analyser box	0440 3926	Additional box for system case 0516 0352, can be snapped on	0516 0353
SO ₂ measurement module, built into analyser box	0440 3927	ISO calibration certificate/flue gas	0520 0003
Fresh air valve, built into analyser box	0440 0557	Calculation of fuel-specific factors to accurately display calculated variables in deviating fuels (calculation for one fuel)	0991 0030
Measuring range extension for CO measurement module (dilution), built into analyser box, selectable dilution factors: 0, 2, 5, 10, 20, 40	0440 0555	Spare particle filter, pack of 20	0554 3381
		Hose set for flue gas discharge from analyser box, 5m long	0554 0451

Ordering data for accessories	Order no.	Ordering data for accessories	Order no.
testo 454 logger and accessories		Accessories for testo databus	
Logger, measures and saves (max. 250,000 readings), incl. 4 probe sockets, alarm output/event trigger input, stand/wall bracket	0577 4540	Mains unit, 230 V, to supply power to testo databus for use with Testo plug-in cards	0554 1145
Alarm/trigger cable	0554 0012	Terminal plug for testo databus only for logger	0554 0119
Bracket with lock for measurement data memory instrument theft protection	0554 1782	Connection cable, 2 m, for testo databus	0449 0042
Powerbox, connected to measuring system to increase field operating life for a battery-operated measuring system	0554 1045	Connection cable, 5 m, for testo databus	0449 0043
Mains unit for powerbox	0554 1143	Connection cable, 20 m, for testo databus	0449 0044
Analog output unit, 6 channels, 4 to 20 mA For output on an analog recorder or process control	0554 0845		Additional cable lengths upon request
Testo rechargeable battery pack NiMH for Control Unit, logger	0515 0097	PC software	
Recharger for Control Unit or logger (with 4 standard rechargeable batteries) Rechargeable batteries are recharged externally	0554 0110	ComSoft 3 for data management, incl. RS-232 connection cable Incl. database, analysis and graphics function, data analysis, trend curve	0554 0841
Mains unit 230 V, for instrument (European plug) For separate use of Control Unit	0554 1084	Testo PCMCIA plug-in card incl. Comsoft 3 software, cable for testo databus and adapter	0554 0590
		Galvanic isolation for RS-232 (connects measuring instrument to PC)	0554 0006

7. Ordering data







7.1 testo 350 M/XL





7.1.2 For additionally required measuring systems







Standard probes 335 mm long		Order no.	Industrial probes		Order no.
Flue gas probe, 335 mm immersion depth incl. probe stop, thermocouple NiCr-Ni (Ti) T/C Tmax 500 °C, 2.2 m hose, robust plug-in coupling		0600 7451	Adapter, non-heated		0600 7911
Options			Heated handle		0600 7920
Outer pipe with filter, Tmax. +800 °C, 335 mm long, for dusty flue gases		0440 7435	Extension pipe, +600 °C, 1 m long, stainless steel 1.4571		0600 7802
or:			Extension pipe +1,200 °C, 1 m long, material: Inconel 625		0600 7804
Heat-proof probe pipe, 335 mm long, Tmax +1,000 °C		0440 7437	Sampling pipe, +600 °C, 1 m long, material: stainless steel 1.4571		0600 7801
Hose, 5 m long		0440 7443	Sampling pipe, +1,200 °C, 1 m long, material: Inconel 625		0600 7803
Special hose for NO ₂ /SO ₂ measurements, 2.2 m long		0440 7442	Sampling pipe, +1,800 °C, 1 m long, material: Al-Oxide		0600 7805
Special hose for NO ₂ /SO ₂ measurements, 5 m long		0440 7445	Heated sampling pipe (230 V)		0600 7820
			Heated sampling pipe (115 V)		0600 7821
			Ceramic preliminary filter for dusty flue gases, Tmax +1,000 °C		0554 0710
			Filter fineness 20 µm, dust: 20 g/m ³ , can be screwed onto extension pipes, not onto sampling pipes		
			Gas sampling hose, 4 m, also suitable for NO ₂ /SO ₂		0554 3382
			Thermocouple, 1.2 m long, for flue gas temp. meas., Tmax. +1,000 °C		0430 0065
			Thermocouple, 2.2 m long, for flue gas temperature measurement, Tmax +1,000 °C	The length depends on the number of sampling and extension pipes used	0430 0066
			Thermocouple, 3.2 m long, for flue gas temperature measurement, Tmax. +1,000 °C		0430 0067
			Mounting flange, stainless steel, incl. quick-action chuck		0554 0760
Standard probes 700 mm long		Order no.	Ordering data for accessoires		Order no.
Flue gas probe, 700 mm immersion depth incl. probe stop, thermocouple NiCr-Ni (Ti) Tmax 500 °C, 2.2 m hose, robust plug-in coupling		0600 7452	Transport case for industrial probes, aluminium		0516 7900
Options					
Outer pipe with filter, Tmax. +800 °C, 700 mm long, for dusty flue gases		0440 7436			
or:					
Heat-proof probe pipe, 700 mm long, Tmax +1,000 °C		0440 7438			
Hose, 5 m long		0440 7444			
Special hose for NO ₂ /SO ₂ measurements, 2.2 m long		0440 7442			

7. Ordering data

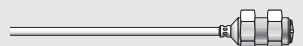
7.1 testo 350 M/XL 7.1.3 Suitable probes

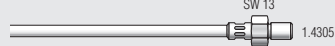
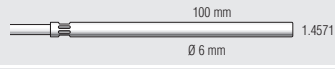
Selection of temperature probes	Illustration	Meas. range	Accuracy	t ₉₉	Conn.	Order no.
Ambient air probe, 300 mm immersion depth, with probe stop for separate measurement of ambient air temperature (e.g. systems with outside primary air intakes)		0... +100 °C		30 s		0600 9791
Mini ambient air probe, 60 mm immersion depth, with probe stop, magnetic clip, T _{max} +100 °C, for dual wall clearance temp. meas. in systems with outside primary air intakes		0... +100 °C		30 s		0600 9797
Mini ambient air probe, T _{max} +80 °C, for separate ambient air temperature measurement		0... +80 °C				0600 3692
Pipe wrap probe for pipes with diameter of up to 2", for flow/return temperature measurement in hydronic systems		-60... +130 °C	Class 2	5 s	Fixed cable	0600 4593
Spare meas. head for pipe wrap probe		-60... +130 °C	Class 2	5 s		0602 0092
Quick-action surface probe with spring-loaded thermocouple band for measurements in floor heating systems, radiators, insulation...		-200... +300 °C	Class 2	3 s	Plug-in head, connection cable 0430 0143 or 0430 0145 required	0604 0194

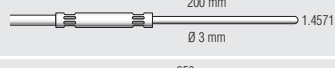
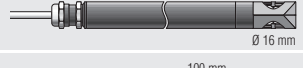
Additional probes	Illustration	Meas. range	t ₉₀	Other features	Order no.
Gas leak detection probe to detect leaks in gas heating systems		0... +10,000 ppm CH ₄	2 s	1st alarm limit: 200 ppm CH ₄ 2nd alarm limit: 10,000 ppm CH ₄ Alarm: optical display (LED) and audible signal (buzzer) triggered if alarm limit is exceeded	0632 1246
CO probe to measure CO level in ambient air		0... +500 ppm CO	35 s		0632 1247
CO ₂ probe measures indoor air quality and monitors the workplace. With plug-in head, connection cable 0430 0143 or 0430 0145 required		0... +1 Vol. % CO ₂ 0... +10,000 ppm CO ₂		±(50 ppm CO ₂ ±2% of reading) (0... +5,000 ppm CO ₂) ±(100 ppm CO ₂ ±3% of reading) (+5,001... +10,000 ppm CO ₂)	0632 1240 *1
Current/voltage cable (±1 V, ±10 V, 20 mA)		0... +1,000 mV 0... +10 V 0... +20 mA		±1 mV (0... +1,000 mV) ±0.01 V (0... +10 V) ±0.04 mA (0... +20 mA)	0554 0007
Mechanical rpm probe with plug-in head		+20... +20,000 rpm		Plug-in head, connection cable 0430 0143 or 0430 0145 required	0640 0340
 Included: 2 probe tips Ø 8 and Ø 12 mm 1 hollow cone Ø 8 mm 1 surface speed disc Ø 19 mm to measure rotational speed: rpm = rotational speed in mm/s					

Stationary probes	Illustration	Meas. range	Accuracy	t ₉₉	Order no.
Robust, quick-action surface probe, NiCr-Ni, with M14 x 1.5 thread, incl. 2 nuts for mounting, 2 m cable (PVC)		-50... +180 °C	Class 2	3 s	0628 6021
Universal probe, NiCr-Ni, for measurements in liquids and gases, 2 m cable (PVC), IP 42 connection socket		-200... +1100 °C	Class 1	2 s	0628 6004
Screw-in probe, Pt100, for measurements at hard-to-access points, M 6 thread, 2 m cable (PVC)		-10... +80 °C	Class A	70 s	0628 6014
Immersion probe, Pt100, for measurements in water and unclean environments, 2 m cable (silicone)		-50... +180 °C	Class A	70 s	0628 6003
Immersion probe, Pt100, for measurements in corrosive substances, 2 m cable (PTFE), IP 67		-50... +260 °C	Class A	50 s	0628 6008
Resistance thermometer, Pt100, for surface measurement, 2 m cable (silicone), IP 65		-30... +180 °C	Class A	150 s	0628 6016
Universal probe, Pt100, for measurements in liquids and gases, 2 m cable (PVC), IP 42		-50... +400 °C	Class A	15 s	0628 6044
Vane probe, Ø 16 mm, for stationary assembly, 3 m cable (PVC)		-30... +80 °C	±(0.2 m/s ±1% of reading) (+0.4... +40 m/s)		0628 0036 *3
Robust hot bulb probe, Ø 3 mm, for measurements in the lower velocity range, 2 m cable (PVC)		0... +10 m/s -20... +70 °C	±(0.03 m/s ±5% of reading) (0... +10 m/s)		0628 0035

Accessories for stationary probes	Order no.	Accessories for stationary probes	Order no.
Wall holder with screw-in connection for vane probe, Ø 16mm	0628 0037	Clamp screw connection (steel) with G 1/4" thread to attach temperature probes with Ø 6mm	0400 6166
Clamp screw connection (steel) with M 8 x 1 thread, to attach temperature probes with Ø 3mm	0400 6163		



*1: meets EN 61326-1: 1997

*3: meets EN 61326-1: 1997 in conjunction with Control Unit

7. Ordering data

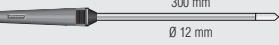
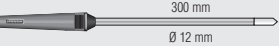
7.1 testo 350 M/XL 7.1.3 Suitable probes

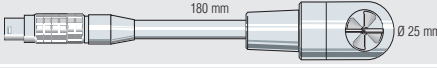
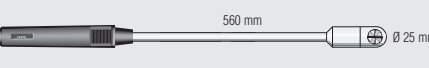
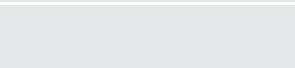
Selection of humidity probes	Illustration	Meas. range	Accuracy	Conn.	Order no.
Standard indoor air quality probe up to +70 °C		0... +100 %RH -20... +70 °C	±2 %RH (+2...+98 %RH) ±0.4 °C (-10... +50 °C) ±0.5 °C (-20... -10.1 °C) ±0.5 °C (+50.1... +70 °C)	12 s Plug-in head, connection cable 0430 0143 or 0430 0145 required	0636 9740 *3, 4
Robust humidity probe e.g. for measuring equilibrium moisture or for measurements in exhaust ducts to +120 °C		0... +100 %RH -20... +120 °C	±2 %RH (+2...+98 %RH) ±0.4 °C (-10... +50 °C) ±0.5 °C (-20... -10.1 °C) ±0.5 °C (+50.1... +120 °C)	30 s Plug-in head, connection cable 0430 0143 or 0430 0145 required	0636 2140 *1
Robust high temperature/humidity probe up to +180 °C		0... +100 %RH -20... +180 °C	±2 %RH (+2...+98 %RH) ±0.4 °C (+0.1... +50 °C) ±0.5 °C (-20... 0 °C) ±0.5 °C (+50.1... +180 °C)	30 s Plug-in head, connection cable 0430 0143 or 0430 0145 required	0628 0021 *1

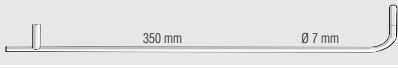
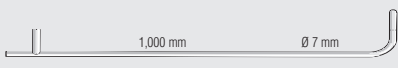
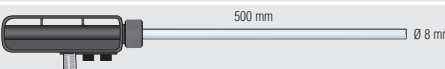
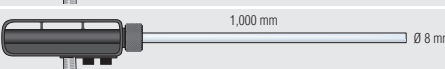
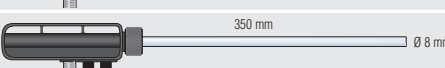
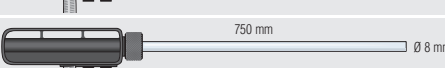
Selection of velocity, pressure probes	Illustration	Probe type	Meas. range	Accuracy	Order no.
Vane/temperature probe, Ø 16 mm, attachable to handle or telescopic handle		Vane Type K (NiCr-Ni)	+0.4... +60 m/s -30... +140 °C	±(0.2 m/s ±1% of reading) (+0.4... +60 m/s)	0635 9540 *3
Vane/temperature probe, Ø 25 mm, can be attached to handle or telescopic handle		Vane Type K (NiCr-Ni)	+0.4... +40 m/s -30... +140 °C	±(0.2 m/s ±1% of reading) (+0.4... +40 m/s)	0635 9640 *3
High temperature vane probe, Ø 25 mm, with handle for continuous measurements up to +350 °C		Vane Type K (NiCr-Ni)	+0.6... +20 m/s -40... +350 °C	±(0.3 m/s ±1% of reading) (+0.6... +20 m/s)	0635 6045 *3
Precision pressure probe, 100 Pa, measures differential pressure and velocities (in connection with pitot tube)		Differential pressure probe	0... +100 Pa	±(0.3 Pa ±0.5% of reading) (0... +100 Pa)	0638 1345 *1
Pressure probe, 10 hPa, measures differential pressure and velocities (in connection with pitot tube)		Differential pressure probe	0... +10 hPa	±0.03 hPa (0... +10 hPa)	0638 1445 *2
Pressure probe, 100 hPa, measures differential pressure and velocities (in connection with pitot tube)		Differential pressure probe	0... +100 hPa	±0.5% of reading (+20... +100 hPa) ±0.1 hPa (0... +20 hPa)	0638 1545 *1
Pitot tube, 350 mm long, stainless steel, measures flow velocity			Oper. temp. 0... +600 °C		0635 2145
Pitot tube, 1000 mm long, stainless steel, measures flow velocity			Oper. temp. 0... +600 °C		0635 2345
Pitot tube, stainless steel, 500 mm long, measures flow velocity incl. temperature		Type K (NiCr-Ni)	-40... +600 °C		0635 2140
Pitot tube, stainless steel, 1,000 mm long, measures flow velocity incl. temperature		Type K (NiCr-Ni)	-40... +600 °C		0635 2240
Pitot tube, stainless steel, 350 mm long, measures flow velocity incl. temperature		Type K (NiCr-Ni)	-40... +1,000 °C		0635 2041
Pitot tube, stainless steel, 700 mm long, measures flow velocity incl. temperature		Type K (NiCr-Ni)	-40... +1,000 °C		0635 2042

Accessories for velocity probes, pressure probes	Order no.
Professional telescopic handle for plug-in vane probes, max. 1 m long, extension on request	0430 0941
Extension for telescopic handle, 2 m long Please also order the 0409 0063 extension cable	0430 0942
Handle for plug-in vane probes	0430 3545
Magnetic holder for pressure probes	0554 0225
Hose connection set, incl. silicone hose and connection adapter For separate gas pressure measurement	0554 0315

Accessories for temperature, humidity, CO2 probes	Order no.
Cable, 1.5 m long, connects probe with plug-in head to meas. instrument PUR coating material	0430 0143
Cable, 5 m long, connects probe with plug-in head to measuring instrument PUR coating material	0430 0145
Extension cable, 5 m long, between plug-in head cable and instrument PUR coating material	0409 0063
Telescopic handle, max. 1 m, for probe with plug-in head Cable: 2.5 m long, PUR coating material	0430 0144
Control and humidity adjustment set 11.3 %RH/75.3 %RH incl. adapter for humidity probes	0554 0660
Telescopic handle, 340 - 800 mm long	0430 9715

*1: meets EN 61326-1 : 1997

*2: does not meet EN 61326-1: 1997 - does not meet EN 61326: 1997 / A1: 1998

*3: meets EN 61326-1 : 1997 in conjunction with Control Unit

*4: We recommend the use of a Teflon cap (0554 0756) for tough industrial applications.

7.2 **testo 454**

7.2.1 Measuring systems and accessories

7.2.2 Suitable probes

7. Ordering data

7.2 testo 454













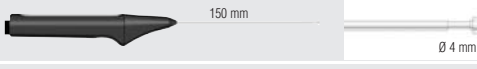

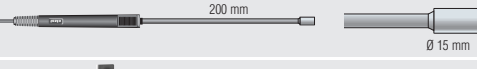
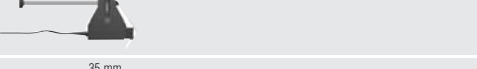
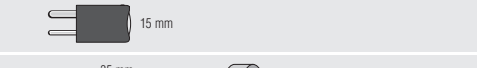
7.2.1 Measuring systems and accessories

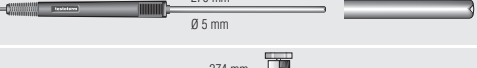
Ordering data for systems and accessories	Order no.
Control Unit + logger	
Control Unit displays measurement data and controls the measuring system, incl. built-in printer, pressure measurement 80/200 hPa, 1 probe socket, programmable measurements and memory space for 250,000 readings, connection for testo databus	0563 0353
Touch screen with pen (available only with original order, not an upgrade) For easy input of texts and values	0440 0559
Logger, measures and saves (max. 250,000 readings), incl. 4 probe sockets, alarm output/event trigger input, stand/wall bracket	0577 4540
Alarm/trigger cable	0554 0012
Recharger for Control Unit or logger (with 4 standard rechargeable batteries) Rechargeable batteries are recharged externally	0554 0110
Testo rechargeable battery pack NiMH for Control Unit, logger	0515 0097
Mains unit 230 V, for Control Unit, logger and analog output box For mains operation and to recharge testo rechargeable battery packs in instrument	0554 1084
Analog output box + powerbox	
Analog output box, 6 channels, 4 to 20 mA For output on an analog recorder or process control	0554 0845
Mains unit 230 V, for Control Unit, logger and analog output box	0554 1084
Power box, connected to measuring system to increase field operating life for a battery-operated measuring system	0554 1045
Mains unit for powerbox	0554 1143
testo databus	
Connection cable, 2 m, for testo databus	0449 0042
Connection cable, 5 m, for testo databus	0449 0043
Connection cable, 20 m, for testo databus	0449 0044
Mains unit, 230 V, to supply power to testo databus	0554 1145
Terminal plug for testo databus	0554 0119
Software	
ComSoft 3 for data management, incl. RS-232 connection cable Incl. database, analysis and graphics function, data analysis, trend curve	0554 0841
Testo PCMCIA plug-in card incl. Comsoft 3 software, cable for testo databus and adapter	0554 0590
Electrical isolation for RS-232 (connects measuring instrument to PC)	0554 0006

Ordering data for systems and accessories	Order no.
Accessories	
Barcode pen to read in measurement locations Quick and accurate allocation of reading to location	0554 0460
Barcode labels, self-adhesive (1,200 pieces) Marks location with barcode, printed using software	0554 0411
Adhesive pockets (50 pieces) for printout, paper barcode labels...	0554 0116
Spare thermal paper for printer (6 rolls)	0554 0569
Enhanced thermal paper for printer (6 rolls) Measurement data documentation legible for up to 10 years	0554 0568
Holder/theft-proof protection with lock for logger wall mounting device	0554 1782
Connection hose, silicone, 5 m long Max. load 700 hPa (mbar)	0554 0440
Case	
System case (aluminium) for measuring instrument, probes and accessories Probes in lid make it easy to find parts in case	0516 0410
Large system case (aluminium) for Control Unit, up to 6 loggers, probes and accessories 1 section for velocity probes, ample space in lid for probes and large section in base for accessories	0516 0420
Certificates	
ISO calibration certificate/pressure 5 points distributed evenly over meas. range of the object being tested from -1 to 20 bar	0520 0005
ISO calibration certificate/velocity Hot wire/vane anemometer, pitot tube; calibration points 5; 10; 15; 20 m/s	0520 0034
DKD calibration certificate/velocity Hot wire/vane anemometer, pitot tube; calibration points 2; 5; 10; 15; 20 m/s	0520 0204

7. Ordering data

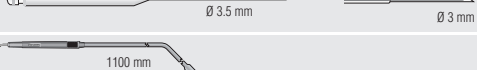
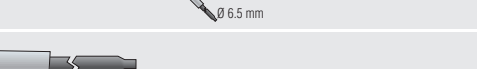
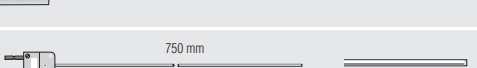
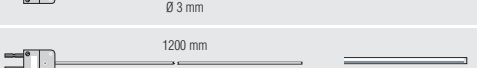
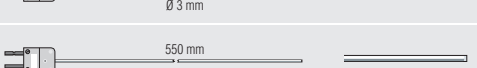
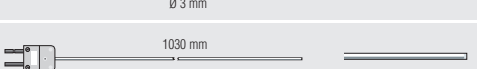

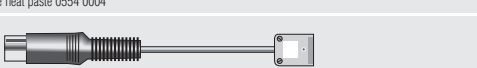
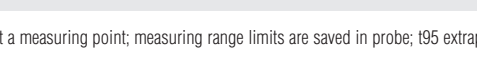



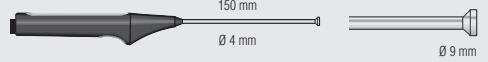
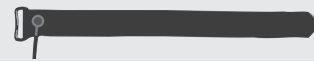

7.2 testo 454 7.2.2 Suitable probes

NiCr-Ni probes	Illustration	Meas. range	Accuracy	t99	Conn.	Part no.
Quick-action surface probe with sprung thermocouple strip, measuring range short-term to +500°C		-200... +300 °C	Class 2	3 s	Plug-in head, connection cable 0430 0143 or 0430 0145 required	0604 0194 0614 0194
Super quick-action surface probe, probe tip at 90° angle, with sprung thermocouple strip		-200... +300 °C	Class 2	3 s	Plug-in head, connection cable 0430 0143 or 0430 0145 required	0604 0994 0614 0994
Robust surface probe		-200... +600 °C	Class 1	25 s	Plug-in head, connection cable 0430 0143 or 0430 0145 required	0604 9993 0614 9993
Robust surface probe, at 90° angle, suitable for inaccessible places		-200... +600 °C	Class 1	25 s	Plug-in head, connection cable 0430 0143 or 0430 0145 required	0604 9893 0614 9893
Robust surface probe with sprung thermocouple strip for high temperature range up to +700°C		-200... +700 °C	Class 2	3 s	Fixed cable, coiled	0600 0394
Pipe wrap probe for pipes with diameter of up to 2", for flow/return temperature measurement in hydronic systems		-60... +130 °C	Class 2	5 s	Fixed cable	0600 4593
Spare meas. head for pipe wrap probe		-60... +130 °C	Class 2	5 s		0602 0092
Magnetic probe, adhesive power approx. 20 N, with magnets, for measurements on metal surfaces		-50... +170 °C	Class 2		Fixed cable	0600 4793
Magnetic probe, adhesive power approx. 10 N, with magnets, for higher temperatures, measures on metal surfaces		-50... +400 °C	Class 2		Fixed cable	0600 4893
Miniature surface probe for measurements on electronic components, small motors...		-200... +400 °C	Class 2	3 s	Fixed cable	0600 1494
Roller surface probe for measurements on rollers and rotating drums, max. circumferential velocity 18 to 400m/min		-50... +240 °C	Class 2		Fixed cable, coiled	0600 5093
Fast response immersion/penetration probe		-200... +400 °C	Class 1	3 s	Plug-in head, connection cable 0430 0143 or 0430 0145 required	0604 0293 0614 0293
Super quick-action immersion/penetration probe for measurements in liquids		-200... +600 °C	Class 1	1 s	Plug-in head, connection cable 0430 0143 or 0430 0145 required	0604 0493 0614 0493
Super quick-action immersion/penetration probe for high temperatures		-200... +1100 °C	Class 1	1 s	Plug-in head, connection cable 0430 0143 or 0430 0145 required	0604 0593 0614 0593
Super quick-action immersion/penetration probe for measurements in gases and liquids with a low-mass tip		-200... +600 °C	Class 1	1 s	Plug-in head, connection cable 0430 0143 or 0430 0145 required	0604 9794 0614 9794
Robust immersion/penetration probe made of V4A stainless steel, waterproof and oven-proof, e.g. for the food sector		-200... +400 °C	Class 1	3 s	Fixed cable	0600 2593
Smelting probe for measurements in non-ferrous melting baths, with exchangeable measuring tips		-200... +1250 °C	Class 1	60 s	Fixed cable	0600 5993
Spare measuring tip for smelting probe		-200... +1250 °C	Class 1	60 s		0363 1712
Plug-in measuring tip, 750mm long, flexible, for high temperatures, outer casing: stainless steel 1.4541		-200... +900 °C	Class 1	4 s	Please order handle with Part no. 0600 5593	0600 5393
Plug-in measuring tip, 1200 mm long, flexible, for high temperatures, outer casing: stainless steel 1.4541		-200... +900 °C	Class 1	4 s	Please order handle with Part no. 0600 5593	0600 5493
Plug-in measuring tip, 550mm long, flexible, for high temperatures, outer casing: Inconel 2.4816		-200... +1100 °C	Class 1	4 s	Please order handle with Part no. 0600 5593	0600 5793
Plug-in measuring tip, 1030mm long, flexible, for high temperatures, outer casing: Inconel 2.4816		-200... +1100 °C	Class 1	4 s	Please order handle with Part no. 0600 5593	0600 5893
Thermocouple, made of fibre-glass insulated thermal pipes, pack of 5 Insulation: twin conductor, flat, oval, covered and covered with fibre-glass, both conductors are wrapped together with fibre-glass and soaked with lacquer, please order adapter 0600 1693		-200... +400 °C	Class 1	5 s	Please order adapter 0600 1693	0644 1109
Adhesive thermocouple, pack of 2, carrier material: aluminium foil Is fixed at the measuring point using conventional adhesives or silicone heat paste 0554 0004		-200... +200 °C	Class 1		Please order adapter 0600 1693	0644 1607
Adapter to connect NiCr-Ni thermocouples and probes with open wire ends					Fixed cable	0600 1693

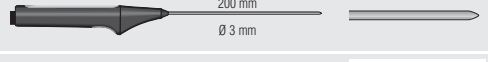
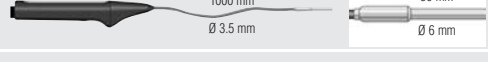
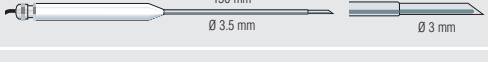
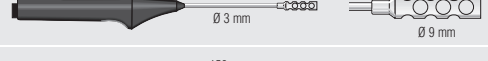
*with EEPROM: Precision adjustment for each probe at a measuring point; measuring range limits are saved in probe; t95 extrapolation; surface allowance in surface probe can be adapted to measuring task

7. Ordering data



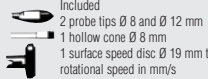



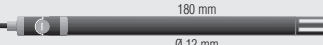

7.2 testo 454 7.2.2 Suitable probes

NTC probes		Illustration	Meas. range	Accuracy	t99	Conn.	Part no.
Highly accurate air probe for air and gas temperature measurements with bare, mechanically protected sensor		 150 mm Ø 9 mm	-40... +130 °C	To UNI curve	60 s	Fixed cable	0610 9714
Pt100 probes		Illustration	Meas. range	Accuracy	t99	Conn.	Part no.
Robust surface probe		 150 mm Ø 4 mm	-50... +400 °C	Class B	40 s	Plug-in head, connection cable 0430 0143 or 0430 0145 required	0604 9973 0628 0018
Velcro probe for pipes with diameter of max. 100 mm			-50... +150 °C	Class B	40 s	Fixed cable	0628 0019
Standard immersion/penetration probe		 200 mm Ø 3 mm	-200... +400 °C	Class A	20 s	Plug-in head, connection cable 0430 0143 or 0430 0145 required	0604 0273
Standard immersion/penetration probe		 200 mm Ø 3 mm	-200... +600 °C	Class A	20 s	Plug-in head, connection cable 0430 0143 or 0430 0145 required	0604 0274
Highly accurate immersion/penetration probe		 200 mm Ø 3 mm	-100... +400 °C	1/10 Class B (0 to 100°C) 1/5 Class B (rem. range) to EN 60751	30 s	Plug-in head, connection cable 0430 0143 or 0430 0145 required	0628 0015
Flexible precision immersion probe, cable heat-proof up to +300°C		 1000 mm Ø 3.5 mm	-100... +300 °C	1/10 Class B (0 to 100°C) 1/5 Class B (rem. range) to EN 60751	80 s	Plug-in head, connection cable 0430 0143 or 0430 0145 required	0628 0016
Robust immersion/penetration probe with sharpened measuring tip, waterproof and oven-proof		 150 mm Ø 3.5 mm	-200... +400 °C	Class A	30 s	Fixed cable	0604 2573
Standard air probe		 150 mm Ø 3 mm	-200... +600 °C	Class A	75 s	Plug-in head, connection cable 0430 0143 or 0430 0145 required	0604 9773
Precision air probe		 150 mm Ø 3 mm	-100... +400 °C	1/10 Class B (0 to 100°C) 1/5 Class B (rem. range) to EN 60751	75 s	Plug-in head, connection cable 0430 0143 or 0430 0145 required	0628 0017
Other temperature probes		Illustration	Meas. range	Accuracy	t99	Conn.	Part no.
Globe thermometer to measure radiant heat		 Ø 150 mm	0... +120 °C	±0.5 °C (0... +49.9 °C) ±1 °C (+50... +120 °C)		Fixed cable	0554 0670
Infrared surface probe for fast non-contact temperature measurement on live, inaccessible and rotating parts			-18... +260 °C	±2% of mv (+100.1... +260 °C) ±2 °C (-18... +100 °C)	2 s	Fixed cable, coiled	0600 0750
More probes		Illustration	Meas. range	Accuracy	Conn.	Part no.	
CO probe to measure CO level in ambient air		 190 mm Ø 25 mm	0... +500 ppm CO	±5% of mv (+100.1... +500 ppm CO) ±5 ppm CO (0... +100 ppm CO)	Fixed cable	0632 1247	
CO2 probe measures indoor air quality and monitors the workplace. With plug-in head, connection cable 0430 0143 or 0430 0145 required			0... +1 Vol. % CO2 0... +10000 ppm CO2	±(50 ppm CO2 ±2% of mv) (0... +5000 ppm CO2) ±(100 ppm CO2 ±3% of mv) (+5001... +10000 ppm CO2)	Plug-in head, connection cable 0430 0143 or 0430 0145 required	0632 1240	
Mechanical rpm probe with plug-in head			+20... +20000 rpm	± 1 digit	Plug-in head, connection cable 0430 0143 or 0430 0145 required	0640 0340	
Included 2 probe tips Ø 8 and Ø 12 mm 1 hollow cone Ø 8 mm 1 surface speed disc Ø 19 mm to measure rotational speed: rpm = rotational speed in mm/s							
Current/voltage cable (±1 V, ±10 V, 20 mA)			0... +1000 mV 0... +10 V 0... +20 mA	±1 mV (0... +1000 mV) ±0.01 V (0... +10 V) ±0.04 mA (0... +20 mA)			0554 0007
Accessories for temperature probes		Part no.	Accessories for temperature probes		Part no.		
Cable, 1.5 m long, connects probe with plug-in head to meas. instrument		0430 0143	Glass pipe for immersion/penetration probe to protect from corrosive substances		0554 7072		
PUR coating material			For probes with Part nos. 0604 0273 and 0628 0015				
Cable, 5 m long, connects probe with plug-in head to measuring instrument		0430 0145	Silicone heat paste (14g), T _{max} = +260°C		0554 0004		
PUR coating material			Improves heat transfer in surface probes				
Extension cable, 5 m long, between plug-in head cable and instrument		0409 0063					
PUR coating material							
Telescopic handle, max. 1 m, for probe with plug-in head		0430 0144					
Cable: 2.5 m long, PUR coating material							
Handle for plug-in measuring tip		0600 5593					

*with EEPROM: Precision adjustment for each probe at a measuring point; measuring range limits are saved in probe; t95 extrapolation; surface allowance in surface probe can be adapted to measuring task

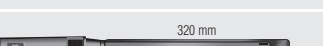
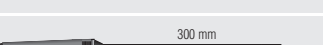
7. Ordering data

7.2 testo 454 7.2.2 Suitable probes

Description	Illustration	Meas. range	Accuracy	190	Conn.	Part no.
Standard indoor air quality probe up to +70°C		0... +100 %RH -20... +70 °C	±2 %RH (+2... +98 %RH) ±0.4 °C (-10... +50 °C) ±0.5 °C (-20... -10.1 °C) ±0.5 °C (+50.1... +70 °C)	12 s	Plug-in head, connection cable 0430 0143 or 0430 0145 required	0636 9740 *3, 4
Duct humidity/temperature probe, can be connected to telescopic handle <small>Telescopic handle 0430 9715, see Ordering data for Accessories</small>		0... +100 %RH -20... +70 °C	±2 %RH (+2... +98 %RH) ±0.4 °C (-10... +50 °C) ±0.5 °C (-20... -10.1 °C) ±0.5 °C (+50.1... +70 °C)	12 s	Fixed cable	0636 9715 *3
Highly accurate reference humidity/temp. probe		0... +100 %RH -20... +70 °C	±1 %RH (+10... +90 %RH) ±2 %RH (0... +9.9 %RH) ±2 %RH (+90.1... +100 %RH) ±0.4 °C (-10... +50 °C) ±0.5 °C (-20... -10.1 °C) ±0.5 °C (+50.1... +70 °C)	12 s	Plug-in head, connection cable 0430 0143 or 0430 0145 required	0636 9741 *1
Humidity/temperature probe		-20... +70 °C	±0.4 °C (+0.1... +50 °C) ±0.5 °C (-20... 0 °C) ±0.5 °C (+50.1... +70 °C)		Plug-in head, connection cable 0430 0143 or 0430 0145 required	0636 9742 *1
Flexible humidity probe with mini module for meas. e.g. on material testing rigs, module cable length 1500mm, probe tip 50x19x7mm		0... +100 %RH -20... +125 °C	±2 %RH (+2... +98 %RH) ±0.4 °C (-10... +50 °C) ±0.5 °C (-20... -10.1 °C) ±0.5 °C (+50.1... +125 °C)	20 s	Plug-in head, connection cable 0430 0143 or 0430 0145 required	0628 0013 *1
Sword probe for measuring humidity and temperature in stacked material		0... +100 %RH -20... +70 °C	±2 %RH (+2... +98 %RH) ±0.4 °C (-10... +50 °C) ±0.5 °C (-20... -10.1 °C) ±0.5 °C (+50.1... +70 °C)	12 s	Plug-in head, connection cable 0430 0143 or 0430 0145 required	0636 0340 *1
Robust humidity probe e.g. for measuring equilibrium moisture or for measurements in exhaust ducts to +120°C		0... +100 %RH -20... +120 °C	±2 %RH (+2... +98 %RH) ±0.4 °C (-10... +50 °C) ±0.5 °C (-20... -10.1 °C) ±0.5 °C (+50.1... +120 °C)	30 s	Plug-in head, connection cable 0430 0143 or 0430 0145 required	0636 2140 *1
Robust high temperature/humidity probe up to +180°C		0... +100 %RH -20... +180 °C	±2 %RH (+2... +98 %RH) ±0.4 °C (+0.1... +50 °C) ±0.5 °C (-20... 0 °C) ±0.5 °C (+50.1... +180 °C)	30 s	Plug-in head, connection cable 0430 0143 or 0430 0145 required	0628 0021 *1
Flexible humidity probe (does not retain shape) for measurements in inaccessible places		0... +100 %RH -20... +180 °C	±2 %RH (+2... +98 %RH) ±0.4 °C (+0.1... +50 °C) ±0.5 °C (-20... 0 °C) ±0.5 °C (+50.1... +180 °C)	30 s	Plug-in head, connection cable 0430 0143 or 0430 0145 required	0628 0022 *1
Standard pressure dew point probe for measurements in compressed air systems		0... +100 %RH -30... +50 °C tpd	±0.9 °C tpd (+0.1... +50 °C tpd) ±1 °C tpd (-4.9... 0 °C tpd) ±2 °C tpd (-9.9... -5 °C tpd) ±3 °C tpd (-19.9... -10 °C tpd) ±4 °C tpd (-30... -20 °C tpd)	300 s	Plug-in head, connection cable 0430 0143 or 0430 0145 required	0636 9840 *2
Precision pressure dew point probe for measurements in compressed air systems incl. cert. with test point -40°C tpd		0... +100 %RH -60... +50 °C tpd	±0.8 °C tpd (-4.9... +50 °C tpd) ±1 °C tpd (-9.9... -5 °C tpd) ±2 °C tpd (-19.9... -10 °C tpd) ±3 °C tpd (-29.9... -20 °C tpd) ±4 °C tpd (-40... -30 °C tpd)	300 s	Plug-in head, connection cable 0430 0143 or 0430 0145 required	0636 9841 *2
Flexible humidity probe (retains shape) for measurements at inaccessible points		0... +100 %RH -20... +140 °C	±2 %RH (+2... +98 %RH) ±0.4 °C (-10... +50 °C) ±0.5 °C (-20... -10.1 °C) ±0.5 °C (+50.1... +140 °C)	30 s	Plug-in head, connection cable 0430 0143 or 0430 0145 required	0628 0014 *1

*1: meets EN 61326-1 : 1997

*2: does not meet EN 61326-1: 1997 - does not meet EN 61326: 1997 / A1: 1998











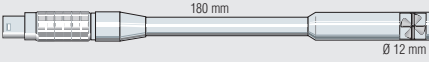

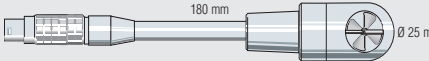

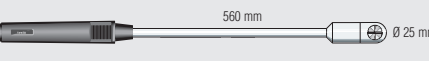

*3: meets EN 61326-1 : 1997 in conjunction with Control Unit

*4: We recommend the use of a Teflon cap (0554 0756) for tough industrial applications.

Accessories: Humidity probes	Part no.
Cable, 1.5 m long, connects probe with plug-in head to meas. instrument	0430 0143
Cable, 5 m long, connects probe with plug-in head to measuring instrument	0430 0145
PUR coating material	
Extension cable, 5 m long, between plug-in head cable and instrument	0409 0063
PUR coating material	
Telescopic handle, max. 1 m, for probe with plug-in head	0430 0144
Cable: 2.5 m long, PUR coating material	
Telescopic handle, 340 - 800mm long	0430 9715
Control and humidity adjustment set 11.3%RH/75.3%RH incl. adapter for humidity probes	0554 0660
Control and storage humidity (33%RH) for humidity probes	0554 0636
Metal protection cage, Ø 21 mm for humidity probes	0554 0665
For velocities of less than 10 m/s	
Metal protection cage, Ø 12 mm for humidity probes	0554 0755
For velocities of less than 10 m/s	
Wire mesh filter, Ø 21 mm, for metal protection cage and plastic cap	0554 0667
Protects from dirt and damage. Applications: meteorology, splashwater, condensation	
Cap with wire mesh filter, Ø 12 mm	0554 0757
Teflon sintered filter, Ø 21 mm, for corrosive substances	0554 0666
High humidity range (long-term measurements), high velocities	
Teflon sintered filter, Ø 12 mm, for corrosive substances	0554 0756
High humidity range (long-term measurements), high velocities	
Stainless steel sintered cap, Ø 21 mm, can be screwed onto humidity probe	0554 0640
Protection in case of high mechanical load and high velocities	
Stainless steel sintered cap, Ø 12 mm, is screwed onto humidity probe	0554 0647
For measurements at high velocity speeds or in dirt ingressed air	

7. Ordering data

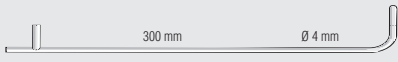
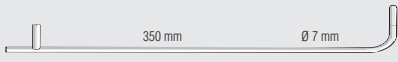
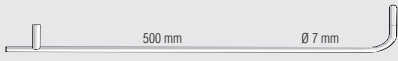
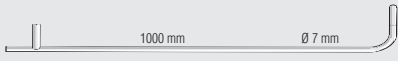
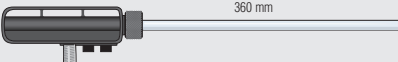
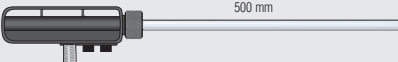
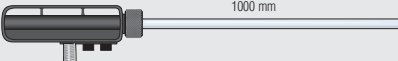

7.2 testo 454 7.2.2 Suitable probes

Description	Illustration	Probe type	Meas. range	Accuracy	Part no.
Vane probe, Ø 12 mm, can be attached to handle or telescopic handle		Vane	+0.6... +20 m/s Oper. temp. -30... +140 °C	±(0.2 m/s ±1% of mv) (+0.6... +20 m/s)	0635 9443
Vane/temperature probe, Ø 16 mm, attachable to handle or telescopic handle		Vane Type K (NiCr-Ni)	+0.4... +60 m/s -30... +140 °C	±(0.2 m/s ±1% of mv) (+0.4... +60 m/s)	0635 9540
Vane/temperature probe, Ø 25 mm, can be attached to handle or telescopic handle		Vane Type K (NiCr-Ni)	+0.4... +40 m/s -30... +140 °C	±(0.2 m/s ±1% of mv) (+0.4... +40 m/s)	0635 9640
Bendable vane probe (can be bent by 90°), Ø 60 mm, attachable to handle or telescopic handle, for measurements on ventilation outlets		Vane	+0.25... +20 m/s Oper. temp. 0... +60 °C	±(0.1 m/s ±1.5% of mv) (+0.25... +20 m/s)	0635 9440
Bendable vane probe (can be bent by 90°), Ø 100 mm, attachable to handle or telescopic handle, for measurements on ventilation outlets		Vane	+0.2... +15 m/s Oper. temp. 0... +60 °C	±(0.1 m/s ±1.5% of mv) (+0.2... +15 m/s)	0635 9340
Affordable, robust hot bulb probe, Ø 3 mm, for measurements in the lower velocity range, with handle		Hot bulb NTC	0... +10 m/s -20... +70 °C	±(0.03 m/s ±5% of mv) (0... +10 m/s)	0635 1549
Robust hot bulb probe, Ø 3 mm, with handle and telescopic handle for measurements in the lower velocity range		Hot bulb NTC	0... +10 m/s -20... +70 °C	±(0.03 m/s ±5% of mv) (0... +10 m/s)	0635 1049
Quick-action hot wire probe, Ø 10 mm, with telescopic handle, for measurements in the lower velocity range with direction recognition		Hot wire NTC	0... +20 m/s -20... +70 °C	±(0.03 m/s ±4% of mv) (0... +20 m/s)	0635 1041
Shell anemometer, 3 m cable, for meteorological wind measurement		Vane	+0.7... +30 m/s	±(0.3 m/s ±5% of mv) (+0.7... +30 m/s)	0635 9045
High temperature vane probe, Ø 25 mm, with handle for continuous measurements up to +350°C		Vane Type K (NiCr-Ni)	+0.6... +20 m/s -40... +350 °C	±(0.3 m/s ±1% of f.v.) (+0.6... +20 m/s)	0635 6045
Precision pressure probe, 100 Pa, measures differential pressure and velocities (in connection with Pitot tube)		Differential pressure probe	0... +100 Pa	±(0.3 Pa ±0.5% of mv) (0... +100 Pa)	0638 1345
Pressure probe, 10 hPa, measures differential pressure and velocities (in connection with Pitot tube)		Differential pressure probe	0... +10 hPa	±0.03 hPa (0... +10 hPa)	0638 1445
Pressure probe, 100 hPa, measures differential pressure and velocities (in connection with Pitot tube)		Differential pressure probe	0... +100 hPa	±0.5% of mv (+20... +100 hPa) ±0.1 hPa (0... +20 hPa)	0638 1545
Pressure probe, 2000 hPa, measures absolute pressure		Absolute pressure probe	0... +2000 hPa	±5 hPa (0... +2000 hPa)	0638 1645
Low pressure probe, refrigerant-proof stainless steel, without cable	Plug-in head, connection cable 0409 1745 required 	Screw-in thread 7/16" UNF Low pressure probe	-1... +10 bar	±1% of f.v. (-1... +10 bar) Overload ±32 bar (-1... +10 bar)	0638 1740
High pressure probe, refrigerant-proof stainless steel, without cable	Plug-in head, connection cable 0409 1745 required 	Screw-in thread 7/16" UNF High pressure probe	0... +30 bar	±1% of f.v. (0... +30 bar) Overload ±70 bar (0... +30 bar)	0638 1840
Pitot tube, 300 mm long, stainless steel, measures velocity in connection with pressure probes 0638 1345/.1445/.1545			Oper. temp. 0... +600 °C		0635 2245
Pitot tube, 350 mm long, stainless steel, measures velocity flow in connection with pressure probes 0638 1345/.1445/.1545			Oper. temp. 0... +600 °C		0635 2145
Pitot tube, 500 mm long, stainless steel, measures velocity in connection with pressure probes 0638 1345/.1445/.1545			Oper. temp. 0... +600 °C		0635 2045
Pitot tube, 1000 mm long, stainless steel, measures velocity in connection with pressure probes 0638 1345/.1445/.1545			Oper. temp. 0... +600 °C		0635 2345
Pitot tube, stainless steel, 360 mm long, measures velocity with temperature, for pressure probes 0638 1345/.1445/.1545		Type K (NiCr-Ni)	-40... +600 °C		0635 2040
Pitot tube, stainless steel, 500 mm long, measures velocity with temperature, for pressure probes 0638 1345/.1445/.1545		Type K (NiCr-Ni)	-40... +600 °C		0635 2140
Pitot tube, stainless steel, 1000 mm long, measures velocity with temperature, for pressure probes 0638 1345/.1445/.1545		Type K (NiCr-Ni)	-40... +600 °C		0635 2240
3-function probe for simultaneous measurement of temperature, humidity and velocity. With plug-in head, 0430 0143 or 0430 0145 connection cable required		Hot bulb Testo humid. sensor, capacitive NTC	0... +10 m/s 0... +100 %RH -20... +70 °C	±(0.03 m/s ±5% of mv) (0... +10 m/s) ±2 %RH (+2... +98 %RH) ±0.4 °C (0... +50 °C) ±0.3 °C (-20... 0 °C) ±0.3 °C (+50... +70 °C)	0635 1540
Comfort level probe for measuring turbulence levels, with telescope and stand. Fulfills DIN 1946 Part 2 or VDI 2080 requirements		Hot wire NTC	0... +5 m/s 0... +50 °C	±(0.03 m/s ±4% of mv) (0... +5 m/s) ±0.3 °C (0... +50 °C)	0628 0009

7. Ordering data

7.2 testo 454 7.2.2 Suitable probes

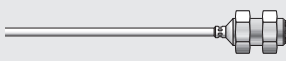
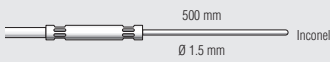
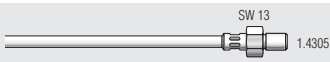
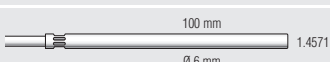
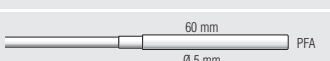
Accessories: Velocity, pressure, 3-function probes	Part no.	Accessories: Velocity, pressure, 3-function probes	Part no.
Professional telescopic handle for plug-in vane probes, max. 1 m long, extension on request	0430 0941	Connection cable for pressure probes 0638.1740 and 0638.1840	0409 1745
Extension for telescopic handle, 2 m long Please also order the 0409 0063 extension cable	0430 0942	Adapter for pressure probes, 1/2" outer thread, 1/4" inner thread	0699 3127
Handle for plug-in vane probes	0430 3545	Cover plugs for test holes (50 off)	0554 4001
Swan neck, flexible connection between probe and instrument	0430 0001	Adapter for humidity adjustment of 3-function probe 0635 1540 Order with adjustment set	0554 0661
Extension cable, 5 m long, between plug-in head cable and instrument PUR coating material	0409 0063	testovent 410, volume flow funnel, Ø 340mm/330 x 330mm, incl. case	0554 0410
Magnetic probe holder for vane probes	0554 0430	testovent 415, volume flow funnel, Ø 210mm/190x190mm, incl. case	0554 0415
Connection hose, silicone, 5m long Silicone hose connects Pitot tube and pressure probe, 5 m long	0554 0440		
Magnetic holder for pressure probes For pressure probes 0638 1345/.1445/.1545/.1645	0554 0225		

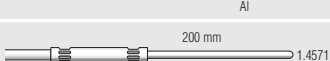
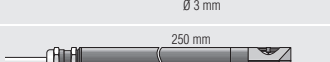
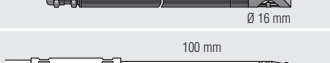
Stationary probes	Illustration	Meas. range	Accuracy	t ₉₉	Part no.
Robust, quick-action surface probe, NiCr-Ni, with M14 x 1.5 thread, incl. 2 nuts for mounting, 2 m cable (PVC)		-50... +180 °C	Class 2	3 s	0628 6021
Universal probe, NiCr-Ni, for measurements in liquids and gases, 2 m cable (PVC), IP 42 connection socket		-200... +1100 °C	Class 1	2 s	0628 6004
Screw-in probe, Pt100, for measurements at hard-to-access points, M 6 thread, 2 m cable (PVC)		-10... +80 °C	Class A	70 s	0628 6014
Immersion probe, Pt100, for measurements in water and unclean environments, 2 m cable (silicone)		-50... +180 °C	Class A	70 s	0628 6003
Immersion probe, Pt100, for measurements in corrosive substances, 2 m cable (PTFE), IP 67		-50... +260 °C	Class A	50 s	0628 6008
Resistance thermometer, Pt100, for surface measurement, 2 m cable (silicone), IP 65		-30... +180 °C	Class A	150 s	0628 6016
Universal probe, Pt100, for measurements in liquids and gases, 2m cable (PVC), IP 42		-50... +400 °C	Class A	15 s	0628 6044
Vane probe, Ø 16 mm, for stationary assembly, 3 m cable (PVC)		-30... +80 m/s	±(0.2 m/s ±1% of mv) (+0.4... +60 m/s)		0628 0036
Robust hot bulb probe, Ø 3 mm, for measurements in the lower velocity range, 2m cable (PVC)		0... +10 m/s -20... +70 °C	±(0.03 m/s ±5% of mv) (0... +10 m/s)		0628 0035

Accessories for stationary probes	Part no.	Accessories for stationary probes	Part no.
Wall holder with screw-in connection for vane probe, Ø 16mm	0628 0037	Clamp screw connection (steel) with G 1/4" thread, to attach temperature probes with Ø 6mm	0400 6166
Clamp screw connection (steel) with M 8x1 thread, to attach temperature probes with Ø 3mm	0400 6163		

8. Technical data

8.1 Logger

8.2 Analyser box

8. Technical data

8.2 Analyser box

Technical data for testo 350 M, testo 350 XL analysis box

Probe type	O2 measurement	CO (H2 compensated)	COlow meas. (H2 compensated)	CO2	NO meas. (option for testo 350 M)	NOlow measurement	NO2 measuring module (option for testo 350 M)	SO2 measurement	CO2 measurement (IR)
Meas. range	0... +25 Vol.% O2	0... +10000 ppm CO	0... +500 ppm CO	0... CO2max Vol.% CO2	0... +3000 ppm NO	0... +300 ppm NO	0... +500 ppm NO2	0... +5000 ppm SO2	0... 50Vol.% CO2
Accuracy ± 1 digit	±0.8% of f.v. (0... +25 Vol.% O2)	±5% of mv (+100... +2000 ppm CO) ±10% of mv (+2001... +10000 ppm CO) ±10 ppm CO (0... +99 ppm CO)	±5% of mv (+40... +500 ppm CO) ±2 ppm CO (0... +39.9 ppm CO)	Calculated from O2	±5% of mv (+100... +1999.9 ppm NO) ±10% of mv (+2000... +3000 ppm NO) ±5 ppm NO (0... +99 ppm NO)	±5% of mv (+40... +300 ppm NO) ±2 ppm NO (0... +39.9 ppm NO)	±5% of mv (+100... +500 ppm NO2) ±5 ppm NO2 (0... +99.9 ppm NO2)	±5% of mv (+100... +2000 ppm SO2) ±10% of mv (+2001... +5000 ppm SO2) ±5 ppm SO2 (0... +99 ppm SO2)	±0.3Vol.% + 1% v. Mw. (0... 25 Vol.% CO2) ±0.5Vol.% + 1.5% v. Mw. (>25... 50 Vol.% CO2)
Resolution	0.1 Vol.% O2 (0... +25 Vol.% O2)	1 ppm CO (0... +10000 ppm CO)	0.1 ppm CO (0... +500 ppm CO)	0.01 Vol.% CO2	1 ppm NO (0... +3000 ppm NO)	0.1 ppm NO (0... +300 ppm NO)	0.1 ppm NO2 (0... +500 ppm NO2)	1 ppm SO2 (0... +5000 ppm SO2)	0.01 Vol.% CO2 (0... 25 Vol.%) 0.1 Vol.% CO2 (>25 Vol.%)
Reaction time	20 s	40 s	40 s	20 s	30 s	30 s	40 s	30 s	< 10sec
Reaction type	t95	t90	t90	t95	t90	t90	t90	t90	t90

Probe type	Efficiency	Flue gas loss	Differential pressure 1	Differential pressure 2	Velocity	Temperature measurement			
Meas. range	0... +120 %	-20... +99.9 % qA	-200... +200 hPa	-40... +40 hPa	0... +40 m/s	-40... +1200 °C			
Accuracy ± 1 digit			±1.5% of mv (-50... -200 hPa) ±1.5% of mv (+50... +200 hPa) ±0.5 hPa (-49.9... +49.9 hPa)	±1.5% of mv (-40... -3 hPa) ±1.5% of mv (+3... +40 hPa) ±0.03 hPa (-2.99... +2.99 hPa)		±0.5% of mv (+100... +1200 °C) ±0.5 °C (-40... +99.9 °C)			
Resolution	0.1 % (0... +120 %)	0.1 % qA (-20... +99.9 % qA)	0.1 hPa (-200... +200 hPa)	0.01 hPa (-40... +40 hPa)	0.1 m/s (0... +40 m/s)	0.1 °C (-40... +1200 °C)			
Reaction time									
Reaction type									

Dimensions	395x275x95 mm	Additional technical data: Memory: 250 000 readings Power supply: Via integrated mains unit (90 V to 260 V, 47 to 63 Hz) or exchangeable rechargeable batteries Electrical power required: 0.5 A (110 V AC), 0.3 A (230 V AC) Dew point calculation: 0 to 99°C td Maximum positive pressure: 50 hPa (500 mm water column) Maximum negative pressure: 200 hPa (2000 mm water column) Pump flow: 0.8 m/s with flow monitoring Max. dust load: 20 g/m ³ dust in flue gas Max. humidity load: +70°C Dew point temperature at inlet			Measuring range extension (dilution) for CO: dilution factors 0, 2, 5, 10, 20, 40 Dilution gas: Fresh air or N2 Accuracy: Reading plus max. 2% Event trigger socket testo 350XL: Voltage: 5 to 12 Volt (ascending or descending edge) Impulse width >1 s Load: 5 V/max. 5 mA, 12 V/max. 40 mA		Warranty: Analysers: 2 years (excluding working parts e.g. measuring cells) CO/NO/NO2/SO2/H2S/HC/CO2 measuring cell: 1 year O2 measuring cell: 1.5 years		
------------	---------------	---	--	--	---	--	---	--	--

Additional technical data only for testo 350 XL analysis box

Fühlertyp	H2S measurement	
Meas. range	0... +300 ppm	
Accuracy ± 1 Digit	±5% of mv (+40... +300 ppm) ±2 ppm (0... +39.9 ppm)	
Resolution	0.1 ppm (0... +300 ppm)	
Reaction time	35 sec	
Reaction type	t90	

Additional technical data:
Event trigger socket: 5 bis 12 V (ascending or descending edge)

Technical data, HC module

Parameter	Methane	Propane	Butane
Meas. range ¹	100 to 40,000 ppm	100 to 21,000 ppm	100 to 18,000 ppm
Accuracy	< 400 ppm (100...4000 ppm) < 10 % of mv. (>4000 ppm)	< 400 ppm (100...4000 ppm) < 10 % of mv. (>4000 ppm)	< 400 ppm (100...4000 ppm) < 10 % of mv. (>4000 ppm)
Resolution	10 ppm	10 ppm	10 ppm
Min. O2 requirement in flue gas	2% + (2 x mv. methane)	2% + (5 x mv. propane)	2% + (6.5 x mv. butane)
Reaction time t90	< 40 sec.	< 40 sec.	< 40 sec.
Response factor ²	1	1.5	2

¹ Lower explosion limit (LEL) must be upheld.

² The HC module is factory adjusted to methane.
The user can adjust the module to another gas.

Notes on HC module technical data

- After switching on the measuring instrument, it is recommended that you again zero by using the (function key **Zeroise**). Frequently recalibrate even during long-term measurements in order to prevent "drifting" of the HC sensor.
- Because of the measuring principle (heat effect), the sensor must receive sufficient amounts of oxygen at all times, otherwise the module will be damaged beyond repair.
- The concentration of oxygen must be at 2 % as well as contain the required amount of oxygen for converting the hydrocarbons (see table). The testo 350 automatically switches off the HC sensor when the O₂ concentration level falls below 2 %.
- The module is adjusted to measuring methane at 5,000 ppm. The module must be re-adjusted to measure other gases such as ethane, propane, butane...or other concentrations.
- The HC module can also be destroyed when subjected to flue gas with higher concentrations of silicone, H₂S, and sulphur-containing hydrocarbons.

Caution!

The HC module must not be used for:

- **Measuring explosive or ignitable gas mixtures.**
- **Measuring gases which can form an ignitable mixture when exposed to air.**
- **Measuring alcohol vapours and other unsaturated hydrocarbons (e.g. ethanol, methanol...), as the measuring sensitivity of the other electrochemical sensors present will be damaged.**

CONTACT INFORMATION

GasTech Australia Pty Ltd
24 Baretta Rd
Wangara Western Australia 6065
Tel 1800 999 902
Fax 1800 999 903
<http://www.gastech.com.au>