

# **SharpEye™**

## **Single IR Flame Detector**

Model 20/20R

# **User and Maintenance Manual**

TM 20/20R, Rev. A January 2005



### **ATEX Approved**

Ex II 2G  
EExd IIB + H<sub>2</sub> T5  
EExde IIB + H<sub>2</sub> T5

GasTech Australia Pty Ltd  
24 Baretta Rd  
Wangara Western Australia 6065  
Tel 1800 999 902  
Fax 1800 999 903  
<http://www.gastech.com.au>

**GASTECH**  
AUSTRALIA



The SharpEye Optical Flame Detector described in this document is the property of Spectrex, Inc.

No part of the hardware, software or documentation may be reproduced, transmitted, transcribed, stored in a retrieval system, or translated into any language or computer language, in any form or by any means, without prior written permission of Spectrex, Inc.

While great efforts have been made to assure the accuracy and clarity of this document, Spectrex, Inc. assumes no liability resulting from any omissions in this document, or from misuse of the information obtained herein. The information in this document has been carefully checked and is believed to be entirely reliable with all of the necessary information included. Spectrex Inc. reserves the right to make changes to any products described herein to improve reliability, function, or design, and reserves the right to revise this document and make changes from time to time in content hereof with no obligation to notify any persons of revisions or changes. Spectrex, Inc. does not assume any liability arising out of the application or any use of any product or circuit described herein; neither does it convey license under its patent rights or the rights of others.

**Warning:**

This manual should be carefully read by all individuals who have or will have responsibility for using, maintaining or servicing the product.

The Detector is not field-repairable due to the meticulous alignment and calibration of the sensors and the respective circuits. Do not attempt to modify or repair the internal circuits or change their settings, as this will impair the system's performance and void the Spectrex, Inc. Product warranty.



## TABLE OF CONTENTS

<b>1. Scope .....</b>	<b>1</b>
1.1 PRODUCT OVERVIEW.....	1
1.2 DOCUMENT OVERVIEW .....	1
<b>2. Technical Description .....</b>	<b>2</b>
2.1 PRINCIPLE S OF OPERATION .....	2
<b>3. Performance .....</b>	<b>4</b>
3.1 DETECTION SENSITIVITY .....	4
3.2 CONE OF VISION .....	6
3.3 FALSE ALARMS PREVENTION.....	7
<b>4. Operation .....</b>	<b>8</b>
4.1 VISUAL INDICATIONS.....	8
4.2 OUTPUT SIGNALS .....	9
4.2.1 <i>Optional latching</i> .....	10
4.2.2 <i>Built-In-Test (BIT)</i> .....	10
4.2.3 <i>Accessory Relay as EOL</i> .....	10
4.3 MODE SELECTION .....	10
4.3.1 <i>Function switch (SW1):</i> .....	11
4.3.2 <i>Address switch (SW2) (Optional):</i> .....	12
4.3.3 <i>Alarm Delay switch (SW3):</i> .....	13
4.4 BUILT IN TEST .....	14
<b>5. Technical Specifications .....</b>	<b>17</b>
5.1 ELECTRICAL SPECIFICATIONS .....	17
5.2 MECHANICAL SPECIFICATIONS.....	20
5.3 ENVIRONMENTAL SPECIFICATIONS .....	21
<b>6. Installation Instructions.....</b>	<b>22</b>
6.1 SCOPE .....	22
6.2 GENERAL CONSIDERATIONS .....	22
6.3 PREPARATIONS FOR INSTALLATION .....	23
6.4 CONDUIT INSTALLATION .....	23
6.5 DETECTOR MOUNTING .....	24
6.5.1 <i>Swivel Mount Kit:</i> .....	24
6.5.2 <i>Swivel installation (Figs. No. 8 and 9):</i> .....	24
6.6 WIRING (REFER TO FIG. 12).....	27
6.7 TERMINAL WIRING (SEE FIG. NO.10 AND NO.11.).....	28
6.8 MODE SELECTION .....	32
<b>7. Operating Instructions.....</b>	<b>33</b>
7.1 SCOPE .....	33
7.2 POWER-UP.....	33
7.3 RESET.....	33
7.4 FUNCTIONAL TESTING .....	33
7.4.1 <i>Manual BIT Test</i> .....	34
7.4.2 <i>Testing with fire simulator</i> .....	34
7.5 SAFETY PRECAUTIONS.....	35
<b>8. Maintenance Instructions .....</b>	<b>36</b>

8.1 SCOPE .....	36
8.2 MAINTENANCE INSTRUMENTATION AND PERSONNEL.....	36
8.3 PREVENTIVE MAINTENANCE PROCEDURES.....	36
8.4 PERIODIC MAINTENANCE PROCEDURES.....	36
8.4.1 Power-Up Procedure .....	36
8.4.2 Functional Test Procedure.....	36
8.5 MAINTENANCE RECORDS.....	37
8.6 TROUBLESHOOTING.....	37
8.6.1 Fault Indication .....	37
8.6.2 False Alarm or Warning Indication .....	37
<b>Appendix A - Wire Selection Tables.....</b>	<b>39</b>
<b>Appendix B – Typical Wiring Configurations .....</b>	<b>41</b>
<b>Appendix C – RS-485 Communication Network.....</b>	<b>45</b>
<b>Appendix D - Mounting the “EExde approved” version .....</b>	<b>47</b>
<b>Appendix E - IR Fire Simulator .....</b>	<b>51</b>

**LIST OF FIGURES**

Figure 1: IR Flame Detector .....	2
Figure 2: Flame Detector Assembly - Outline Drawing .....	3
Figure 3: Horizontal and Vertical Fields of View.....	6
Figure 4: Indication LEDs.....	8
Figure 5: Switch Locations .....	14
Figure 6: Electrical Interface .....	18
Figure 7: Flame Detector Assembly - Schematic Section .....	19
Figure 8: IR Detector and Swivel Mount Assembly.....	25
Figure 9: Swivel Mount Assembly - Outline Drawing.....	26
Figure 10: Terminal Board.....	29
Figure 11: Flame Detector Assembly - Wiring Diagram .....	30
Figure 12: IR Flame Detector with cover removed.....	31
Figure 13: Flame Detector Wiring Diagram.....	41
Figure 14: Typical wiring diagram for 4 wire controllers .....	42
Figure 15: Typical wiring diagram for controllers with alarm & fault loops.....	43
Figure 16: 4-20mA wiring .....	44
Figure 17: RS-485 networking.....	45
Figure 18: Flame Detector Assembly - Wiring Diagram .....	49
Figure 19: OPTION A Flame Detector Assembly - Wiring Diagram (“de version”).....	50
Figure 20: OPTION B Flame Detector Assembly - Wiring Diagram (“de version”).....	50
Figure 21: Fire Simulator.....	51
Figure 22: IR Detector Target Point .....	52

**LIST OF TABLES**

Table 1: Alarm Response Time Versus Range .....	4
Table 2: Response Sensitivity Ranges .....	5
Table 3: Immunity To False Alarm Sources .....	7
Table 4: Output Signals Versus Detector State .....	9
Table 5: Function Switch SW1 .....	11
Table 6: Sensitivity range .....	11
Table 7: Address Switches SW2 .....	12
Table 8: SW2 Address Setting .....	12
Table 9: SW3 Alarm Delay Setting .....	13
Table 10: Contact Ratings .....	19
Table 11: Mounting according to US Version .....	24
Table 12: Mounting according to EU Version .....	24
Table 13: Maximum DC resistance at 68 °F for copper wire.....	39
Table 14. Wiring length in feet (meter).....	39



# 1. Scope

## 1.1 Product Overview

The Spectrex Model 20/20R Single IR Flame Detector provides early warning of flaming fires involving organic (hydrocarbon fuels and vapours) materials. These fires emit strong IR radiation in the 4.4-micron spectral band where the CO<sub>2</sub> (main combustion product of any organic substance) has a unique spectral peak. This detector contains a “state-of-the-art” infrared sensor and optical filter that provides maximum sensitivity to the CO<sub>2</sub> emission spectral band at 4.4 micron. The detector withstands “harsh” environmental conditions, including extreme temperature, high humidity, vibrations, etc.

## 1.2 Document Overview

This manual describes the detector and its features and provides instructions on the installation, operation and maintenance.

This manual is divided into separate chapters as follows:

- Chapter 1. **Scope** - a general introduction and overview of the product and the Manual, with a brief description of its content.
- Chapter 2. **Technical Description** - the detector’s theory of operation.
- Chapter 3. **Performance** - the detector features and capabilities.
- Chapter 4. **Operation** - the detector’s operation modes, user interface and indications.
- Chapter 5. **Technical Specifications** - the Detector’s electrical, mechanical and environmental specifications.
- Chapter 6. **Installation Instructions**, including wiring and mode setting.
- Chapter 7. **Operating Instructions** and power-up procedures.
- Chapter 8. **Maintenance Instructions** and support procedures.
- Appendix A. **Wiring Selection Tables** for electrical wire selection according to installation configuration.
- Appendix B. **Typical Wiring Configurations** - wiring diagrams for installation.
- Appendix C. **RS-485 Communication Network**
- Appendix D. **Mounting the “EExde approved” version**
- Appendix E. **Long Range IR Fire Simulator**

## 2. Technical Description

- **Detection Range:** up to 50ft (15m) for a 1ft x 1ft (0.3m x 0.3m) fire.
- **Field Programmable Sensitivity:** two ranges.
- **Two Response Levels:** Warning & Detection.
- **Microprocessor Based:** Digital signal processing.
- **Built In Test:** Manual and Automatic (see section. 4.2.2).
- **Electrical Interface:**
  - Dry contact RELAYS.
  - Communication network RS-485.
  - 4-20mA output.
- **Certification:** Approved by ATEX.

### 2.1 Principles Of Operation

The Single IR flame detector provides early warning of flaming fires involving organic (hydrocarbon fuels and vapours) materials. These fires emit strong IR radiation in the 4.4-micron spectral band where the CO<sub>2</sub> (main combustion product of any organic substance) has a unique spectral peak.

This detector contains a “state-of-the-art” infrared sensor and optical filter that provides maximum sensitivity of the CO<sub>2</sub> emission spectral band at 4.4 micron.

The detector is designed to withstand “harsh” environment conditions, including extreme temperature, high humidity, vibrations, etc.

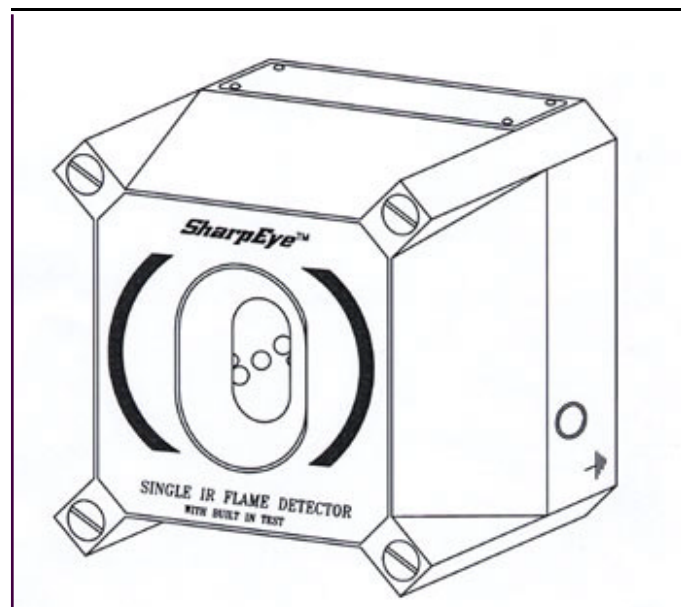

*Figure 1: IR Flame Detector*

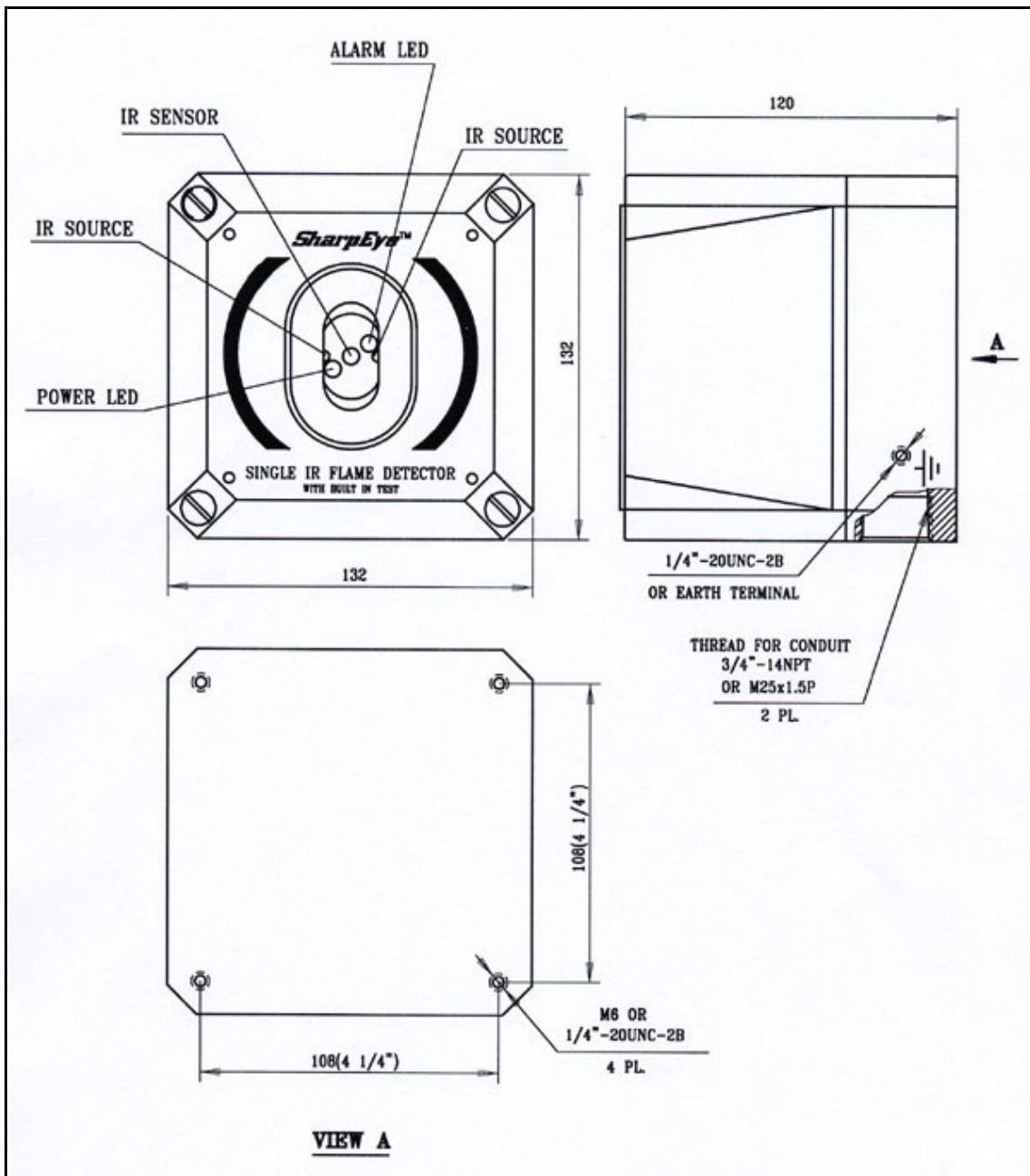

Figure 2: Flame Detector Assembly - Outline Drawing

## 3. Performance

### 3.1 Detection Sensitivity

Detection sensitivity is the maximum distance at which the detector will reliably detect a specific size of fire & typical type of fuel (standard fire).

#### Standard Fire:

A 1ft x 1ft (0.3m x 0.3m) Gasoline pan fire with max. wind speed of 6.5 ft/sec (2 m/sec).

#### Sensitivity Ranges:

The detector has two user selectable sensitivity ranges. For each range there are two response levels.

1. WARNING (Pre-alarm)
2. ALARM

The detection distance, for the WARNING level, is approximately 10% higher than the ALARM distance. Alarm response times for a “standard fire” at a specified range are shown hereunder.

**Table 1: Alarm Response Time Versus Range**

Sensitivity	1	2
Range – ft (m)	15 (5)	50 (15)
Response Time (sec)	5	10

For some typical ambient conditions the Zeta parameter as defined in NFPA 72 for the detector is 0.005 (1/meter).

**Note:**

Zeta parameters may vary significantly with changes in temp, air pressure, humidity, visibility conditions, etc.

**Other fuels**

The detector will react to other types of fires as follows:

Pan Fire Size: 1ft x 1ft (0.3m x 0.3m)

Maximum Wind Speed: 6.5 ft/sec (2 m/sec)

Maximum Response Time: 10 sec

**Table 2: Response Sensitivity Ranges**

Type Of Fuel	% Of Max. Distance at Each Sensitivity Range
Gasoline	100%
N-Heptane	100%
Alcohol 95%	75%
JP4	75%
Kerosene	75%
Diesel Fuel	50%

### 3.2 Cone Of Vision

Horizontal: 90°

Vertical: 90°

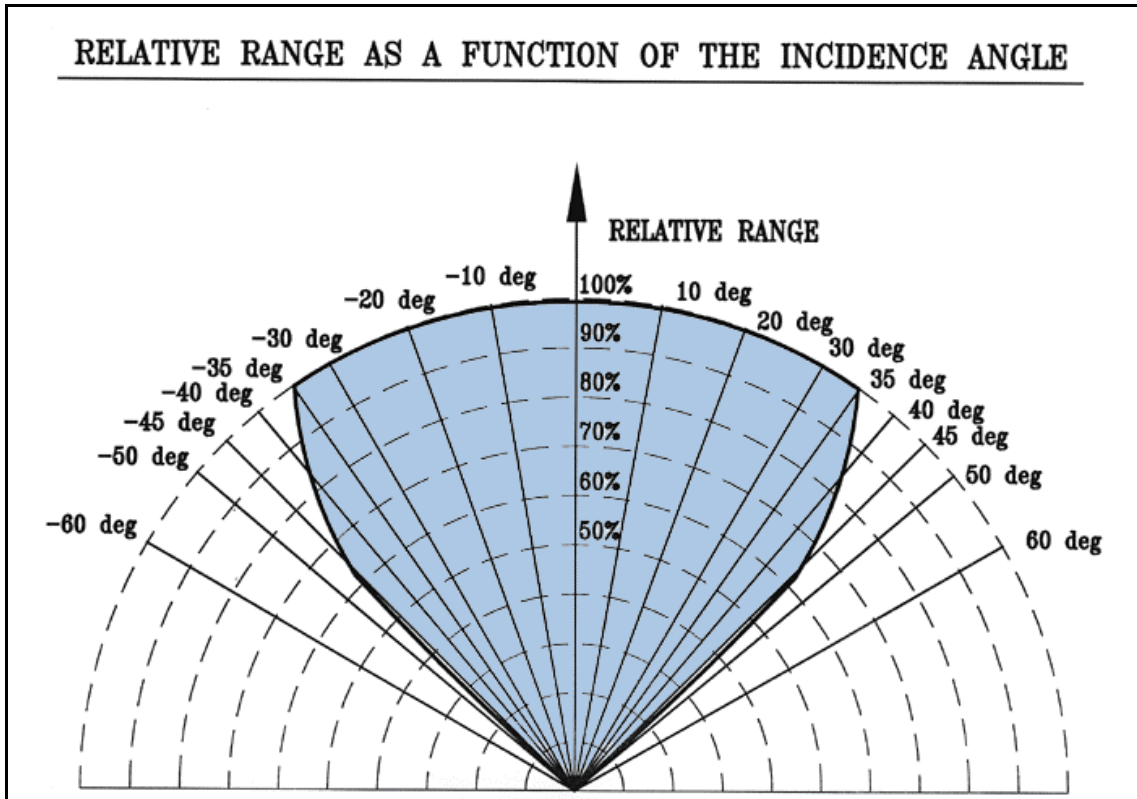

Figure 3: Horizontal and Vertical Fields of View

### 3.3 False Alarms Prevention

The detector will not provide an alarm or a warning signal as a reaction to the radiation sources specified below.

**Notes:**

IAD = Immune at Any Distance.

All sources are chopped from 0 to 20Hz.

**Table 3: Immunity To False Alarm Sources**

Radiation Source	Immunity Distance	
	ft	(m)
Incandescent frosted glass light, 100 W	1.7	0.5
Fluorescent light with white enamel reflector, standard office or shop, 40 W (or two 20 W)	IAD	
Arc welding [4 mm (5/32 in) rod; 240 A]	11.5	3.5
Halogen light 750W	16.5	5.5
Grinding metal	1.7	0.5
Lit cigar	3.3	1
Lit cigarette	1.7	0.5
Match, wood, stick including flare up	1.7	0.5

## 4. Operation

### 4.1 Visual Indications

Two LED-indications are located in the detector front window:

- i. Power LED (Yellow)
  - Normal - LED ON
  - BIT failure - LED flashes (4 Hz)
- ii. Alarm LED (Red)
  - Normal - LED OFF
  - Warning - LED flashes (2 Hz)
  - ALARM - LED ON

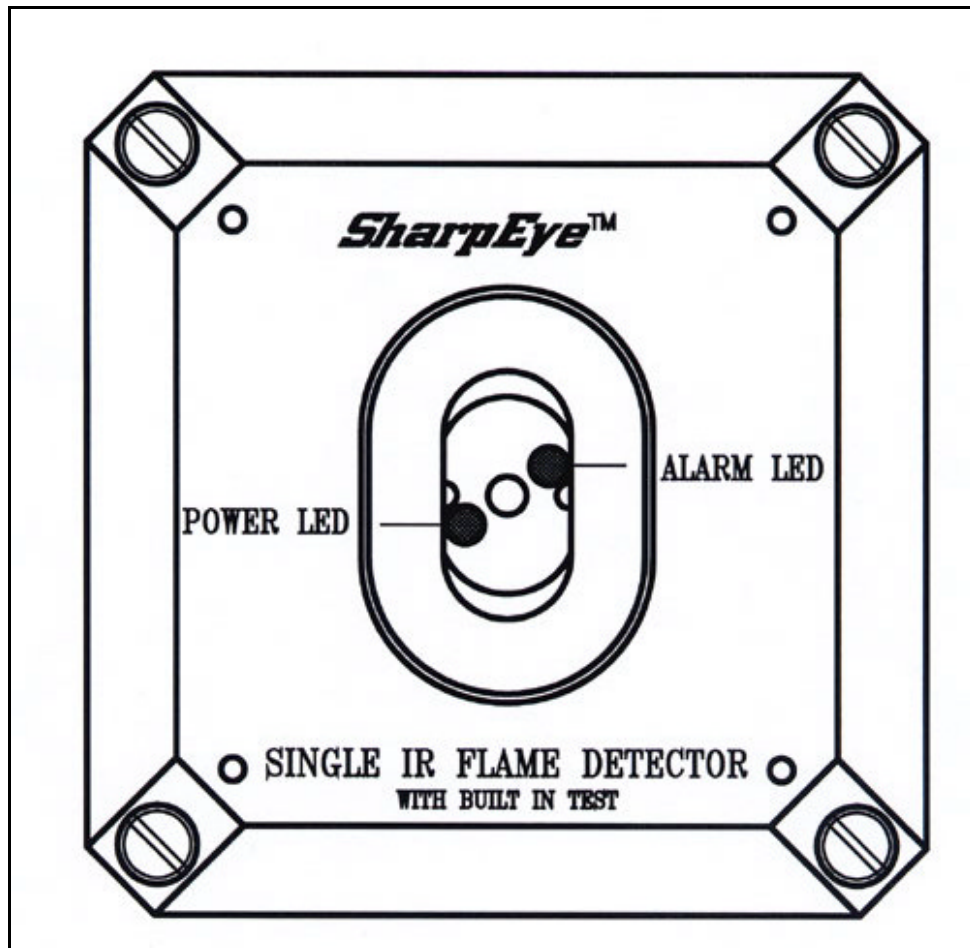

Figure 4: Indication LEDs

## 4.2 Output Signals

The detector controls the following outputs:

- Alarm relay
- Accessory relay
- Fault relay
- 4-20mA current output
- RS-485 communication

The detector can be in one of the following states.

<b>Normal:</b>	The detector is functioning normally.
<b>BIT:</b>	The detector performs a Built-In-Test.
<b>Warning:</b>	Fire detected - changed to warning – pre-alarm state.
<b>Alarm:</b>	Fire detected - changed to fire alarm state.
<b>Latched Alarm (Optional)</b>	The alarm outputs are latched due to the detection of a fire that has already been extinguished.
<b>Fault:</b>	A fault is detected during a BIT sequence or the power supply is too low. In each state the detector will activate different outputs as specified in table 5.

**Table 4: Output Signals Versus Detector State**

Detector State	SW1	Power Led	Alarm Led	Alarm Relay	Accessory Relay	Fault Relay	4-20mA Output
<b>Normal</b>		On	Off	Off	Off	On	5mA
<b>Warning</b>	Sw1-2 ON	On	Flash 2Hz	Off	On	On	10mA
<b>Alarm</b>		On	On	On	On	On	15mA
<b>Latch</b>	Sw1-1 ON	On	Off	On	Off	On	5mA
<b>Fault</b>		Flash 4Hz	Off	Off	Off	Off	0mA

- The detector will be in its FAULT state until it has passed a successful BIT.
- When SW1-2 is OFF, WARNING state is the same as the ALARM state.
- The alarm outputs will be activated as long as the alarm conditions are present and will stop approximately 5 seconds after the fire is no longer detected.

#### 4.2.1 Optional latching

The detector includes a latched alarm output capability, which operates according to the DIPswitch SW1-1 position. Upon the detection of a fire, the detection signal is latched until manually reset (disconnecting the power supply or performing a manual BIT).

#### 4.2.2 Built-In-Test (BIT)

Successful **Manual BIT** will activate the following outputs according to SW1 switches.

SW 1-4 ON	The ALARM relay will be activated for 3 seconds. The 4-20mA output will provide 15mA for 3 sec.
SW 1-5 ON & SW 1-4 ON	The ACCESSORY & ALARM relays will be activated for 3 sec. The 4-20mA output will provide 15mA for 3 sec.
SW 1-5 ON & SW 1-4 OFF	The ACCESSORY relay will be activated for 3 sec. The 4-20mA output will provide 10mA for 3 sec.

#### 4.2.3 Accessory Relay as EOL

When SW1-8 is ON then the accessory relay is used as End of Line relay. In this case, the accessory relay is active as long as the detector is not in its FAULT state.

**Note:** The detectors' status is available through its RS-485 communication link.

#### 4.3 Mode Selection

The detector has 3 DIPswitches, which enable the user to adapt the detectors' operation to specific applications:

- Function switch (SW1)
- Address switch (SW2) – only if using the RS-485 Serial address
- Alarm delay switch (SW3)

### 4.3.1 Function switch (SW1):

The user can select the desired mode of operation by means of this switch according to table 5:

**Table 5: Function Switch SW1**

SW.	ON Position	OFF Position
1	Alarm latching - enabled	Alarm latching – disabled <b>(default)</b>
2	Accessory relay activated at warning level	Accessory relay activated at detection level (together with Alarm relay) - <b>(default)</b>
3	Automatic & manual BIT <b>(default)</b>	Manual BIT only
4	Successful manual BIT activates the Alarm relay and the 4-20mA output turns to 15mA for approximately 3 seconds <b>(default)</b>	Successful manual BIT does not activate the Alarm relay.
5	Successful manual BIT activates the accessory relay and the 4-20mA output turns to 10mA for approximately 3 seconds <b>(default)</b>	Successful manual BIT does not activate the Accessory relay.
6*	Sensitivity range – see table 6 below <b>(default)</b>	Sensitivity range - see table 6
7*	Sensitivity range - see table 6 below	Sensitivity range - see table 6 <b>(default)</b>
8	Accessory relay used as End Of Line.	Accessory relay operates in accordance with the settings of SW1 <b>(default)</b>

\* See Table 6 for sensitivity range setting.

**Table 6: Sensitivity range**

Sensitivity	Range	SW1-7	SW1-6
1 (lowest)	16.5 ft (5m)	OFF	OFF
2 (highest)	50 ft (15m)	OFF	ON

### 4.3.2 Address switch (SW2) (Optional):

The address switch provides 64 alternative addresses that can be used with the RS-485 communication link. See tables 7 and 8.

**Table 7: Address Switches SW2**

SWITCH	Description
1	Address bit 0 (LSB)
2	Address bit 1
3	Address bit 2
4	Address bit 3
5	Address bit 4
6	Address bit 5 (MSB)

**Legend:**

0 = OFF

1 = ON

LSB = Least Significant Bit

MSB = Most Significant Bit.

SWITCH SW2-7 and SWITCH SW2-8 are unused.

**Table 8: SW2 Address Setting**

Address	SW2-6	SW2-5	SW2-4	SW2-3	SW2-2	SW2-1
0	OFF	OFF	OFF	OFF	OFF	OFF
1	OFF	OFF	OFF	OFF	OFF	ON
2	OFF	OFF	OFF	OFF	ON	OFF
3	OFF	OFF	OFF	OFF	ON	ON
4	OFF	OFF	OFF	ON	OFF	OFF
5	OFF	OFF	OFF	ON	OFF	ON
.		.				
.		.				
.		.				
62	ON	ON	ON	ON	ON	OFF
63	ON	ON	ON	ON	ON	ON

**Note:** Default address = 0

### 4.3.3 Alarm Delay switch (SW3):

The detector is equipped with an Alarm Delay option, which provides programmable time delays of 0 to 30 seconds with eight (8) fixed settings at: 0, anti-flare, 3, 5, 10, 15, 20, and 30 seconds, using SW3 switches 1-3. See table 10.

When an Alarm (Detection) level condition is encountered, the detector delays the execution of the Alarm output relay by the specified period of time. The detector will then evaluate the condition for 3 seconds. If the Alarm level is still present, the Alarm output will be activated. If this condition no longer exists, the detector will return to its standby state. The Alarm delay option will affect the output relay and the 4-20mA output but not the alarm LED.

**Table 9: SW3 Alarm Delay Setting**

Delay (seconds)	SW3 switches			
	4	3	2	1
0	---	OFF	OFF	OFF
Anti Flare (default)	---	OFF	OFF	ON
3	---	OFF	ON	OFF
5	---	OFF	ON	ON
10	---	ON	OFF	OFF
15	---	ON	OFF	ON
20	---	ON	ON	OFF
30	---	ON	ON	ON

**Note:** The new FM approval from January 2003 does not allow using 20 and 30 second delay.

## **ANTI FLARE**

Anti Flare mode is selected to prevent false alarm in locations where fast flares may be present. The Time delay for fire alarm in this mode is from 2.5 to 15 seconds (mostly less than 10 seconds).

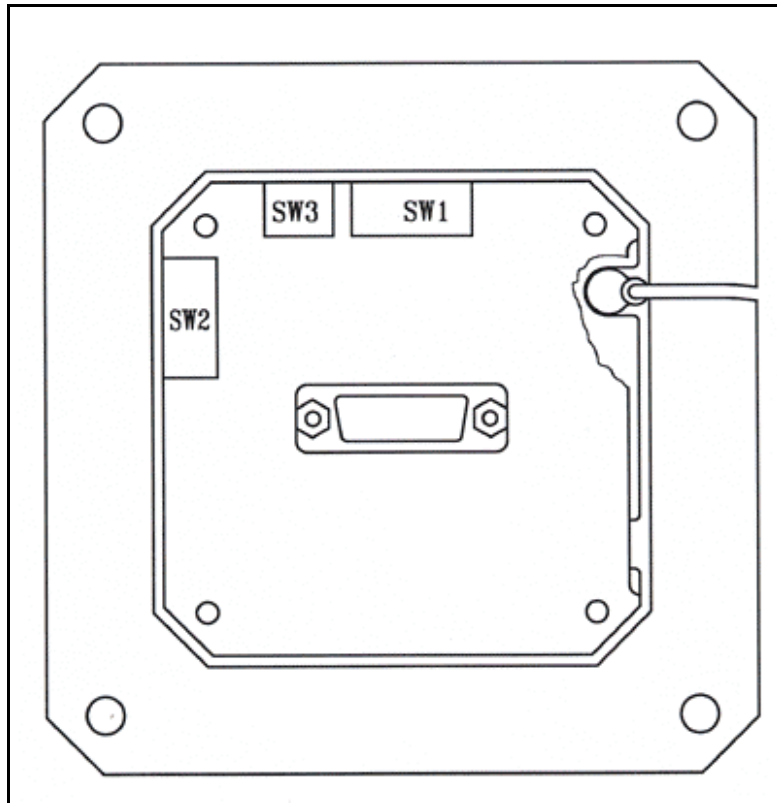

*Figure 5: Switch Locations*

### **4.4 Built In Test**

#### **A. General**

The detectors' Built In Test (BIT) checks the following:

- Electronics circuitry
- Sensors
- Window cleanness

The detector is set by default to perform the BIT automatically and manually (SW1-3 = ON) or can be manual only (set SW1-3 = OFF).

An Automatic BIT will regularly check the detector and warn of a problem by operating the Fault relay (and setting the mA output to 0mA). Also, the Power LED will Flash.

The manual BIT allows testing of unit at commissioning stage or as required and will act in a similar manner to Auto BIT except that alarm/accessory relay operation can also be tested (if appropriate SW1 switches selected)

## B. Principles

If the result of a BIT is the same as the detector's current status (NORMAL or FAULT), the detector's status will not change.

If the result of a BIT differs from the detector's current status, then a second BIT is executed after a delay of 0.5 seconds.

If the result of the second BIT is the same as the previous BIT (and still differs from the current status), the detectors' status will be changed. (From NORMAL to FAULT or from FAULT to NORMAL).

**Note:** When in FAULT status the detector disables its outputs.

## C. Manual BIT only (SW1-3 = OFF)

The BIT is initiated manually by momentarily connecting Terminal No. 3 with Terminal No. 2.

Successful manual BIT activates the following:

- FAULT relay is closed.(normal)
- ALARM relay is activated for 3 sec (SW1-4 = ON)
- ACCESSORY relay is activated for 3 sec (SW1-5 = ON)
- 4-20mA OUTPUT current will be 15mA when SW1-4 = ON  
or 10mA when SW1-5 = ON & SW1-4 = OFF.

Unsuccessful BIT activates the following:

- FAULT relay is released. (Operated)
- 4-20mA output indicates FAULT condition (0mA).
- POWER LED (yellow) flashes (4 Hz).

### **Important Note!**

If SW1 switches 4 or 5 are in their "ON" position, the ALARM and ACCESSORY relays will be activated during a MANUAL BIT, therefore, automatic extinguishing systems or any external devices, that should not be activated during BIT, should be disconnected.

## **D. Automatic & Manual BIT (SW1-3 = ON)**

### ***Manual Bit***

Functions as described in Para. 4.4.c. In the case of an unsuccessful BIT all outputs will function as described in para. 4.4.c, but the BIT will be automatically executed every 1-minute. This mode of operation will continue until two consecutive successful BIT's have been encountered. As a result, the detector will resume its normal operation.

### ***Automatic BIT***

The detector automatically performs a BIT every 15 minutes. A successful BIT sequence does not activate any indication:

- The FAULT relay is CLOSED (NORMAL).
- The POWER LED is ON (NORMAL).

An unsuccessful BIT sequence activates the following:

- The FAULT relay is opened.
- 4-20mA output indicates FAULT (0mA).
- The POWER LED (yellow) flashes (4 Hz).
- BIT procedure will be performed every 1 minute.

## 5. Technical Specifications

### 5.1 Electrical Specifications

- A. **Operating Voltage:** 18-32 VDC
  
- B. **Power Consumption:**
  - Max. 150mA in Stand-by
  - Max. 200mA in Alarm
  
- C. **Electric input protection:** The input circuit is protected against voltage-reversed polarity, voltage transients, surges and spikes according to MIL-STD-1275A.

D. Terminals:

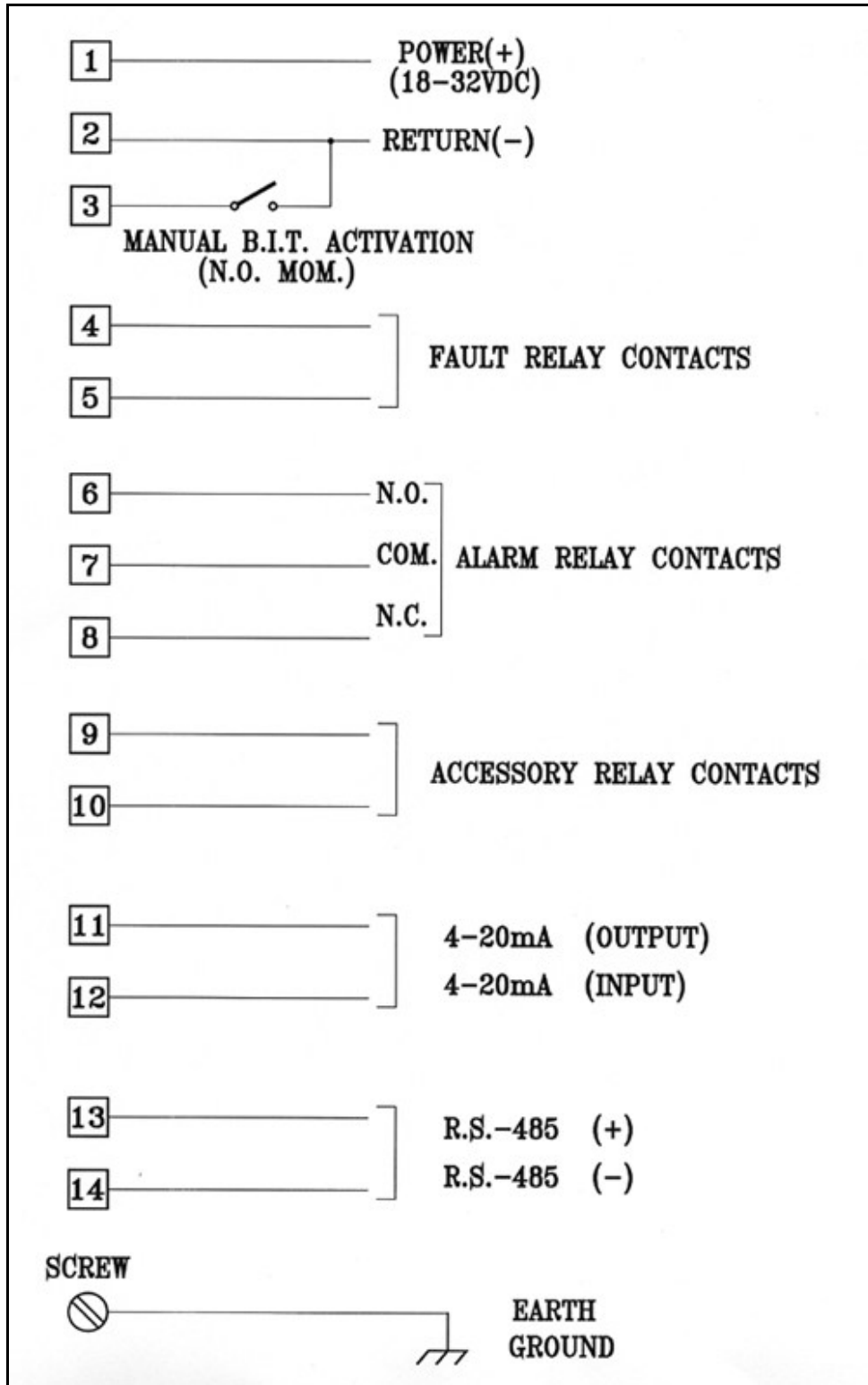

Figure 6: Electrical Interface

### E. Electrical outputs

- **Dry Contact Relays:**

Table 10: Contact Ratings

Relay Name	Type	Normal position	Maximum Ratings
Alarm	SPDT	N.O. N.C.	2A at 30VDC or 0.5A at 250 VAC
Accessory	SPST	N.O.	5A at 30VDC or 250 VAC
Fault	SPST	N.C.	5A at 30VDC or 250 VAC

- **4-20mA Current Output**

Terminals 11 and 12:

FAULT	< 2mA	(Typical 0)
NORMAL	4 - 6mA	(5)
WARNING	9 - 11mA	(10)
ALARM	14 -16mA	(15)

- **Communication Network:**

The detector is equipped with an RS-485 communication link that can be used in installations with computerized controllers.

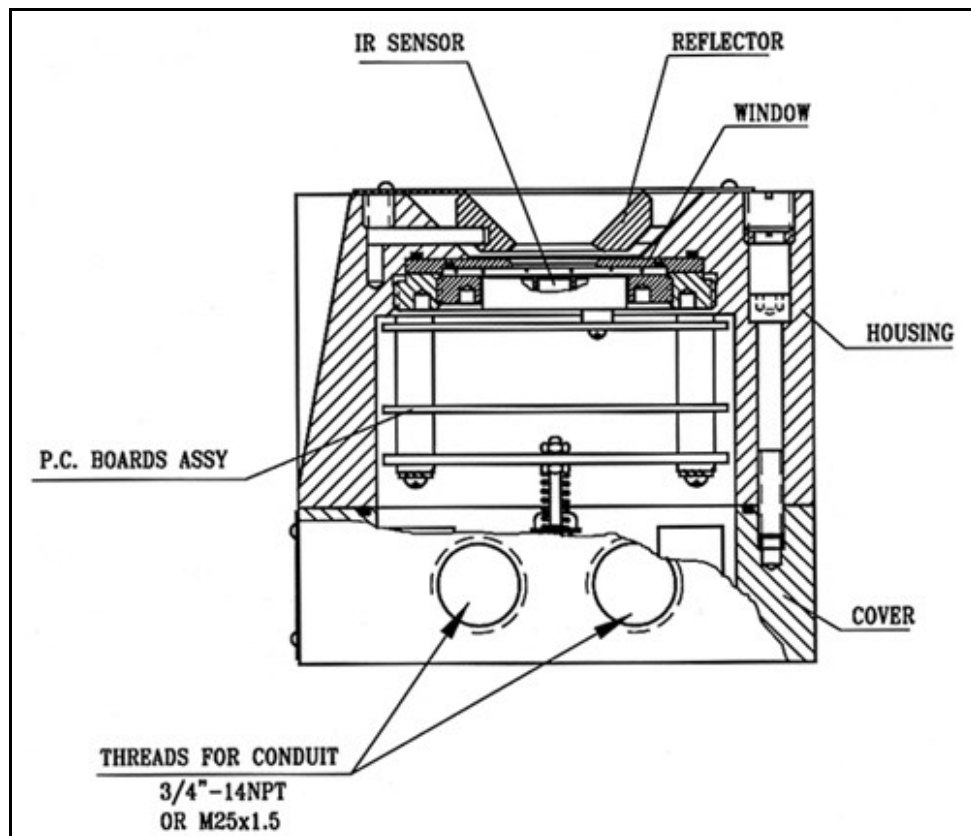

Figure 7: Flame Detector Assembly - Schematic Section

## 5.2 Mechanical Specifications

### A. Enclosure

Aluminum: Chromate coating and Epoxy enamel finish  
or  
Stainless Steel 316: Electrochemical passivated coating

### B. Explosion proof

ATEX	Ex II 2G SIRA 00ATEX 1163, 1164	
	EExd IIB + H <sub>2</sub> T5	Temp. -40°F (-40 °C) to 160°F (70 °C) Option: -40°F (-40 °C) to 185°F (85 °C) Per EN 50014 & EN 50018
	EExde IIB + H <sub>2</sub> T5	Temp. -40°F (-40 °C) to 160°F (70 °C) Per EN 50014, 50018 & 50019 (see Appendix D)
FM approval (Design to Meet)	Class I Div. 1 Groups B, C and D; Class II Div. 1 Groups E, F and G.	

### C. Water and dust tight

NEMA 250 type 6p.  
IP 66 and IP 67 per EN 60529

### D. Electronic Modules

Conformal coating.

### E. Electrical connection (two entries)

Standard 3/4"-14NPT conduit  
Optional M25 x 1.5 (ISO).

### F. Dimensions

Base: 5.2 x 5.2 in (132 cm x 132 cm)  
Height: 4.7 in (120 cm)

### G. Weight

8.1 lbs.	(3.7 Kg)	– Aluminum Alloy
14.3 lbs.	(6.5 Kg)	– ST.ST 316

### 5.3 Environmental Specifications

#### A. High Temperature

Design to meet MIL-STD-810C, method 501.1 procedure II

Operating temperature: +160 °F (+70 °C)

Optional operating temperature: +185 °F (+85 °C)

Storage temperature: +185 °F (+85 °C)

#### B. Low Temperature

Design to meet MIL-STD-810C, method 502.1, procedure I

Operating temperature: -40 °F (-40 °C)

Storage temperature: -65 °F (-55 °C)

#### C. Humidity

Design to meet MIL-STD-810C, method 507.1, procedure IV

Relative humidity of up to 95% for the operational temperature range.

#### D. Salt Fog

Design to meet MIL-STD-810C, method 509.1, procedure I

Exposure to a 5% Salt Solution Fog for 48 hours.

#### E. Dust

Design to meet MIL-STD-810C, method 510.1, procedure I

Exposure to a dust concentration of 0.3 frames/cubic ft. at a velocity of 1750 fpm, for 12 hours.

#### F. Vibration

Design to meet MIL-STD-810C, method 514.2, procedure VIII

Vibration at an acceleration of 1.1g within the frequency range of 5-30 Hz, and an acceleration of 3g within the frequency range of 30-500 Hz.

#### G. Mechanical Shock

Design to meet MIL-STD-810C, method 516.2, procedure I

Mechanical Shock of 30g half-sin wave, for 11 msec.

## 6. Installation Instructions

### 6.1 Scope

The "Spectrex" Model 20/20R is a self-contained Optical Flame Detector, designed to operate as a stand-alone unit directly connected to alarm systems or automatic fire extinguishing systems. The detector can form part of a more complex system where many detectors and other devices are integrated through a common control unit. This chapter does not attempt to cover all of the standard practices and codes of installation. Rather, it emphasizes specific points of consideration and provides some general rules for qualified personnel. Wherever applicable, special safety precautions are stressed.

### 6.2 General Considerations

#### Very Important

The detector should be aimed toward the center of the detection zone and have a completely unobstructed view of the protected area. Whenever possible, the detector face should be tilted down at a slight angle to prevent the accumulation of dust and dirt. Do not start an installation unless all conceivable considerations regarding detector location have been taken into account.

To ensure optimal performance and an efficient installation, the following guidelines should be considered:

#### A. Sensitivity

To determine the level of sensitivity (SW1), the following issues should be considered:

- Size of fire at determined distance to be detected.
- Type of flammable materials.

#### B. Spacing and Location

The number of detectors and their locations in the protected area are affected by:

- Size of the protected area
- Sensitivity of the detectors
- Obstructed lines of sight
- Cone of view of the detectors

#### C. Environment

- Dust, snow or rain can reduce the detectors sensitivity and require more maintenance activities.
- The presence of high intensity flickering of IR sources may affect sensitivity.

### **6.3 Preparations for Installation**

Installation should comply with NFPA 72E, as applicable to flame detectors, where required. The detectors can be installed with the use of general-purpose common tools and equipment.

- 1 Verify the appropriate Purchase Order. Record the Part No. and the Serial No. of the detectors and the installation date in the appropriate Log-book.
- 2 Open the container package prior to detector installation and visually inspect the detector.
- 3 Verify that all components required for the detector installation are readily available before commencing the installation. In case that the installation is not completed in a single session, secure and seal detectors and conduits.
- 4 For wiring, use color-coded conductors or suitable wire markings or labels. 12 to 20 AWG wires may be used for site wiring. The selection of wire gauge should be based on the number of detectors used on the same line and the distance from the control unit, in compliance with specifications (See Appendix A).

### **6.4 Conduit Installation**

- 1 To avoid water condensation water in the detector, it should be installed with the conduits placed downward, and should include drain holes.
- 2 When using the optional swivel mount, use flexible conduits for the last portion connecting to the detector.
- 3 For installations in atmospheres as defined in Group B of the NFPA 72E, conduits inlets should be sealed.
- 4 When pulling the cables through the conduits, ensure that they are not tangled or stressed. Extend the cables about 12 in. (30 cm.) beyond the detector location to accommodate wiring after installation.
- 5 After the conductor cables have been pulled through the conduits, perform a continuity test.

## 6.5 Detector Mounting

The detector may be mounted on a simple fabricated bracket, or preferably the optional Swivel Mount, Model 20/20-003. The Swivel Mount enables the detector to be rotated up to 40 degrees in all directions.

### 6.5.1 Swivel Mount Kit:

**Table 11: Mounting according to US Version**

Item	Qty.	Type/Model	Location
Swivel Mount	1	20/20-003	
1/4"-20UNC Screw	4	1/4" –20UNC	Detector - Holding plate
1/4" Spring Washer	4	1/4"	Detector - Holding plate

**Table 12: Mounting according to EU Version**

Item	Qty.	Type/Model	Location
Swivel Mount	1	20/20-003-1	
Screw	4	M6 X 1P	Detector - Holding plate
Spring Washer	4	M6	Detector - Holding plate

### 6.5.2 Swivel installation (Figs. No. 8 and 9):

- 1 Place the swivel mount (item 6) in its designated location and secure it with four (4) M6 or 1/4" screws (item 11) (recommended), placed 3.0 in. (76.2 mm.) apart on the swivel mount plate (item 10).

**Note:** Skip this step if the Swivel Mount is already installed. Also detector removal for maintenance purpose does not require Swivel Mount removal.

- 2 Unpack the detector.
- 3 Place the detector, with its electrical entries/conduit inlets pointing down, on the holding plate of the swivel mount (item 7). Secure the detector by four (4) 1/4"-20UNC (or M6) screws with 1/4" (or M6) spring washers from the Swivel Mount Kit (using the holes (item 5)). Use 3/16 Hex Key for 1/4" screws and No. 5 for M6 screws.
- 4 Tighten the three locking 3/8"-24UNF screws (item 8) of the swivel mount ring until the friction in the ball joint holds the detector in its position, maintaining the ability to be moved by hand-applied force (Use 3/16" HEX KEY).
- 5 Point the detector towards the protected area and make certain that the view of the area. Secure the detector in that position by tightening the locking screws (item 8) of the swivel mount ring.

The detector is now correctly located and aligned and ready for connecting to the system.

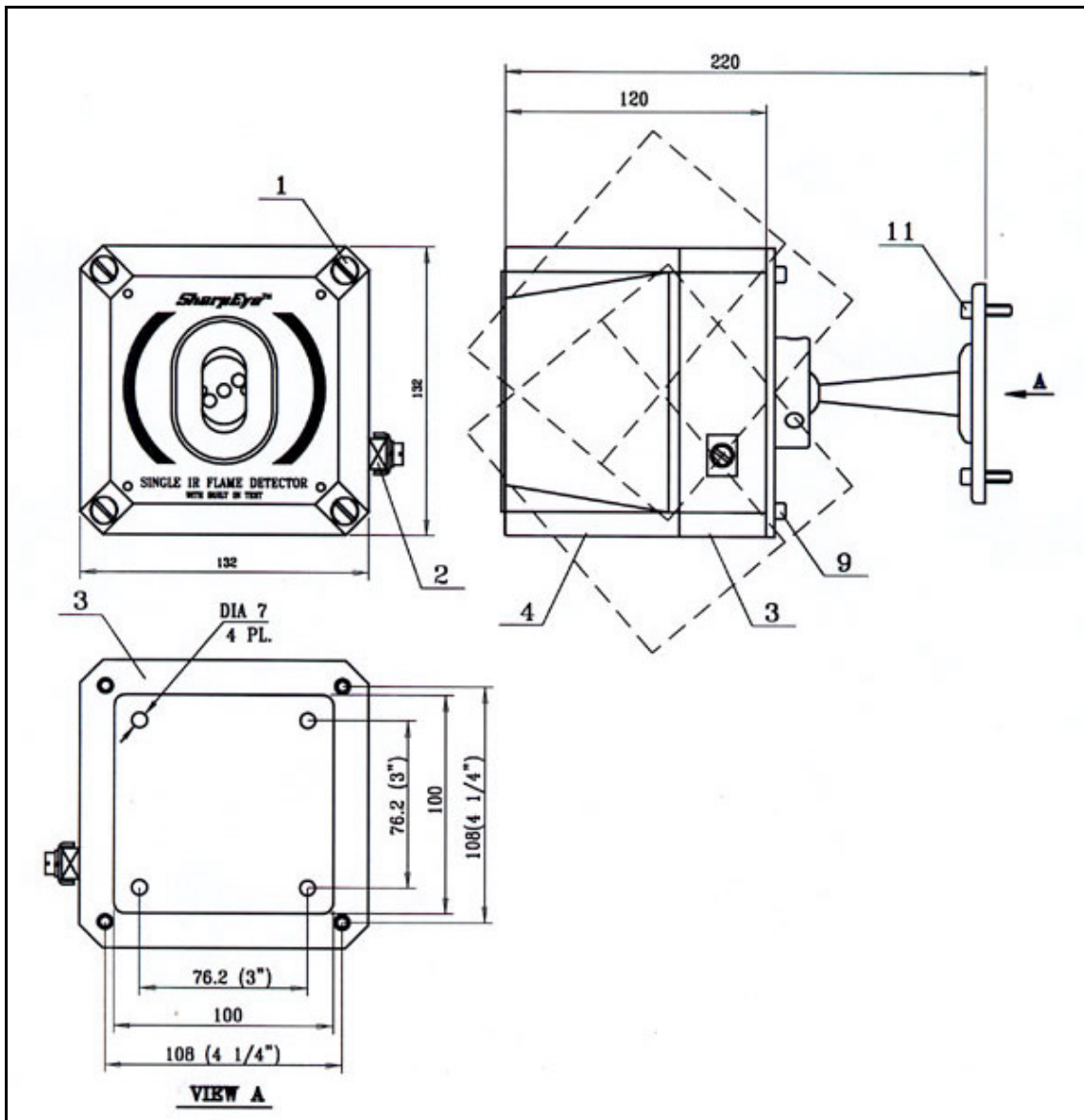
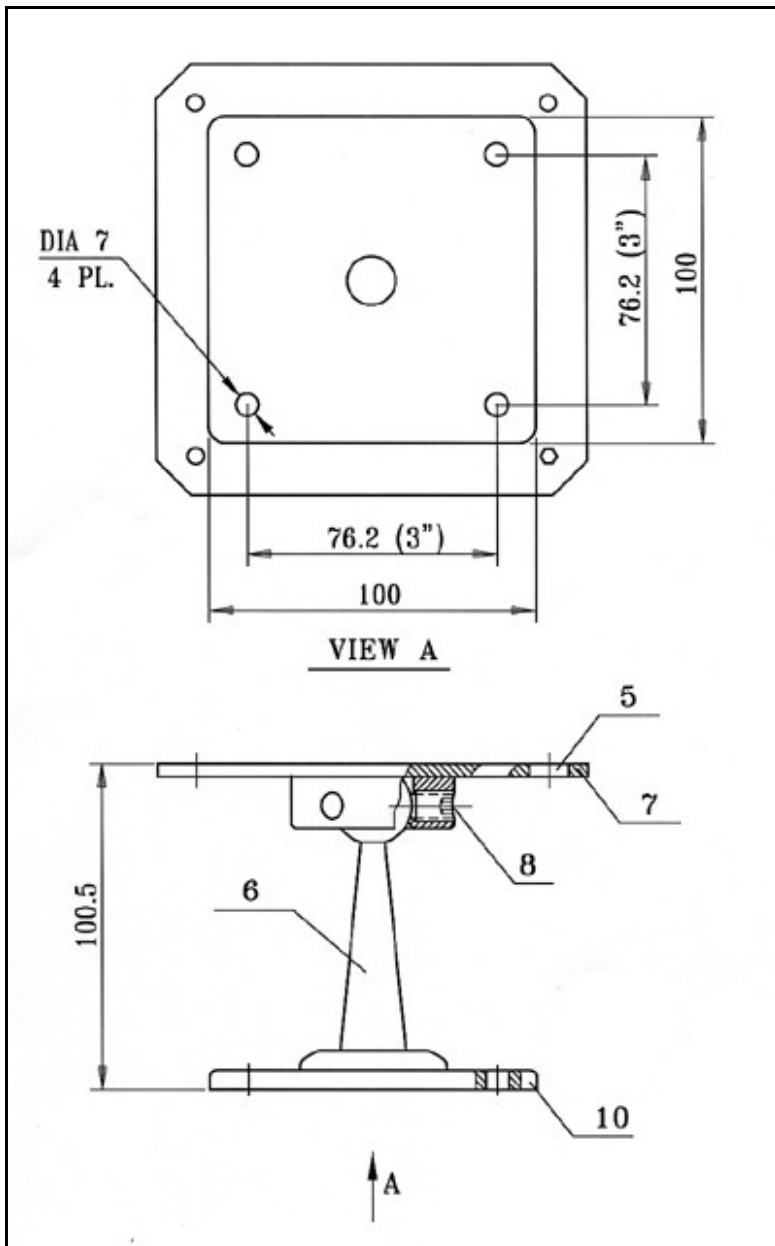

Figure 8: IR Detector and Swivel Mount Assembly



Description	
1	Protective Set Screws
2	Ground Terminal (for ATEX) or Ground Thread (for FM)
3	Back Cover
4	Housing
5	Swivel Mount Screw Hole
6	Swivel Mount
7	Holding Plate
8	Locking Screws
9	Detector Mounting Screws
10	Swivel Mount Plate
11	Swivel mounting screws

Figure 9: Swivel Mount Assembly - Outline Drawing

## 6.6 Wiring (Refer to Fig. 12)

- 1 Disconnect power.
- 2 Remove the four (4) protective set-screws from detector front. (Fig. 8 Item 1)
- 3 Release the four (4) socket-head screws that secure the detector housing (Item 1) to its back cover (Item 5) Using HEX KEY No. 5. Hold the housing (Item 1) during the removal of the screws. With the screws removed, pull the detector housing (Item 1) from its cover (Item 5). The cover remains attached to the detector mount, the housing slides under the cover and remains attached to it by a securing cable (Item 2). The Terminal Board inside the detector cover is now revealed.
- 4 Remove the protective plug mounted on the detector conduit inlet, pull the wires through the detector cover (Item 5) and secure them firmly to the cover using the cable-clamp (Item 3) attached to it. Use a 3/4"-14NPT or M25x1.5 explosion-proof conduit connection or cable gland to assemble the conduit / cable to the detector.
- 5 Connect the wires to the required terminals (Item 4) according to the wiring diagram. See paragraph 6.7 and figures no. 10 and no. 11.
- 6 Connect the grounding wire to the ground screw outside the detector cover (Fig. 8 item 2).

**The detector must be well grounded to *Earth Ground* for proper operation.**

- 7 Verify the wiring. Improper wiring may damage the detector.
- 8 Check the wires for secure mechanical connection and press them neatly against the terminal board to prevent them from interfering while closing the detectors' housing.

### 6.7 Terminal wiring (See Fig. No.10 and No.11.)

The detector contains a Terminal Board consisting of two (2) terminal blocks (Item 4). The left terminal block is labeled 1 to 7, the right terminal block is labeled 8 to 14.

**The following describes the function of each electrical terminal of the detector:**

- **Power Supply** (Terminal Numbers 1, 2):  
Input power - Terminal No. 1.  
The RETURN - Terminal No. 2.
- **Manual Bit Activation** (Terminal No. 3):  
Terminal No. 3 is used for the Manual BIT activation. The manual BIT is initiated by a momentary connection of Terminal No. 3 to the power supply Return line (terminal 2).
- **Fault Relay** (Terminal Numbers 4, 5):  
The Fault output is N.O. SPST relay at Terminals No. 4 and 5. The contacts are closed when the detector is in its normal operational condition.
- **Alarm Relay** (Terminal Numbers 6, 7, 8):  
The Alarm output is a change over contact relay (SPDT).  
Terminal No. 6 is the N.O. relay contact.  
Terminal No. 7 is the COMMON relay contact.  
Terminal No. 8 is the N.C. relay contact.
- **Accessory Relay** (Terminal Numbers 9, 10):  
The Accessory output is N.O. SPST relay at Terminals No. 9 and 10.  
The Accessory relay may act in parallel with the ALARM relay to activate another external device or it may provide a warning signal, depending on the position of SW1-2.

#### Note

To protect the dry contacts from voltage surges when connected to reactive loads (electric motors, sirens, etc.), connect an appropriate varistor over these contacts.

- **4-20mA Output** (Terminal Numbers 11, 12):  
Terminal Numbers 11 and 12 are used for analog, 4-20mA current output as specified in paragraph 4.e  
Terminal No. 11 - output Terminal.  
Terminal No. 12 - input Terminal (see appendix B for more details)
- **RS-485** (Terminal Numbers 13, 14):  
Terminal Numbers 13 and 14 are used for communication network as specified in appendix C.  
Terminal No. 13 - positive (+) lead.  
Terminal No. 14 - negative (-) lead.

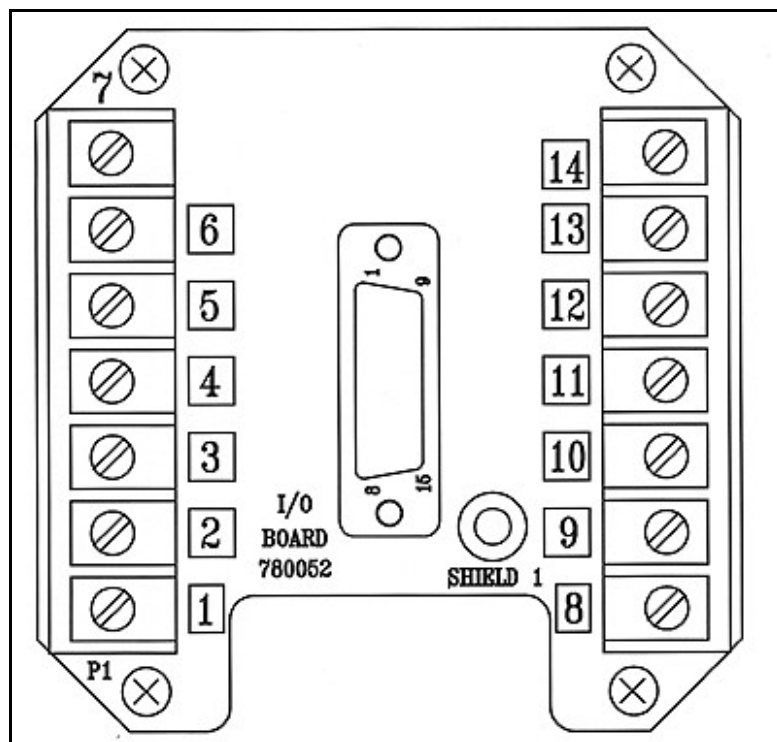

*Figure 10: Terminal Board*

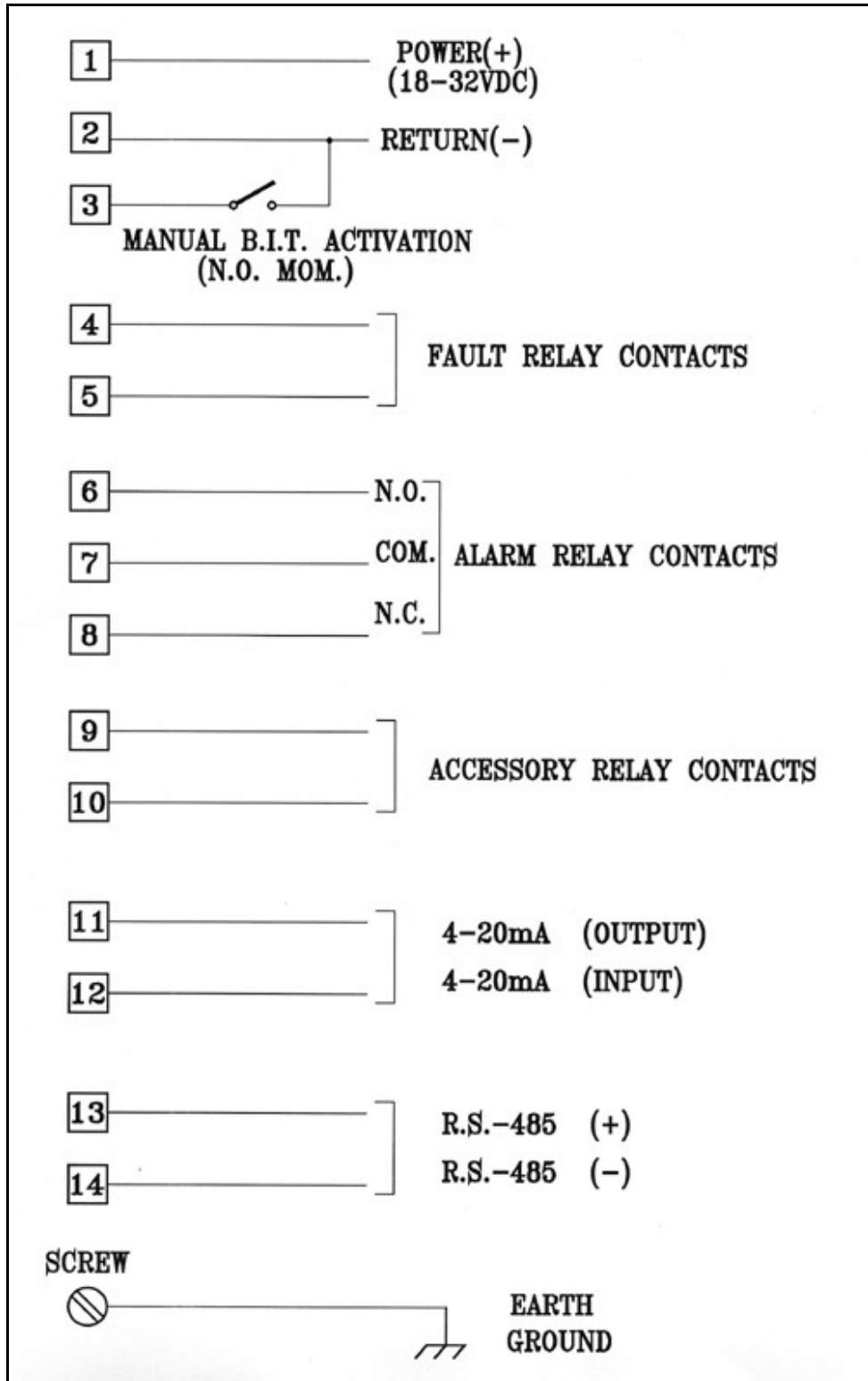
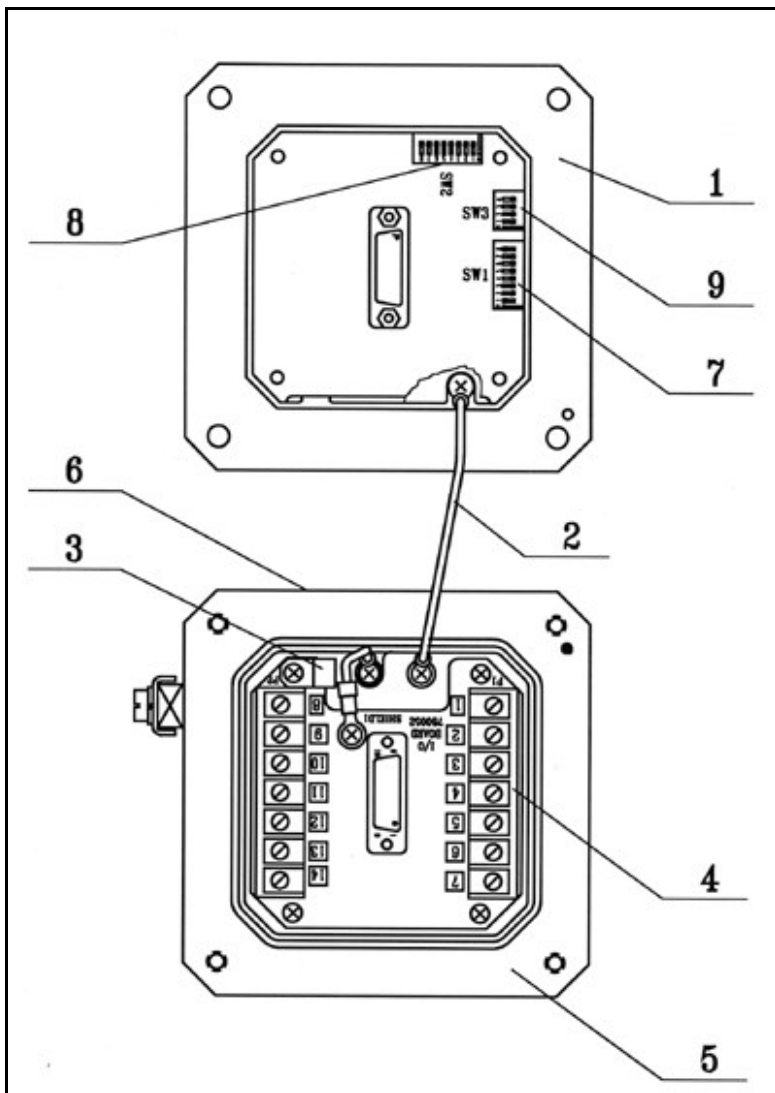

Figure 11: Flame Detector Assembly - Wiring Diagram



Description	
1	Housing
2	Securing Cable
3	Cable Clamp
4	Terminal Board
5	Back Cover
6	Inlet Conduit
7	DIP Switch1
8	DIP Switch2
9	DIP Switch3

Figure 12: IR Flame Detector with cover removed

## 6.8 Mode Selection

When wiring is completed the operational mode can be selected.

Mode selection is achieved by means of 3 DIPswitches listed below:

SW1 - Function switch – Fig. 12 Item 7 (see table 6)

SW2 - Address switch – Fig. 12 Item 8 (see table 9)

SW3 - Alarm Delay switch – Fig. 12 Item 9 (see table 10)

### **Function Switch (SW1):**

Modes of operation are selected by DIPswitch (SW1) (Item 7) according to the selection table in paragraph 4.3.1.

### **Address Switch (SW2):**

The detector has the capability of acting as an addressable device.

The address switch (Item 8) provides 64 addresses, which can be used by the RS-485 communications link as described in paragraph 4.3.2.

### **Alarm Delay Switch (SW3):**

An Alarm Delay may be required for certain applications. The detector has an Alarm Delay switch (SW3) (Item 9), permitting time delays from 0 to 3, 5, 10, 15, 20 and 30 seconds respectively (See table 10).

- 1 *Function Switch (SW1)*: Set all eight (8) switches of SW1 to their appropriate settings (ON/OFF), to achieve the required functional mode (See paragraph 4.3.1).
- 2 *Address Switch (SW2)*: Choose the address number from 0 to 63 for the detector and set switches 1 -6 according to the selection table at paragraph 4.3.2  
**Note:** When a multi detector installation is used with RS-485 communication, then each detector must have an individual address.
- 3 *Alarm Signal Delay Switch (SW3)*: Set SW3 to the appropriate position to achieve the required time delay. See paragraph 4.3.3.
- 4 Verify that the “O” Ring is in its groove in appropriate position on the back cover.
  - Close the detector
  - Connect the housing to the cover using the alignment pin on the back cover.
  - Tighten the four (4) socket-head screws to secure the detector housing to its back cover (tightening torque 1 Kg \* M).
- 5 Install the four (4) set-screws that protect the socket-head screws.

The Detector is now wired, assembled and its operational mode properly set.

## 7. Operating Instructions

### 7.1 Scope

The following instructions are designed to obtain optimal performance from the detector over its life cycle.

### 7.2 Power-Up

- 1 Apply power and wait approximately 60 seconds for the automatic self-test of the detector.

**Note:** Applying power initiates the following sequence:

- POWER LED flashes
  - BIT is executed, if successful then:
    - POWER LED turns ON continuous
    - FAULT relay contacts close
- 2 Wiring Inspection: If a short-circuit or line discontinuity exists, indications will appear on the control unit display panel. Review your wiring.
  - 3 The detector goes into its FAULT state when supply voltage drops under 16.5V. The detector status goes back to NORMAL, when the supply voltage is above 17.5V.
  - 4 Detector Inspection: Visually inspects the viewing window of the detector. It should be clean and clear. The POWER LED should be ON and the ALARM LED should be OFF. The ALARM and ACCESSORY relays should be OFF and the FAULT relay should be ON. The 4-20mA Output should be 5mA.
  - 5 If any of the outputs or indications is different from the description in step 4, see paragraph 8.6.1 for troubleshooting.

The Flame Detector is now ready for Functional Testing.

### 7.3 Reset

If optional latching alarm has been selected, RESET of a detector when in its ALARM state, is achieved by disconnecting power (terminal No. 1 or terminal No. 2), or initiation of a manual BIT.

### 7.4 Functional testing

Following is a test procedure for proper functioning of the detector. The detector can be tested using the Manual Built-in-Test or the Spectrex IR Fire Simulator - 20/20-312

### 7.4.1 Manual BIT Test

**Important Note!**

If SW1 switches 4 and 5 are in their "ON" position the Alarm, Accessory Relays and 4-20mA Output will be activated during a manual BIT, therefore, automatic extinguishing systems or any external devices that may be activated during BIT must be disconnected.

- 1 Verify that the detector is operating properly.
- 2 Initiate manual BIT. After a few seconds the following occurs:
  - Alarm Relay will be activated and the 4-20mA output turns to 15mA for 3 seconds (only if SW1-4 is ON).
  - Accessory Relay will be activated and the 4-20mA output turns to 10mA for 3 seconds (only if SW1-5 is ON).
  - The 2 LEDs should be ON.
  - Fault Relay will stay active during the test.

### 7.4.2 Testing with fire simulator

This test is used to simulate an exposure of the detector to a real fire condition. The detector is exposed to the radiation in the specified detection level. As a result the detector must generate a Fire Alarm signal.

**Important Note!**

If the detector is exposed to a fire simulator, the Alarm and Accessory Relays and 4-20mA will be activated during the simulation. Therefore, automatic extinguishing systems or any external devices, which may be activated during this process, must be disconnected.

- 1 Apply power to the system and wait up to 60 seconds for turning of the detector to normal state. Power LED turns on. If the detector is on, skip this step.
- 2 Aim the Spectrex Fire Simulator Model 20/20-312 to the target point of the detector (see Fig. 22), in a way that the radiation emitted by it is facing directly towards the detector. (See appendix E)
- 3 Press the operation button once. After few seconds the Alarm LED should be on for few seconds. The 4-20mA output should turn to 15mA for a few seconds and then to return to 5mA. The Alarm Relay should also turn on during this period. The Accessory Relay should respond in parallel to the Alarm Relay if SW1-4 is OFF.

This completes the installation procedure. The detector and system are now ready for operation.

### **7.5 Safety Precautions**

After Powering-up, the detector requires hardly any attention in order to function properly, but the following should be noted:

- 1 Follow the instructions in the manual and refer to the drawings and specifications issued by the manufacturer.
- 2 Do not expose the detector to radiation of any kind unless required for testing purposes.
- 3 Do not open the detector housing, while power is supplied.
- 4 Do not touch internal parts other than the three functional switches. Interference with internal circuits may impair detector performance and will invalidate manufacturer's Warranty.
- 5 Disconnect external devices, such as automatic extinguishing systems before carrying out any maintenance.

## 8. Maintenance Instructions

### 8.1 Scope

This chapter deals with preventive maintenance, describes possible faults in detector operation and indicates corrective measures. Ignoring these instructions may cause problems with the detector and may invalidate the warranty. Whenever a unit requires service, please contact the manufacturer or its authorized distributor for assistance.

### 8.2 Maintenance Instrumentation and Personnel

The detectors' maintenance requires ordinary tools and qualified personnel, who should be familiar with local codes and practices.

### 8.3 Preventive Maintenance Procedures

The detector must be kept as clean as possible. The viewing window and the reflector of the Model 20/20R Flame Detector must be cleaned on a periodic basis. The frequency of cleaning operations depends upon the environmental conditions and specific applications. The fire detection system designer will give his recommendations. Use of the optional AIR SHIELD Model 20/20-920 is highly recommended and will help to keep the window clean and prevent dirt from accumulating on the window.

- 1 Disconnect power to the detector before proceeding with any maintenance including lens cleaning.
- 2 To clean the detector viewing window and reflector use water and detergent, rinse with clean water.
- 3 Where dust, dirt or moisture accumulates on the window, first clean with a soft optical cloth and detergent, and then rinse with clean water.

### 8.4 Periodic Maintenance Procedures

In addition to preventive cleaning and maintenance, the detector should be functionally tested every six months. This test should also be carried out for any reason the detector has been opened.

#### 8.4.1 Power-Up Procedure

Perform Power-Up procedure every time power is restored to the system. Follow the instructions in paragraph 7.2.

#### 8.4.2 Functional Test Procedure

Perform a functional test of the detector as described in paragraph 7.4.

### **8.5 Maintenance Records**

It is recommended to record maintenance operations performed on a detector in a system Log-book. The record should include information, which identifies the unit, the installation date, contractor, and entries for every maintenance operation performed including the description of the operation, date and personnel ID. If a unit is sent to the manufacturer or distributor for service, a copy of the Maintenance records should accompany it.

### **8.6 Troubleshooting**

#### **8.6.1 Fault Indication**

- 1 Check power supply for correct voltage, polarity and wiring.
- 2 Check detector window and reflector for cleanness. If necessary clean the window as indicated in paragraph 8.3 and repeat the test.
- 3 Disconnect the power supply to the system and check the detector's internal wiring.
- 4 Reconnect power supply and wait approximately 60 seconds. Repeat the test. If the indication LED is still flashing, the unit requires service .

#### **8.6.2 False Alarm or Warning Indication**

- 1 Disconnect the power supply from the system and check internal wiring.
- 2 Reconnect power supply and wait approximately 60 seconds. If indication remains, the unit requires service.



## Appendix A - Wire Selection Tables

### General Instructions For Electrical Wiring

1. Refer to Table 13 to determine the required wire gauge for general wiring, such as relay wiring. Calculate the permitted voltage fall with respect to loads current, wire gauge and length of wires.
2. Refer to Table 14 to select wire gauge for power supply wires. DO NOT connect any circuit or load to detectors' supply inputs.

**Table 13: Maximum DC resistance at 68 F for copper wire**

AWG #	mm <sup>2</sup>	Ohm per 100 ft.	Ohm/100 meter
26	0.12 - 0.15	4.32	14.15
24	0.16 - 0.24	3.42	11.22
22	0.30 - 0.38	1.71	5.60
20	0.51 - 0.61	1.07	3.50
18	0.81 - 0.96	0.67	2.20
16	1.22 - 1.43	0.43	1.40
14	1.94 - 2.28	0.27	0.88
12	3.09 - 3.40	0.17	0.55
10	4.56 - 6.64	0.11	0.35

- A. Select "Number of detectors" connected in one circuit.
- B. Select "wiring length" per your installation requirements.
- C. Refer to "power supply range" for voltage extreme applied.

**Table 14. Wiring length in feet (meter)**

No. of Detectors	Recommended Wire Diameter (AWG)					Power Supply Range (VDC)
24	18	16	14	-	-	22-32
20	18	16	14	-	-	22-32
16	20	18	16	14	-	22-32
12	20	18	16	14	-	20-32
8	20	18	16	14	-	20-32
4 and less	20	18	16	16	14	20-32
Feet (meter)	164 (50)	328 (100)	492 (150)	656 (200)	820 (250)	
	Max. Length from Power Supply to Last Detector					



## Appendix B – Typical Wiring Configurations

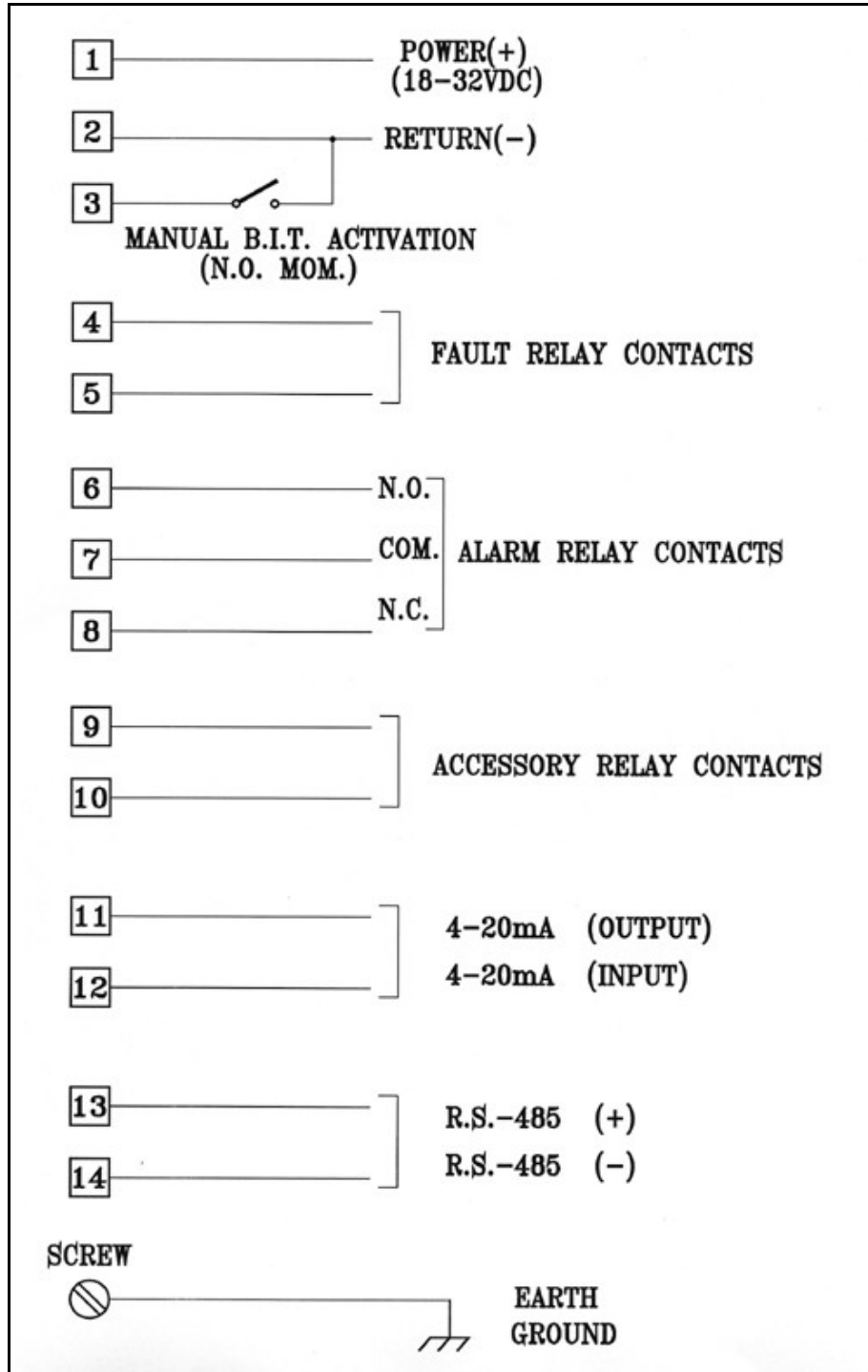

Figure 13: Flame Detector Wiring Diagram

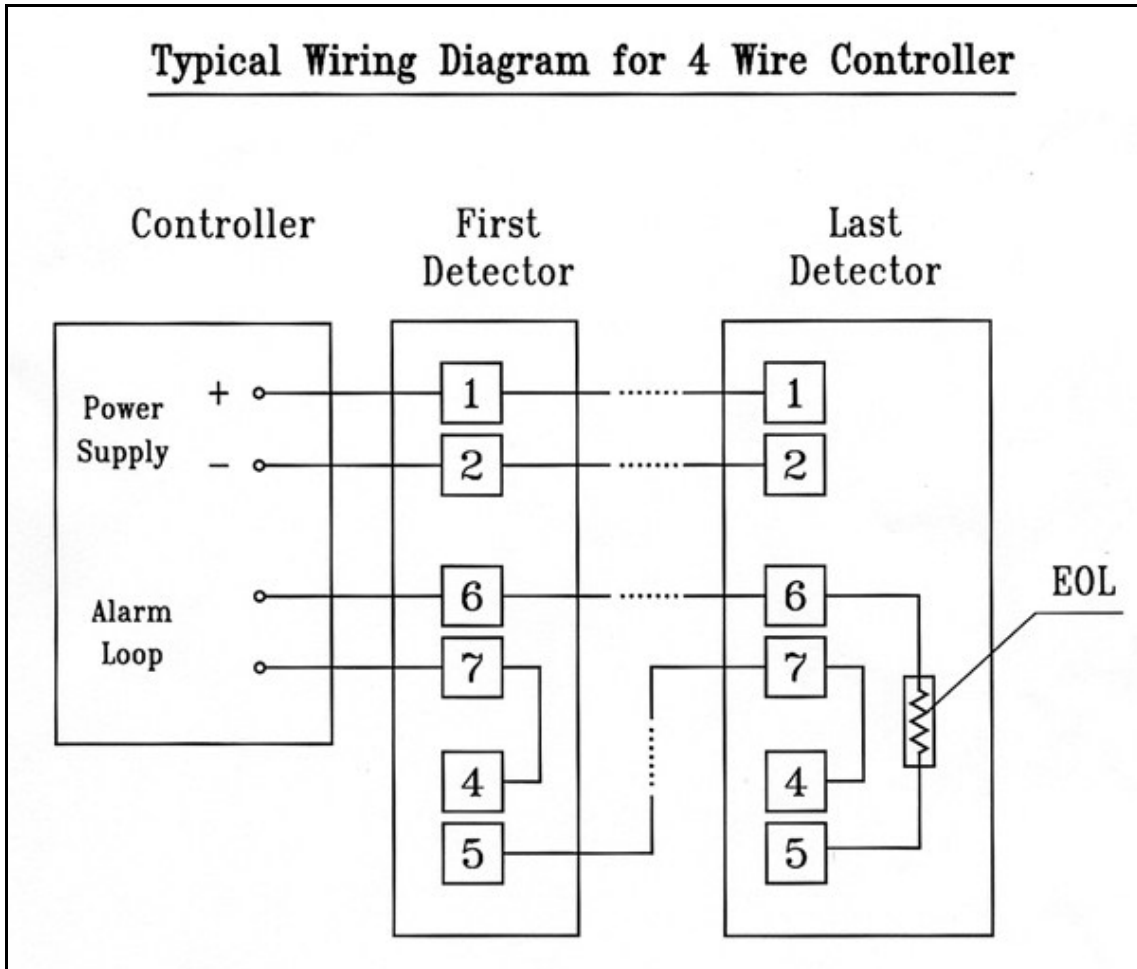
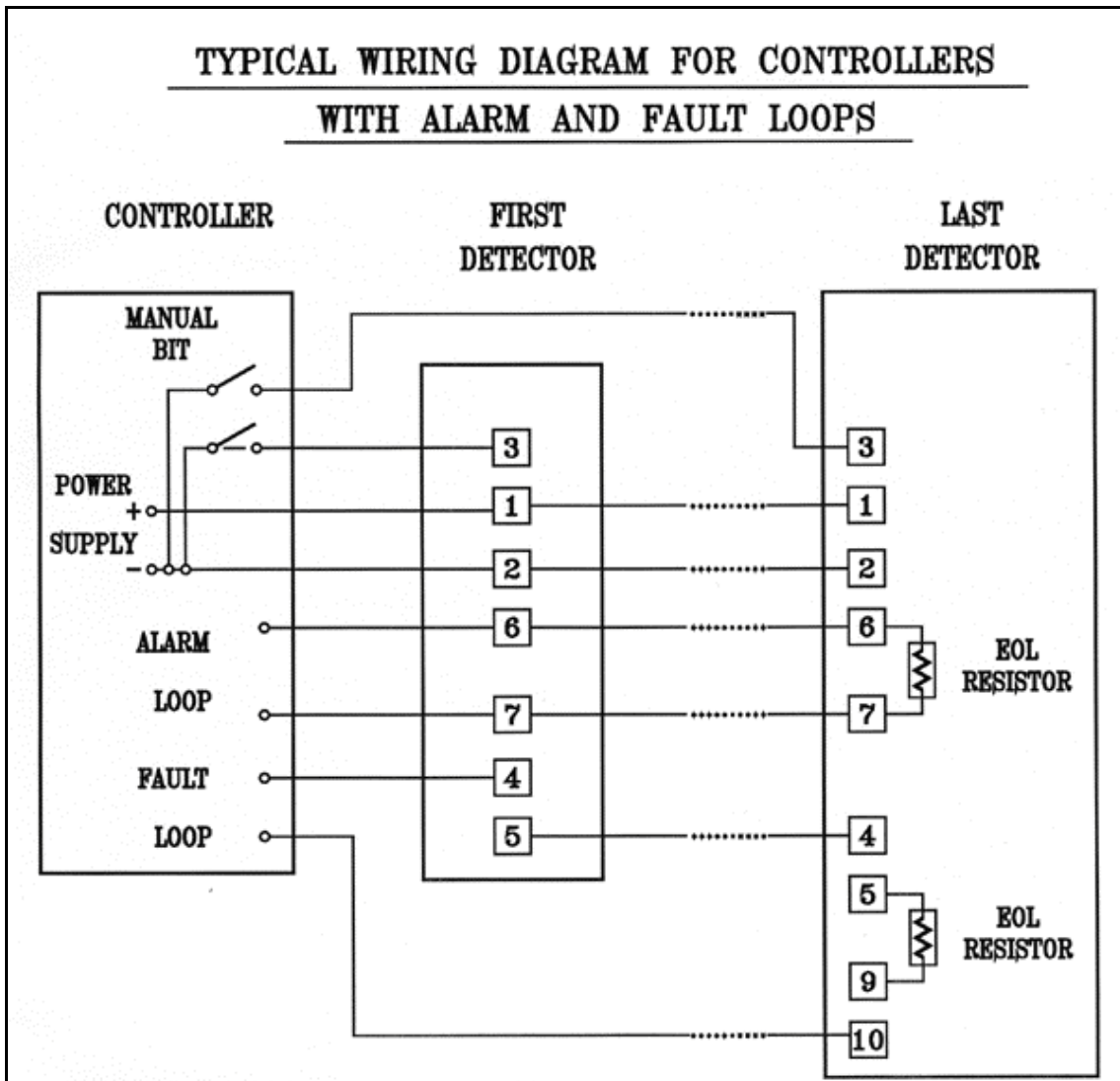

Figure 14: Typical wiring diagram for 4 wire controllers



*Figure 15: Typical wiring diagram for controllers with alarm & fault loops*

**Notes:**

1. For EOL Resistors Values See Controller Manual
2. The Accessory Relay in The Last Detector Should be Configured as an EOL (Switch SW1-8 "ON")

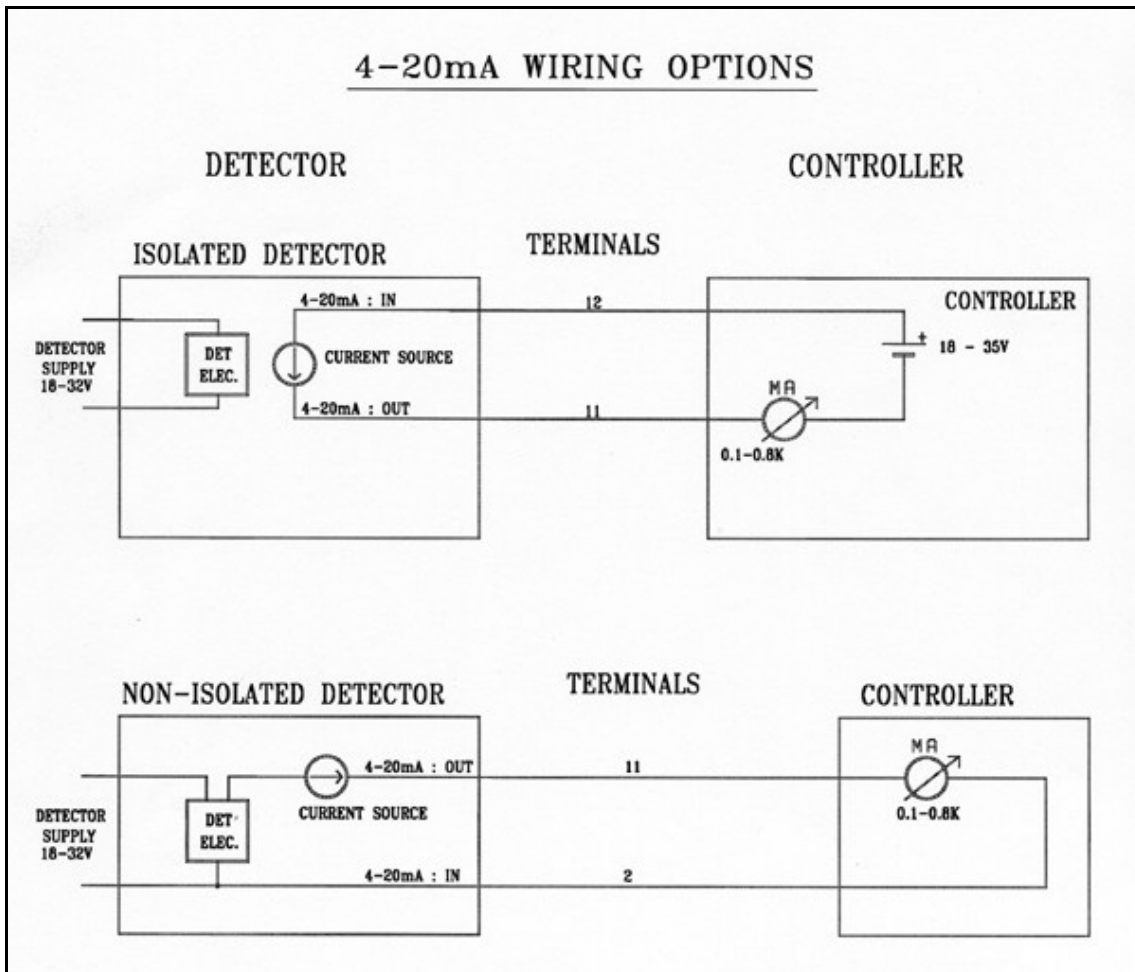

*Figure 16: 4-20mA wiring*

**Notes:**

The detectors are factory set to isolated 4-20mA 'sink' version.

To work at non-isolated 4-20mA version ("source"), connect Terminal 12 to Terminal 1. The 4-20mA meter is connected between Terminal 11 and Terminal 2.

## Appendix C – RS-485 Communication Network

Using the RS-485 network capability of the IR detector and additional software it is possible to connect up to 32 detectors in an addressable system with 4 wires only (2 for power & 2 for communication). Using repeaters, the number of detectors can be much larger (32 detectors for each repeater) on the same 4 wires. When using the RS-485 network it is possible to read each detector status (FAULT, WARNING, ALARM) and to initiate a BIT to each detector individually.

Fore more details, consult the factory.

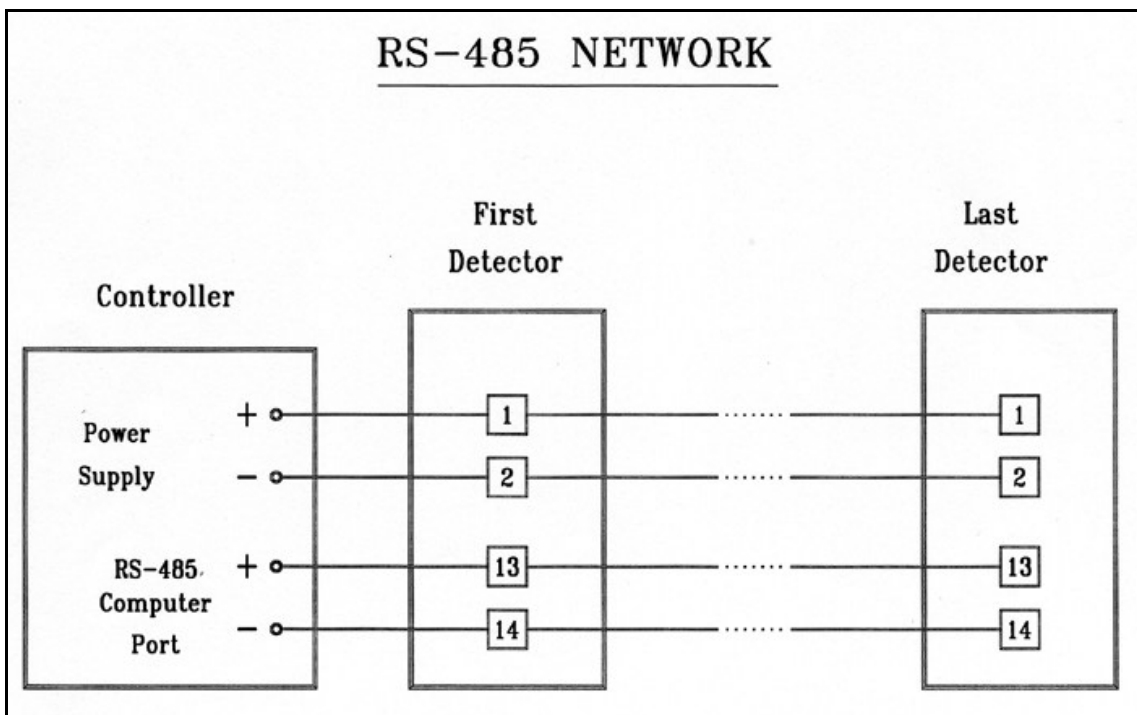

Figure 17: RS-485 networking



## Appendix D - Mounting the “EExde approved” version

The EExde approved version provides an additional EExe terminal box attached below the EExd detector and therefore allows easier access for wiring in difficult environments and hazardous areas (see fig. 18). The unit is prewired to the terminals in the additional EExe terminal section ready for field wiring connections

### 1. Detector Mounting

The detector may be mounted on a simple fabricated bracket, or preferably the optional Swivel Mount, Model 20/20-003. The Swivel Mount enables the detector to be rotated up to 40 degrees in all directions.

**1.1 Swivel Mount Kit** - Use the kit from the paragraph 6.5.1

### 1.2 Swivel installation

- 1 **Refer to Fig.8 and Fig 9.** Place the swivel mount (item 6) in its designated location and secure it with four (4) M6 or 1/4" screws (item 11) (recommended), placed 3.0 in. (76.2 mm.) apart on the swivel mount plate (item 10).

**Note:** Skip this step if the Swivel Mount is already installed. Also detector removal for maintenance purpose does not require Swivel Mount removal.

- 2 Unpack the detector.
- 3 Place the detector, with its conduit inlets pointing down, on the holding plate of the swivel mount (Fig. 8 item 7). Secure the detector by four (4) M6 screws with M6 spring washers from the Swivel Mount Kit using the holes (Fig. 9 item 5). You can use the thread on the modified cover (Fig. 18 item 1) marked either triangle symbol or square symbol. Use No. 5 Hex Key for M6 screws.
- 4 Tighten the three locking 3/8"-24UNF screws (Fig. 9 item 8) of the swivel mount ring until the friction in the ball joint holds the detector in its position. Yet, still permits it to be moved by hand-applied force (Use 3/16" HEX KEY).
- 5 Point the detector towards the protected area and make certain that the view of the area. Secure the detector in that position by tightening the locking screws (Fig.9 item 8) of the swivel mount ring.

The detector is now correctly located and aligned and ready for connecting to the system.

**2. WIRING (REFER TO FIG. 18.)**

- 1 Disconnect power.
- 2 Release the four (4) slotted-head screws (item 3) that secure the chamber cover (Item 2). The chamber is now revealed.
- 3 Remove the protective plug mounted on the detector electrical entry, pull the wires through the detector chamber (Item 7). Use a 3/4"-14NPT or M25x1.5 explosion-proof conduit / cable gland connection to assemble the conduit / cable to the detector.
- 4 Connect the wires to the required terminals (Item 4) according to the wiring diagram. See paragraph 2.1 and figures no. 19 and no. 20.
- 5 Connect the grounding wire to the ground screw outside the detector cover (Item 5).

**The detector must be well grounded to *Earth Ground* for proper operation.**

- 6 Verify the wiring. Improper wiring may damage the detector.
- 7 Check the wires for secure mechanical connection and press them neatly against the terminal to prevent them from interfering while closing the cover (Item 2).
- 8 Place and secure the cover chamber (Item 2) using four (4) slotted-head screws (Item 3).

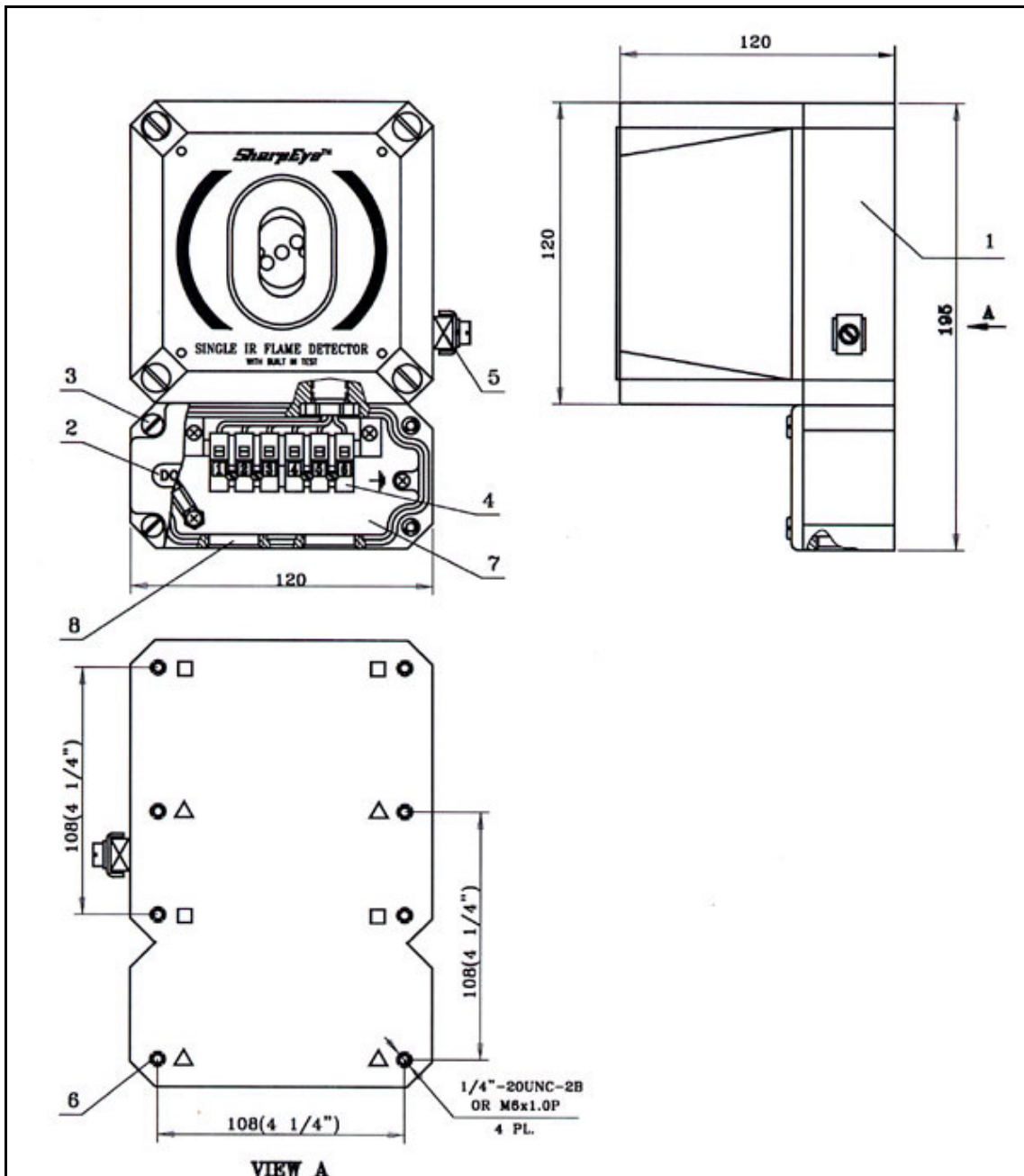

Figure 18: Flame Detector Assembly - Wiring Diagram

Description	
1. Modified Back Cover	5. Ground Terminal
2. EExe Chamber Cover	6. Mounting Thread
3. Slotted Screw	7. EExe Chamber
4. Terminal Block	8. Conduit Inlet

### 2.1 Terminal Wiring

The detector contains an EExe chamber consisting of a terminal block (Item 4). The terminal block is labeled 1 to 6. **(See Fig. No.18)**

The following describes the function of each electrical terminal of the detector:

There are two options:

RS-485 & 4-20mA Version Option A (See Fig. No. 19)	Alarm & Fault Relays Version Option B (See Fig. No. 20)
<p><b>Power Supply</b> (Terminal Numbers 1, 2): Input power - Terminal No. 1. RETURN - Terminal No. 2.</p>	<p><b>Power Supply</b> (Terminal Numbers 1, 2): Input power - Terminal No. 1. RETURN - Terminal No. 2.</p>
<p><b>RS-485</b> (Terminal Numbers 3, 4): Terminal Numbers 3 and 4 are used for communication network as specified in appendix C. Terminal No. 3 - positive (+) lead. Terminal No. 4 - negative (-) lead.</p>	<p><b>Alarm Relay</b> (Terminal Numbers 3, 4): The Alarm output is a NO. SPST contact at Terminal Numbers 3 and 4. The contacts are closed at Alarm Mode.</p>
<p><b>4-20mA Output</b> (Terminal Numbers 5, 6): Terminal Numbers 5 and 6 are used for analog, 4-20mA current output as specified in paragraph 5.e Terminal No. 5 is used as output Terminal. Terminal No. 6 is used as input Terminal. (see appendix B for more details)</p>	<p><b>Fault Relay</b> (Terminal Numbers 5, 6): The Fault output is N.C. SPST contact at Terminal Numbers 5 and 6. The contacts are open at Fault condition.</p>
<p><i>Figure 19: OPTION A Flame Detector Assembly - Wiring Diagram (“de version”)</i></p>	<p><i>Figure 20: OPTION B Flame Detector Assembly - Wiring Diagram (“de version”)</i></p>

## Appendix E - IR Fire Simulator

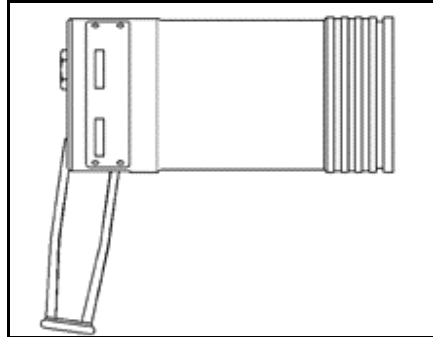

*Figure 21: Fire Simulator*

### *Product Description*

The SharpEye IR Long Range Fire simulator 20/20-312 is designed specifically for use with the IR flame detectors. The Fire Simulator emits IR radiation in a unique sequential pattern corresponding and recognizable by the IR detector as fire. This allows the IR detectors to be tested under real fire conditions without the associated risks of an open flame.

### *Unpacking*

In addition to the delivery form, there should be the following contents:

- Fire Simulator with built in batteries
- Battery charger
- Optional Beam Collimator
- Storage Case

### *Operating Instructions*

#### **WARNING:**

Do not open the Fire Simulator to charge the batteries or for any other reason in a hazardous area.

#### **CAUTION:**

The following test will simulate a real fire condition and may activate the extinguishing system or other alarms. If this is not desired, disconnect them before the test and reconnect after the simulation.

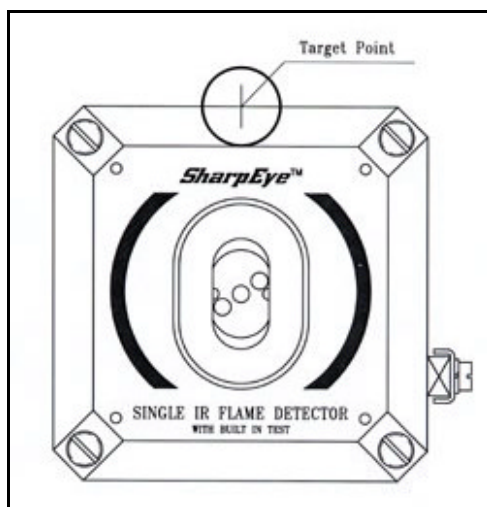

*Figure 22: IR Detector Target Point*

**Follow these instructions to simulate a fire:**

1. Aim the Fire Simulator towards the detector's "Target Point".
2. For testing keep a distance of at least 20 inches (50cm) from the detector.
3. Press the operation button once. Fire simulation will last for 20 seconds. The detector will send an alarm signal (solid red LED).
4. For another fire simulation, a 20 second time lapse is required between tests.
5. Make sure the optical window is clean and keep the Fire Simulator in a safe place when not in use.

**Battery Charging**

The Fire Simulator uses NiCd batteries as a rechargeable power source. When the batteries are fully charged it will operate for at least 60 uses without recharging. An internal buzzer is sounded when the voltage from the batteries is lower than the required operational level.

1. Place the Fire Simulator on a table in a safe area.
2. Turn the sealed plug (next to the operation button) counter-clockwise with a suitable wrench.
3. Connect the battery charger.
4. Charge for a maximum of 14 hours.
5. Disconnect the charger.
6. Tighten the sealed plug clockwise.

## Specifications

Mechanical		
Explosion Proof Enclosure:		
NFPA (designed to meet) Class I, Division 1 & 2 Groups B, C and D Class II, Division 1 & 2 Groups E, F, and G		
ATEX (designed to meet) EX II2G EExd IIB T5 50 C per En 50-014 & EN50-018		
Electrical		
Power: 8 VDC Max. 6 x Rechargeable 1.2 VDC NiCd Batteries		
Current: 2.5A Avg.		
Charge: 400mA for 14 Hours		
Environmental		
Temperature Range: -4° F (-20° C) to 122° F (50° C)		
Vibration Protection: 1g (10-50hz)		
Water and Dust: IP 67 per EN 60529		
Physical		
Dimension: 11.5 x 10.1 x 3.9 in (292 x 258 x 100 mm)		
Weight: 7.5 lb. (3.4 Kg)		
Range*		
<u>Sensitivity</u>	<u>Range</u>	<u>Standard</u>
1 (Low)	16.5 ft ( 5 m)	-
2 (High)	50 ft (15 m)	2.4 ft (0.75 m)

\* The minimum distance from the detector is 20 inches (50cm)

\* At extreme temperatures - 15% Max. Reduction in range

For additional details or assistance, please contact

GasTech Australia Pty Ltd  
24 Baretta Rd  
Wangara Western Australia 6065  
Tel 1800 999 902  
Fax 1800 999 903  
<http://www.gastech.com.au>

