

Sample-Draw Transmitter Operator's Manual



GasTech Australia Pty Ltd
24 Baretta Rd
Wangara Western Australia 6065
Tel 1800 999 902
Fax 1800 999 903
<http://www.gastech.com.au>



PROPRIETARY STATEMENT

Thermo GasTech owns proprietary rights in the information disclosed within. By receiving this document, the recipient agrees that neither this document nor the information disclosed within nor any part shall be reproduced or transferred to other documents or used or disclosed to others for manufacturing or for any other purpose except as specifically authorized in writing by **Thermo** GasTech.

COPYRIGHT STATEMENT

Information contained in this document is protected by copyright. No part of this document may be photocopied, reproduced, or translated to another program or system without prior written authorization from **Thermo** GasTech., © 2000, **Thermo** GasTech.

TRADEMARK STATEMENT

Protected through use and/or registration in the United States and many foreign countries are the trademarks and service marks of **Thermo** GasTech. The use of the ® symbol indicates registration in the United States only; registrations may not have been issued at present in other countries. All other product names and logos are trademarks of their respective owners.

GASTECH® is a trademark of **Thermo** GasTech and is registered with the U.S. Patent and Trademark Office.

DISCLAIMER

Under no circumstances will **Thermo** GasTech be liable for any claims, losses, or damages resulting from or arising out of the repair or modification of the equipment by a party other than **Thermo** GasTech or its authorized service representatives, or by operation or use of the equipment other than in accordance with the printed instructions provided by **Thermo** GasTech or if the equipment has been improperly maintained or subject to neglect or accident. Any of the foregoing will void the warranty.

EXPORT STATEMENT

Export of the information and products in this manual from the U.S.A., or re-export from another country, may require written authorization from the U.S. Department of Commerce. Printed in the U.S.A.

REVISIONS TO MANUAL

All information contained in this manual is believed to be true and correct at the time of printing. However, as part of its continuing efforts to improve its products and their documentation, **Thermo** GasTech reserves the right to make changes at any time without notice. Any revised copies of this manual can be obtained by writing **Thermo** GasTech.



WARNING



THIS INSTRUMENT IS DESIGNED TO DETECT ONE OR MORE OF THE FOLLOWING:

FLAMMABLE VAPORS, OXYGEN CONTENT, AND/OR TOXIC GAS AND TO GIVE WARNING BEFORE THEY REACH HARMFUL CONDITIONS. IN ORDER TO ENSURE THAT IT WILL WARN OF DANGEROUS CONCENTRATIONS, IT IS ESSENTIAL THAT THE INSTRUCTIONS IN THIS MANUAL, PARTICULARLY THOSE CONCERNING START UP, OPERATION, CALIBRATION, AND MAINTENANCE, BE READ, UNDERSTOOD, AND FOLLOWED.

NOTATION CONVENTIONS

Notices are used in this operator's manual to alert you to hazardous conditions to person or instrument and to notify you of additional information. This operator's manual uses the following notices.



WARNING

Notifies you of potential danger that can result in personal injury or death.



CAUTION

Notifies you of potential damage to equipment.



NOTE

Notifies you of additional or critical information.



SERVICE POLICY

Thermo GasTech maintains an instrument service facility at the factory as well as authorized service facilities around the world. Should your instrument require service, you may contact us toll free at **1-877-GASTECH (427-8324)** for US only or **1-510-745-8700**, or visit our website www.thermogastech.com for authorized service locations.

For warranty or non-warranty repairs, call us to complete a Return Material Authorization (RMA) form, obtain billing and shipping information and tell us the nature of the problem. For non-warranty repairs, you will need to provide a purchase order number. If you need to set a limit to the repairs costs, state a “Not to Exceed” figure. If you need a quotation before you can authorized the repair costs, so state, but understand this will incur additional costs and may delay processing of the repair.

You may send the unit, prepaid, to: **Thermo GasTech, 8407 Central Ave., Newark, CA 94560-3431, Attn.: Service Department.** Enclose the copy of the RMA (Return Material Authorization) that was previously faxed to you. Pack the instrument and all its accessories (preferably in its original packing) and any special instructions.

Repairs are warranted for 90 days from the date of shipment. Sensors have individual warranties.



NOTE

Thermo GasTech assumes no liability for work performed by unauthorized service facilities.

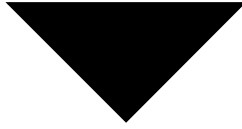

WARRANTY STATEMENT

Thermo GasTech (the “Company”) warrants that the Products will operate substantially in conformance with the Company’s published specifications, when subjected to normal, proper, and intended usage by properly trained personnel, for a period of one (1) year after shipment to Customer (the “Warranty Period”). The Company agrees during the Warranty Period, provided it is promptly notified in writing upon the discovery of any defect and further provided that all costs of returning the defective Products to the Company are prepaid by Customer, to repair or replace, at the Company’s option, defective products so as to cause the same to operate in substantial conformance with said specifications. Replacement parts may be new or refurbished, at the election of the Company. All replaced parts shall become the property of the Company.

Lamps, pump diaphragms/valves, batteries, fuses, bulbs, and other expendable items are expressly excluded from the warranty.

The Company’s sole liability with respect to equipment, materials, parts, or software furnished to the Company by third party suppliers shall be limited to the assignment by the Company to Customer of any such third-party supplier’s warranty, to the extent the same is assignable. In no event shall the Company have any obligation to make repairs, replacements, or corrections required, in whole or in part, as the result of (i) normal wear and tear, (ii) accident, disaster, or event of force majeure, (iii) misuse, fault, or negligence of or by Customer, (iv) use of the Products in a manner for which they were not designed, (v) causes external to the Products such as, but not limited to, power failure or electrical power surges, or (vi) use of the Products in combination with equipment or software not supplied by the Company.

ANY INSTALLATION, MAINTENANCE, REPAIR, SERVICE, RELOCATION, OR ALTERATION TO OR OF, OR OTHER TAMPERING WITH, THE PRODUCTS PERFORMED BY ANY PERSON OR ENTITY OTHER THAN THE COMPANY WITHOUT THE COMPANY’S PRIOR WRITTEN APPROVAL, OR ANY USE OF REPLACEMENT PARTS NOT SUPPLIED BY THE COMPANY, SHALL IMMEDIATELY VOID AND CANCEL ALL WARRANTIES WITH RESPECT TO THE AFFECTED PRODUCTS.

THE OBLIGATION TO REPAIR OR REPLACE A DEFECTIVE PRODUCT SHALL BE THE SOLE REMEDY OF CUSTOMER IN THE EVENT OF A DEFECTIVE PRODUCT. EXCEPT AS EXPRESSLY PROVIDED IN THIS SECTION, THE COMPANY DISCLAIMS ALL WARRANTIES, WHETHER EXPRESS OR IMPLIED, ORAL OR WRITTEN, WITH RESPECT TO THE PRODUCTS, INCLUDING WITHOUT LIMITATION ALL IMPLIED WARRANTIES OF MERCHANTABILITY OR FITNESS FOR ANY PARTICULAR PURPOSE. THE COMPANY DOES NOT WARRANT THAT THE PRODUCTS ARE ERROR-FREE OR WILL ACCOMPLISH ANY PARTICULAR RESULT.

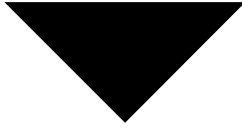



TABLE OF CONTENTS

Chapter 1

Introduction

Overview	1
Description	1
Target Gases	2
Specifications	3

Chapter 2

Installation

Mounting the Transmitter	5
Connecting the Sample Lines	6
Wiring the Transmitter	7

Chapter 3

Start Up & Operation

Preparing for Start Up	9
Setting the Channel Parameters at the Controller	9
Setting the Fresh Air Signal	10

Chapter 4

Calibration

Preparing for calibration	12
Calibrating the Detector	12

Chapter 5

Maintenance

Preventive Maintenance	17
Troubleshooting	18
Replacing the Toxic or Oxygen Sensor	22
Replacing the Combustible Gas Sensor	23
Replacing the Toxic and Oxygen Amplifier	24
Replacing the Combustible Amplifier	25
Replacing the Pump	26

Appendix A

Parts List 27

Appendix B

External Wiring Instructions 31

Appendix C

Calibration Response Charts 35



Chapter
1

INTRODUCTION

Overview

The Sample-Draw Transmitter is a series of oxygen, combustible gas, and toxic gas transmitters.

Description

The Sample-Draw Transmitter assembly is comprised of a sample-drawing apparatus, main board, gas sensor, a temperature compensation circuit, and an amplifier/transmitter electronic assembly all enclosed in a weather and dust resistant housing.

Target Gases

Table 1-1 lists the target gas and detection ranges for the Sample-Draw Transmitter.

Table 1-1 Target Gases and Detection Ranges

Target Gas	Detection Range
Ammonia	0 to 100 ppm
Arsine	0 to 1 ppm
Carbon Monoxide	0 to 500 ppm
Chlorine	0 to 10 ppm
Chlorine Dioxide	0 to 2 ppm
Diborane	0 to 1 ppm
Fluorine	0 to 10 ppm
Hydrogen Chloride	0 to 30 ppm
Hydrogen Cyanide	0 to 50 ppm
Hydrogen Fluoride	0 to 10 ppm
Hydrogen Sulfide	0 to 100 ppm
Nitric Oxide	0 to 100 ppm
Nitrogen Dioxide	0 to 20 ppm
Oxygen	0-30% vol
Ozone	0 to 1 ppm
Phosphine	0 to 1 ppm
Silane	0 to 20 ppm
Sulfur Dioxide	0 to 20 ppm
Combustible gases	0 to 100% LEL ¹

¹. Lower Explosive Limit (may also be used in ranges of 0 to 5,000 or 10,000 parts per million for some hydrocarbons).

Specification

Table 1-2 lists the Sample-Draw Transmitter performance, electrical and environmental specifications.

Table 1-2 Specifications

Amplifier Outputs	4 to 20 mA analog signal (to controller) 100 to 500 mV analog test signals (at test jacks)
Fault Condition	0 mA loop current
Sampling Method	Sample-Draw
Accuracy	± 10% detection range
Repeatability	± 5% detection range
Housing	Fiberglass (with Lexan ¹ window), NEMA 4X
Dimensions	10.0 in. H x 7.15 in. W x 4.5 in. D (25.4 cm H x 18.2 cm W x 11.4 cm D)
Weight	4 lbs (1.8 kg)
Enclosure Rating	NEMA 4X
Area Classification	Non-hazardous locations
Power Source	12 to 24V DC
Temperature Range	- 4° F to 113° F (-20° C to 45° C)
Standard Accessories	Manual In-line hydrophobic filter (some versions) ²
Optional Accessories	Calibration kits, gas cylinders, gas collection bag

¹. Lexan is a registered trademark of General Electric Company.

². This filter is not furnished for use with reactive gases Cl₂, ClO₂, F₂, HCl, HF, NH₃, NO₂ and O₃. These gases react with or are absorbed by entrapped water or other residue, and thus would be lost prior to entering the sample-drawing system.

INSTALLATION

Mounting the Transmitter



WARNING

Perform all installation procedures in a fresh air environment (known to be free of combustible and toxic gases and of normal oxygen content). The transmitter is not in operation as a gas monitoring system until the start-up procedure is complete.



CAUTION

The Sample-Draw Transmitter is not suitable for Class I hazardous areas. Mount the Sample-Draw Transmitter in a non-hazardous area

1. Select a mounting area that is indoors or sheltered from rain or snow. Make sure there is enough room to mount the housing, open the housing door, and to make wiring and sample line connections at the bottom of the housing.
2. Secure the housing to the vertical surface using bolts or screws through the mounting flanges (see Figures 2-1).

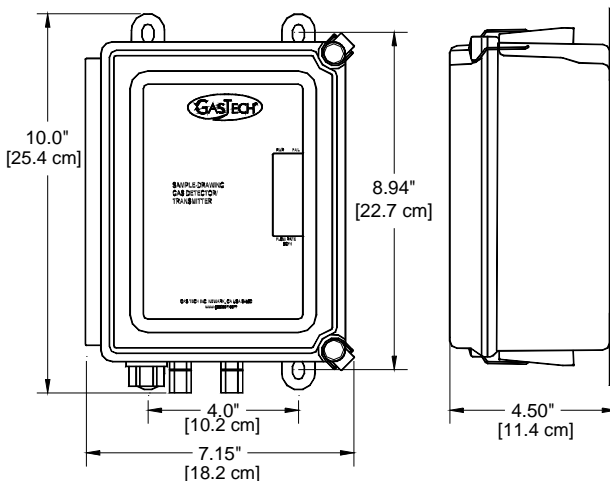

Figure 2-1 Outline and Mounting Dimensions

Connecting the Sample Lines

Refer to Figure 2-2 Flow Diagram and Figure 2-3 for Inlet and Outlet connections.

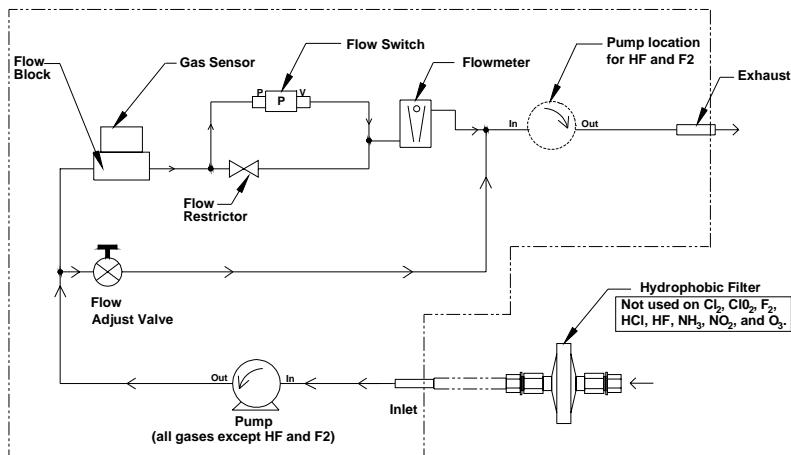

Figure 2-2 Flow Diagram

1. Attach 1/4 in. OD TEFLON® tubing to the inlet fitting. The other end of the tubing should be at the monitoring location.
2. If supplied, insert the filter into the incoming sample line at a point near the inlet fitting, of the sample-draw transmitter.
3. If necessary, connect a 1/4 in. OD plastic or stainless steel tube to the EXHAUST fitting. Keep the exhaust tubing as short as possible. Route the exhaust to an open area where the sample can safely dissipate.

®DuPont registered trademark.

Wiring the Transmitter

Use a three-conductor, shielded cable, or run the wiring within metal conduit to reduce Radio Frequency Interference (RFI) and Electromagnetic Interference (EMI).

Use 18 AWG wire or larger. The two-way wire and receiver resistance must not exceed 200 ohms for 12 volts systems or 600 ohms for 24 volts systems.



WARNING

Make sure all power to the controller is turned off during all wiring procedures.

- The power circuit (“+12-24 volts” and “—”) supplies both the flow system (pump and signal LEDs) and the signal loop circuit.
- The signal loop circuit (amplifier/transmitter plus all external components such as controller, displays, etc.) all of which share the common 4-20 mA current loop, which begins at “+12-24 volts” and terminates back at controller common “—”.



WARNING

Do Not Overload the Transmitter Signal loop or signal limiting due to excessive loop resistance could result in understatement of hazardous conditions. From Ohm’s Law, a signal loop powered from a 12 volt source cannot deliver more than 20 mA (full scale reading) if the total loop resistance, including all wiring, this transmitter (25 ohms internal), the receiver, and all other loop device input circuits, exceed 600 ohms. Operation from 24 volts permits about twice the loop resistance. Do not operate from voltages below 12 volts.



CAUTION

Do not run transmitter and AC power wiring through the same conduit.

1. Connect the sample-draw transmitter to the receiver, controller or other 12-24 volt DC power source.

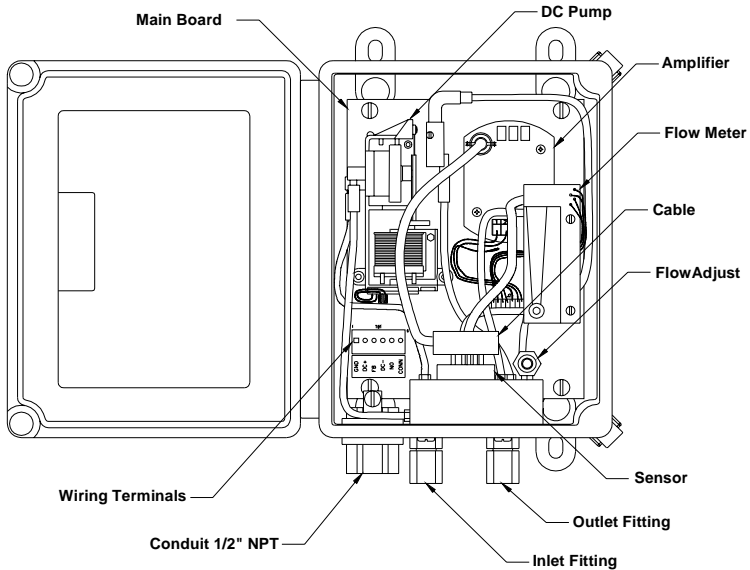

Figure 2-3 Component Location

2. Ground the shield cable or metal conduit by connecting it to the SHIELD or GND terminal at the receiver or controller. Do not ground any of the three power/signal terminals in the sample drawing transmitter to its housing.
3. Confirm that the detector is connected to the amplifier.
4. Confirm that the terminal block on the amplifier is connected to the PC board cable.
5. Turn on the power to the system at the power source.
6. Confirm that the flowmeter "PILOT" light is on and the flowmeter indicates a flow rate of approximately 0.6 SCFH. Adjust if necessary.
7. Confirm that the incoming sample line is not leaking. To test the sample line, put your thumb over the end of the incoming sample tubing. If the flowmeter ball drops to the bottom of the column and the flow fail circuit activates, the sample tubing is ready to use.



CAUTION

Always ground the cable or conduit at the controller and never at the transmitter.

START UP & OPERATION

Complete the following procedure to place the controller and the transmitter into normal operation.

Preparing for Start Up

1. Complete the mounting and wiring procedures described in the Installation chapter of this manual.
2. Connect incoming power to the controller as described in the receiver or controller manual.



NOTE

Allow the sensor to stabilize for 1 hour after power is introduced before calibrating.

Setting the Channel Parameters at the Controller

The sample drawing transmitter may be used with a wide variety of receivers and controllers which provide 12 to 24 volts DC power at 400 mA and a means of accepting and interpreting a 4-20 mA signal proportional to gas concentration in the ranges shown in Table 1-1 of this manual

When you install the transmitter, set the parameters for that channel at the controller. For instructions on setting the channel parameters at the controller, see the receiver or controller manual.

Setting the Fresh Air Signal



WARNING

If you suspect the presence of target gas during the start-up procedure, use the calibration kit described in the calibration chapter and the zero-emission air cylinder to introduce fresh air to the detector and confirm an accurate zero setting (span setting for oxygen monitoring systems).

1. Confirm that the receiver, controller or DC power source are on.
2. Open the housing cover.



NOTE

Some controllers have a feature that enables you to disable the alarm LEDs, buzzer, and relays during the calibration procedures, response tests, and so on. Refer to the controller manual for information. Make sure you re-enable full alarm functionality after the calibration procedure is complete.

3. Confirm that the sample line inlet is sampling from a source of clean air.
4. Select the millivolt (mV) range on the multimeter. Plug the positive multimeter lead into the white (+) test jack: plug the negative lead into the blue (-) test jack.
5. Confirm a reading of 100 mV (toxic/combustible) or 379 mV (oxygen) on the multimeter. Adjust the potentiometer on the amplifier if necessary.
 - Toxic/combustible - Adjust “ZERO” pot until the multimeter reading is 100 mV
 - Oxygen - Adjust “SPAN” pot until the multimeter reading is 379 mV
6. Remove the multimeter leads from the test jacks, and secure the cover to the housing.

The transmitter is now in operation.

CALIBRATION

This chapter describes the optional calibration kit used for calibrating the transmitter. See Parts List, in Appendix A of this manual for ordering information.



WARNING

Accurate calibration of the transmitter is essential to ensure accurate readings of toxic gas concentrations. Incorrect calibration can impair the performance of the transmitter and place you in unnecessary danger if hazardous conditions exist.

The calibration kit contains all of the equipment you need to introduce a calibration sample to the detector. It includes the following components:

- Storage Case (safely stores the components of the calibration kit).
- Cylinder (contains a known concentration of target gas).
- Regulator (controls the flow of the sample from the cylinder to the detector)
- Tubing (connects components of the calibration kit).
- Gas collecting Bag (permits matching of regulator flow rate to the sample pump flow rate). One of two types may be furnished:
 - TEDLAR™ bag may be used for all gases.
 - Vinyl bag is suitable for Nitrogen, hydrogen, propane, hexane and carbon monoxide, or Zero Air.
- Pinch Clamp and Y fitting (controls gas flow between the gas collecting bag and transmitter).

For calibration it is preferable to introduce the calibration gas directly to the inlet of the sample line. If this is not practical, temporarily remove the sample line tubing from the Inlet fitting of the sample-draw adapter, connect a short piece of tubing in its place and admit the calibration gas there. Be sure to replace the sample line when calibration is complete.

Preparing for Calibration

This section describes how to prepare the transmitter for calibration. The procedure includes step-by-step instructions for preparing the calibration kit and the transmitter.



WARNING

Calibrate the detector in a fresh air environment (environment known to be free of toxic gases). If the in-line hydrophobic filter is used during normal operation, calibrate the detector with the filter in place.

Calibrating the Detector

This chapter describes how to prepare the gas cylinder, set the clean air base line and gas response reading for the toxic gas and oxygen transmitters.

Calculating the Calibration Gas Response Reading

The 100 to 500 mV test signal at the test jack of the transmitter amplifier is used to calibrate the transmitter. The following formula describes how to calculate the output test signal as a function of the gas concentration:

$$\text{Test signal} = ((\text{gas concentration}/\text{full scale range}) \times 400 \text{ mV}) + (100 \text{ mV})$$

- For example, if you are using a gas cylinder of 5 ppm chlorine to calibrate a transmitter whose full-scale range is 0-10 ppm:

$$((5 \text{ {ppm conc.}})/10 \text{ {ppm full-scale conc.}}) \times 400 \text{ mV {range}} + (100 \text{ mV {offset}}).$$

$$= (5/10 \times 400 \text{ mV}) + (100 \text{ mV}) = 300 \text{ mV gas signal setting on multimeter.}$$

- For oxygen, the measurement range is 0-30% by volume and the recommended calibration gas is clean air, which contains 20.9% oxygen, so the calculation is:

$$((20.9/30) \times 400) + (100) = 378.7 \text{ (or } 379) \text{ mV.}$$

For user convenience, graphs of signal versus gas concentration are shown in Appendix C of this manual for each gas range.

Preparing the Gas Cylinder

**NOTE**

When performing the following steps, use gas samples of known concentration. Cylinders of known concentration are available from **Thermo** GasTech (see Parts List in Appendix A). Specify gas and concentration when ordering gas cylinders.

1. Verify the regulator flow control valve is closed, then carefully screw the regulator onto the cylinder.
2. Verify that all tubing connections are tight and secure.

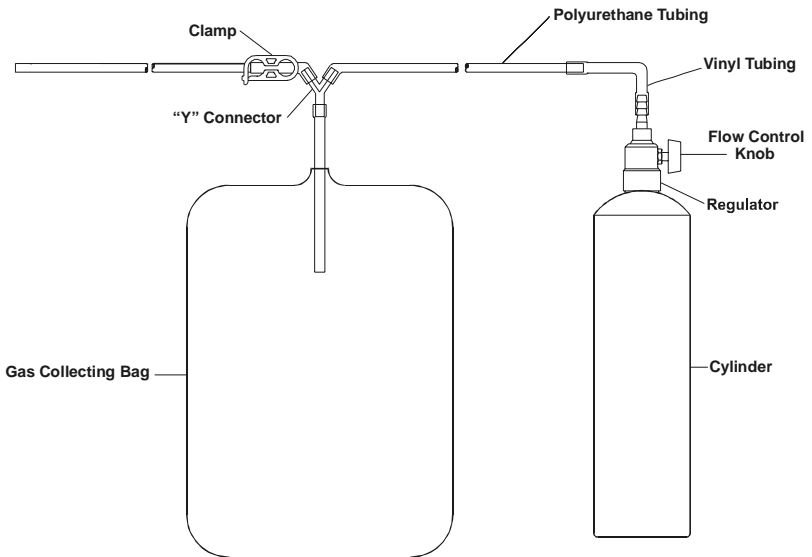

Figure 4-1 Calibration Kit with Gas Cylinder and Gas Collecting Bag

Calibrating the Toxic Gas or Combustible Detector

1. Verify the absence of toxic/combustible gas or any atmosphere other than clean air at the calibration site, by ventilation with clean air or by testing with a portable gas analyzer.
2. Open the housing.
3. Set the multimeter to 0-500 DC mV range. Plug the positive multimeter lead into the white (+) test jack and the negative lead into the blue (-) test jack of the amplifier.
4. Confirm that the multimeter shows a reading of 100 mV. If the reading is other than 100 mV adjust the ZERO potentiometer on the amplifier so that it does so. Leave the multimeter probes connected to the test jacks for setting the toxic gas response.



NOTE

For Cl₂, ClO₂, F₂, HF, NO₂ and O₃ transmitters, turn the zero control counter-clockwise to increase reading, for all other gases turn it clockwise to increase reading.

SETTING THE TOXIC OR COMBUSTIBLE GAS RESPONSE READING

1. Set the multimeter to 0-500 DC mV range. Plug the positive multimeter lead into the white (+) test jack and the negative lead into the blue (-) test jack.
2. Close the clamp, then open the flow control knob until the gas collecting bag is approximately 3/4 full.
3. Open the clamp and allow the sample-draw pump to draw gas from the gas collecting bag. Adjust the regulator so the gas collecting bag remains 3/4 full.
4. After the reading stabilizes (normally 1 to 2 minutes), confirm a reading of the SPAN pot on the amplifier until the multimeter reads the value calculated at the beginning of this section or adjust the SPAN potentiometer on the amplifier so that it does so.



CAUTION

If the reading on the multimeter has not stabilized after 2 minutes, see the Troubleshooting section of this manual for slow response.

5. Remove the multimeter test probes and secure cover to housing.
6. Close the flow control knob and disconnect the calibration gas cylinder. Flatten the gas collecting bag to expel any remaining gas.

The transmitter is now in normal operation.

Calibrating the Oxygen Detector

SETTING THE OXYGEN ZERO READING

1. Set the multimeter to 0-500 DC mV range. Plug the positive (+) multimeter lead into the white (+) test jack and the negative lead into the blue (-) test jack of the amplifier.
2. Attach the regulator to the cylinder of 100% nitrogen.
3. Connect the regulator output to the sample line inlet.
4. Observe the millivolt reading on the multimeter, which should decline towards 100 mV as nitrogen enters the detector and displaces residual air.
5. When the multimeter reading has stabilized, turn the “ZERO” pot on amplifier until reading is 100 mV.
6. Leave the multimeter connected to the amplifier test jacks.
7. Close the flow control knob on the regulator and disconnect the nitrogen cylinder. Flatten the gas collecting bag to expel any remaining gas.

SETTING THE OXYGEN RESPONSE READING

For calibration of oxygen transmitters, the recommended calibration gas is clean fresh air, if its purity can be assured by ventilation or by test with a portable oxygen indicator. If this is impractical, a cylinder of certified ZERO AIR should be used. For clean fresh air, the calibration setting should be 379 mV at the test jacks (equivalent to 15.1 mA in signal loop), to correspond with the 20.9% oxygen present in clean air. For ZERO AIR, calculate the proper span setting for the analyzed oxygen content (if other than 20.9%) from the formula or from the chart in Appendix C of this manual, then proceed as follows:

1. If using clean air for calibration, assure that the sample line inlet is relocated to a source of air known to be free of contamination, then go directly to step 5 (otherwise connect the regulator to a cylinder of certified ZERO AIR).



NOTE

The ZERO AIR cylinder is not included in the standard calibration kit, as clean air is most often readily available to the detector by normal methods of ventilation. It may be ordered separately (81-0076) and uses the same regulator (81-1003) as the nitrogen cylinder.

2. Attach the flow regulator to the cylinder of zero air and the Y fitting of the gas collecting bag.
3. Close the clamp and then open the flow control valve until the gas collecting bag is approximately 3/4 full.
4. Open the clamp and allow the sample-draw pump to draw gas from the gas collecting bag. Adjust the flow regulator so the gas collecting bag remains 3/4 full.
5. After the reading stabilizes (normally 1 to 2 minutes), confirm a reading of 379 mV (or calculated value for cylinder oxygen content, if different from 20.9%) on the multimeter. If necessary, adjust the "SPAN" pot on the amplifier until the multimeter reads correctly.
6. Close the flow control knob and disconnect the ZERO AIR gas cylinder. Flatten the gas collecting bag to expel any remaining gas. If using the method of relocating sample line inlet, be sure too move the sample line inlet back to the desired monitoring location.

The transmitter is now in normal operation.

MAINTENANCE



WARNING

Perform all maintenance activities in a non-hazardous environment.

Preventive Maintenance

This schedule describes daily, monthly, and quarterly procedures to ensure the performance and durability of the transmitter.

Daily

1. Verify that the receiver indicates a reading near 0 ppm (toxic), 0% LEL (combustible) or near 21% volume (oxygen). Investigate significant changes in the display reading and signal output.
2. Confirm that the transmitter pilot light (above the flowmeter) is on.
3. Confirm that the flowmeter indicates a flow rate of approximately 0.6 SCFH. Adjust if necessary using the flow adjustment valve.

Monthly



NOTE

Some controllers have a feature that permits disabling of the alarm devices during maintenance and calibration procedures. Refer to the controller manual for information. Be sure to enable full alarm functionality after the calibration or response test procedure is complete.

To test any visual, audible and relay alarm indications by the controller during the response test, use a concentration of gas greater than the alarm setpoints.

If you have evacuation alarms or alarms that are forwarded to the fire department, be sure to notify the appropriate people before you test the alarms.

1. Confirm that the controller display reading is approximately 0 ppm (toxic) and 21% (oxygen). If not, set the fresh air signal at the amplifier to 100 mV (toxic) or 379 mV (oxygen), as described in the Start Up & Operation chapter of this manual.
2. Assemble the calibration kit and introduce the gas to the detector as described in the Calibration chapter of this manual.
3. After the reading stabilizes (normally 1 to 2 minutes), confirm that the display reading for the controller responds to the gas sample as the sample is introduced to the detector and is within $\pm 10\%$ of the desired reading. If not, perform the calibration procedure as described in the Calibration chapter of this manual.
4. Confirm that the receiver or controller alarm functions (if any) respond appropriately.
5. Turn off the calibration gas. Disassemble and store the calibration kit as described in the Calibration chapter of this manual.

Quarterly



CAUTION

Calibrate the transmitter at least once every three months. Some applications may require a more frequent calibration schedule.

Perform the calibration procedure as described in the Calibration chapter of this manual.

Troubleshooting

The section describes symptoms, probable causes, and suggested responses for problems you may encounter with the transmitter.

Fault Condition

Symptoms:

- FAULT or FAILURE indication.
- Negative reading at receiver or controller.
- Transmitter flow “FAIL” light is on.
- Transmitter flowmeter indicates less than 0.6 SCFH.

Probable Causes:

- The power supply, controller, Sample-Draw Transmitter termination PC board, amplifier or detector wiring connections are incorrect or incomplete, see Chapter 2.
- Sample-Draw Transmitter ZERO potentiometer is adjusted incorrectly, see Chapter 3.
- Low flow due to clogged filter, obstructed sample line, failed pump, etc., see Chapter 3.
- Sensor is missing, improperly installed or defective.
- Amplifier improperly set or defective.

Suggested Response:

- Check all components for proper connection to power and continuity of signal loop (see wiring diagram in Appendix B).
- Verify other components are properly connected and appear to be operating normally, check the setup of the transmitter. A fault problem can arise in either (or both) of two areas: the sample-draw subsystem or the electronic subsystem.

CHECK THE SAMPLE-DRAW SUBSYSTEM AS FOLLOWS:

1. Check that the flowmeter indicates approximately 0.6 SCFH. If this reading is low, attempt to set the correct rate using the flow adjust valve. If you cannot set the correct rate using the flow adjust valve, replace the filter in the sample line and check the sample line for obstructions or kinks.
2. If you still cannot set the correct rate using the flow adjust valve, replace the pump.
3. If the fault condition continues, contact **Thermo** GasTech for further instructions.

CHECK THE ELECTRONIC SUBSYSTEM AS FOLLOWS:

1. Confirm that the wiring to the controller terminal strip, the main board and the amplifier terminal block is complete and correct.
2. Confirm that the sensor cable is connected to the amplifier.
3. Confirm that the sensor is installed in the flow block.
4. Confirm that the sensor is plugged into the cable to the amplifier.
5. Set the fresh air signal as described in the Start Up & Operation chapter of this manual.

IF THE CONDITION CONTINUES, FURTHER ISOLATE THE PROBLEM AS FOLLOWS:

1. Disconnect the transmitter wires at the controller terminal strip and connect them to the terminals of a different channel or controller known to be operating correctly. If the fault condition clears, the controller terminal strip or main circuit board is bad. Contact **Thermo GasTech** for further instructions. If the fault continues, go to the next step.
2. Check the fresh air signal at the amplifier test jack as described in the Start Up & Operation chapter of this manual. If you can set the fresh air signal to 100 mV (toxic/combustible) or 379 mV (oxygen), then the detector amplifier and sample-draw subsystem are operating correctly. Contact **Thermo GasTech** for further instruction. If the fault condition continues, go to the next step.
3. Disconnect the detector and connect a detector known to be operating correctly. If the fault condition clears, replace the detector. You can replace the plug-in sensor as an alternate to replacing the entire detector assembly. If the fault condition continues, go to the next step.
4. Connect the detector in question to an amplifier known to be operating correctly. If the fault clears, replace the amplifier.
5. If you replaced the amplifier or detector assembly, perform the calibration procedure.
6. If the fault condition continues contact **Thermo GasTech** for further instruction.

Difficult or Unable to Calibrate, Slow or No Response

Symptoms:

- Unable to accurately calibrate the transmitter.
- Slow or no response to calibration gas during monthly response test.
- Transmitter requires frequent calibration.



NOTE

Under normal conditions, the transmitter requires calibration approximately every 3 months. Some applications may require a more frequent calibration schedule.

Probable Cause:

- Sample in gas cylinder is low, exhausted or out-dated.
- Sensor is outdated or is reaching the end of its useful life.
- Low flow due to clogged filter, obstructed sample line, failed pump, .

Suggested Response:

1. Make sure the calibration cylinder has an adequate supply of fresh gas.
2. Replace the plug-in sensor if it is outdated or shows signs of leakage or liquid contamination (investigate for source of liquid, if present).
3. Check the in-line hydrophobic filter (if installed). If the filter is installed, remove it. If the gas response changes after you remove the filter, the filter is contaminated. Replace the filter.



NOTE

Filter is not recommended for reactive gases such as Chlorine, Fluorine, etc.

4. Check the sample line for leaks by plugging the inlet to the sample line and assuring that the flowmeter float ball drops to the bottom of the flow column and that the flow “FAIL” light (above the flowmeter) is lit. If not, find and correct the leak. Unplug the sample line inlet and perform a calibration.
5. If calibration difficulties continue, contact **Thermo** GasTech for further instruction.

Replacing the Toxic or Oxygen Sensor

1. Turn off all incoming power at the power source.
2. Open the housing.
3. Unplug the cable from the sensor, (pull straight up), and pull old sensor from the flow block with fingers (if sensor appears to be stuck, pry **gently** with a small screwdriver).
4. Remove the replacement sensor from its container and **if installed** remove the spring placed between the pins marked "R" (reference) and "S" (sensing).



NOTE

Only certain toxic sensors are shipped with these shorting springs, others either do not benefit from shorting "Ref" to "Sens" pins, or may be degraded by it. Do not be concerned if the spring is missing on the new sensors.



CAUTION

Do not remove the spring until you are ready to perform the start-up procedure. The detector will take longer to stabilize if the spring is removed before start-up.

5. Press the new sensor into the cavity until it is firmly seated.
6. Reconnect the cable to the sensor.
7. Turn the power on.
8. Perform the calibration procedure described in the Calibration chapter of this manual. You can zero the detector right away, but for best results, let the detector stabilize for 1 hour before calibrating. (Oxygen sensors may be zeroed and calibrated immediately.)

Replacing the Combustible Sensor

1. Turn off all incoming power at the power source.
2. Open the housing, disconnect the three sensor wires (green, red, white) from the terminal block (R, A, C) on the amplifier.
3. Remove the sensor and adapter from the flow block by pulling straight up with your fingers. If the sensor appears to be stuck, pry **gently** with a small screwdriver.
4. Remove the four screws from the retaining plate, and slide the adapter and gasket from the sensor. Keep the gasket, adapter, and screws for the next step.
5. Attach the new sensor to the adapter, aligning the gasket between the adapter and retaining plate. Tighten all four screws.
6. Push the sensor adapter into the flow block until it is firmly seated.
7. Reconnect wires to the amplifier terminal strip as shown in Table 5-1.

Table 5-1 Combustible Detector Wiring

Combustible Detector	Amplifier Terminal Block
Green (reference)	R (terminal 4)
White (common)	C (terminal 6)
Red (active)	A (terminal 5)
No connection	O ₂ (terminal 7), J (terminals 8 & 9)

8. Test the connection by gently pulling the leads from the terminal connections.
9. Turn the power on.
10. Allow the new detector to warm up for 15 minutes, then calibrate the detector. Perform the calibration procedure described in the Calibration chapter of this manual.

Replacing the Toxic and Oxygen Amplifier

1. Turn off all incoming power at the power source.
2. Open the housing.
3. Unplug the cable from the amplifier.
4. Disconnect wires from the amplifier (green, violet).
5. Remove the two screws that secure the amplifier to the housing and remove amplifier.
6. Place the new amplifier into the housing so the holes in the housing line up.
7. Secure the amplifier to the housing using the same screws. Do not over-tighten.
8. Reconnect the wires from the main board to the amplifier terminal block, refer to table 5-2.

Table 5-2 Toxic and Oxygen Amplifier Wiring Connections

Amplifier Terminal Block	Main Board J2 Connector
+	Green
FB	Violet

9. Plug cable in to the amplifier socket.
10. Turn the power on.
11. Perform the calibration procedure described in the Calibration chapter of this manual. You can zero the detector right away, but for best results, let the detector stabilize for 1 hour before calibrating.

Replacing the Combustible Amplifier

1. Turn off all incoming power at the power source.
2. Open the housing.
3. Disconnect sensor wires from the amplifier (green, red, white).
4. Disconnect power/signal wires from the amplifier (green, blue, violet).
5. Remove the two screws that secure the amplifier to the housing and remove amplifier.
6. Place the new amplifier into the housing so the holes in the housing line up.
7. Secure the amplifier to the housing using the same screws. Do not over-tighten.
8. Reconnect the wires from the main board to the amplifier terminal block, refer to Table 5-3.

Table 5-3 Amplifier Wiring Connections

3-Point Terminal Block		6-Point Terminal Block	
Amplifier Terminal	Main Board "J2" Connector	Amplifier Terminal	Sensor Wires
1 (+)	Green	4 (R)	Green
2 (-)	Blue	5 (A)	Red
3 (FB)	Violet	6 (C)	White
-----	-----	7, 8, & 9	No Connection

9. Reconnect the sensor wires to the amplifier terminal block, refer to Table 5-3.
10. Turn the power on.
11. Perform the calibration procedure described in the Calibration chapter of this manual. You can zero the detector right away, but for best results, let the detector stabilize for 1 hour before calibrating.

Replacing the Pump

1. Turn off all incoming power at the power source.
2. Open the housing and disconnect the tubing running from the pump to the sensor flow block at the flow block end, noting where tubing goes.
3. Disconnect the pump cable (located at J3 location on the main board) from the pump and the sensor cable from both ends.
4. Remove the four screws that secure the printed circuit board to the housing, then lift and tilt the circuit board forwards at the top until the backside of the circuit board is accessible. It may be necessary to remove the shortest piece of connected tubing.
5. Remove the three barbed rubber pump mounts from the circuit board by pulling the pump gently away from the board while pushing the barb through the holes of the circuit board with a small screwdriver.
6. Transfer the connecting tubing from the old pump to the new one, into the same locations, see Figure 2-3 if necessary.
7. Insert the three barb rubber pump mounts of the new pump into the mating holes of the circuit board and pull each barb through until they fully seat and latch in place.
8. Plug the pump cable (located at J3 location on the main board) into the connector on the new pump. The connector is polarized to ensure it is plugged in properly.
9. Connect the tubing from the pump to the flow block, if necessary see Figure 2-3 for tubing location and routing. Connect any other tubing that may have been disconnected in the installation.
10. Replace the circuit board into the housing and secure it with the four screws.
11. Replace the sensor cable removed in step 3.
12. Restore power to the Sample-Draw unit and allow a few minutes to warm-up. Then perform the system checks outlined in Chapter 5.

Returning for Repair

Before you remove the transmitter from the monitoring area, first contact a **Thermo** GasTech representative.

The **Thermo** GasTech representative may guide you through certain diagnostic procedures with the transmitter in place. If you cannot correct the malfunction, the representative will assist you in returning the transmitter for repair.

Appendix
A

PARTS LIST

Table A-1 lists part numbers for the Sample-Draw Transmitter replacement parts and accessories.

Table A-1 Parts List

Part No.	Description
06-1156	Tubing, TEFLON [®] 1/4" OD x 1/8" ID
06-1253	Tubing, polyurethane, 1/4" OD x 3/16" ID
07-0009	Gasket, flange for Combustible Detector
07-6117	O-ring for Oxygen Sensor Adapter
10-0120	Retaining Screw for Combustible Sensor (4-required)
14-2112	Adapter for Combustible Sensor
14-2113	Adapter for Oxygen Sensor
17-0605	Connector, Y barb (gas collecting bag)
30-0011	Pump, sample-draw transmitter
33-0151	Filter, sample-draw transmitter
57-7045-01	Amplifier, Combustibles
57-7210	Amplifier, AsH ₃ , B ₂ H ₆ , CO, HCN, H ₂ S, NH ₃ , O ₂ , PH ₃ , SiH ₄ , SO ₂
57-7210-01	Amplifier, Cl ₂ , ClO ₂ , F ₂ , HF, NO ₂ , O ₃
57-7210-02	Amplifier, HCl, NO
61-0121-01	Sensor, combustible
65-1061	Sensor, oxygen (O ₂)
65-2417	Sensor, sulfur dioxide (SO ₂)
65-2425-01	Sensor, carbon monoxide (CO)
65-2425-02	Sensor, hydrogen sulfide(H ₂ S)
65-2431-01	Sensor, chlorine (Cl ₂), fluorine (F ₂)
65-2431-02	Sensor, hydrogen cyanide (HCN)
65-2431-03	Sensor, nitric oxide (NO)

Table A-1 Parts List (Continued)

Part No.	Description
65-2431-04	Sensor, hydrogen chloride (HCl)
65-2431-05	Sensor, hydrogen fluoride (HF)
65-2431-07	Sensor, ammonia (NH ₃)
65-2431-08	Sensor, arsine (AsH ₃), diborane (B ₂ H ₆), phosphine (PH ₃), silane (SiH ₄)
65-2431-09	Sensor, ozone (O ₃)
65-2431-10	Sensor, nitrogen dioxide (NO ₂)
65-2431-11	Sensor, chlorine dioxide (ClO ₂)
71-0114	Sample-Draw Transmitter Operator's Manual
81-0065	Cylinder, CO-in-air (100 ppm)
81-0076	Cylinder, Zero-emission air
81-0078	Cylinder, 100% nitrogen (N ₂)
81-0151	Cylinder, H ₂ S-in-N ₂ (25 ppm)
81-0170	Cylinder, SO ₂ -in-N ₂ (5 ppm)
81-0175	Cylinder, NO-in-N ₂ (25 ppm)
81-0180	Cylinder, NO ₂ -in-N ₂ (5 ppm)
81-0188	Cylinder, SiH ₄ -in-N ₂ (5 ppm)
81-0190	Cylinder, Cl ₂ -in-N ₂ (5 ppm) ¹
81-0191	Cylinder, NH ₃ -in-air (25 ppm)
81-0192	Cylinder, HCN-in-N ₂ (10 ppm)
81-0193	Cylinder, PH ₃ -in-N ₂ (0.5 ppm) ²
81-0194	Cylinder, HCl-in-N ₂ (10 ppm)
81-1003	Regulator, CO, O ₂ , Combustible gases
81-1051-01	Regulator, toxic gases (except Cl ₂ & HCl)
81-1062	Regulator, Cl ₂ , HCl
81-1131	Gas collecting bag, vinyl
81-1132	Clamp, tubing (gas collecting bag)
81-1133	Gas collecting bag, TEDLAR™, reactive gas
81-1134	TEDLAR™ gas collecting bag kit

Table A-1 Parts List (Continued)

Part No.	Description
81-6414-01	Calibration kit, H ₂ S (25 ppm)
81-6414-02	Calibration kit, Cl ₂ (5 ppm) ¹
81-6414-03	Calibration kit, HCl (10 ppm)
81-6414-04	Calibration kit, HCN (10 ppm)
81-6414-05	Calibration kit, NH ₃ (25 ppm)
81-6414-06	Calibration kit, PH ₃ (0.5 ppm) ²
81-6414-07	Calibration kit, NO (25 ppm)
81-6414-08	Calibration kit, NO ₂ (5 ppm)
81-6414-09	Calibration kit, SO ₂ (5 ppm)
81-6414-10	Calibration kit, SiH ₄ (5 ppm)
81-6415-01	Calibration kit, LEL, Methane
81-6415-02	Calibration kit, LEL, Hydrogen
81-6415-03	Calibration kit, LEL, Propane
81-6415-04	Calibration kit, LEL, Hexane
81-6415-05	Calibration kit, PPM, Methane
81-6415-06	Calibration kit, PPM, Hexane
81-6415-07	Calibration kit, PPM, Hydrogen
81-6415-08	Calibration kit, O ₂ (100% N ₂)
81-6415-09	Calibration kit, CO (100 ppm)
82-0005	Screwdriver, adjustment
<p>1. Appropriate also for fluorine (F₂) and hydrogen fluoride (HF) sensors 2. Appropriate also for arsine (AsH₃) and diborane (B₂H₆) sensors.</p>	

Appendix B

EXTERNAL WIRING INSTRUCTIONS

Appendix B shows the Sample-Draw Transmitter external wiring instructions.

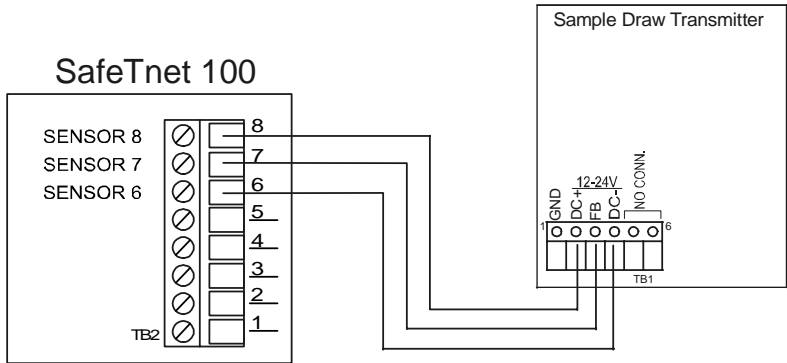

Figure B-1 SafeTnet 100 External Wiring

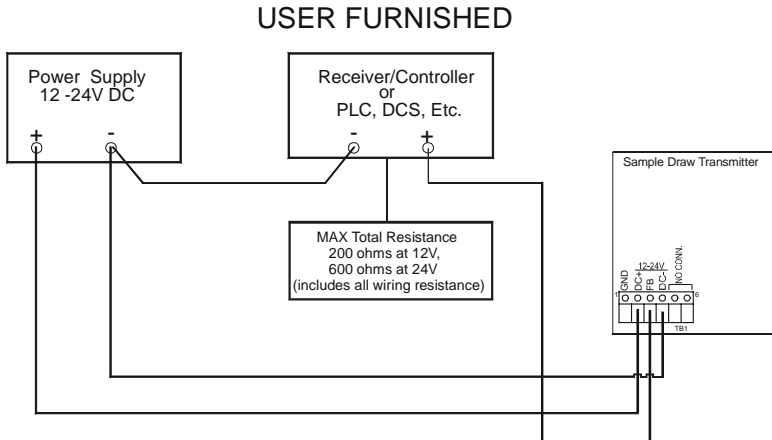
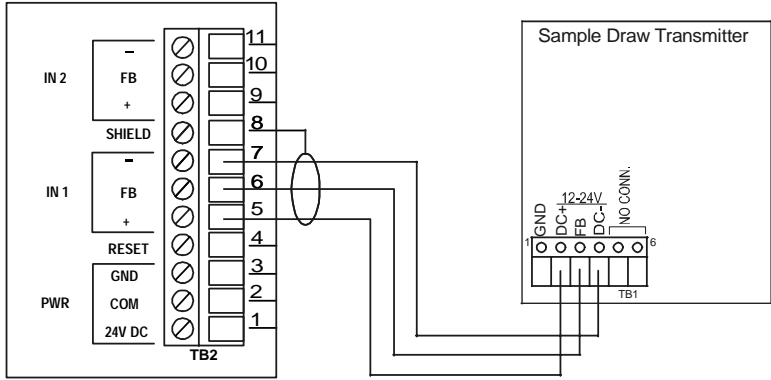
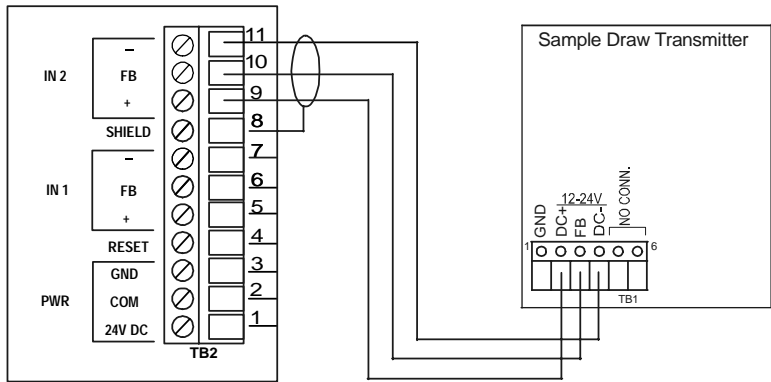

Figure B-2 User Furnished External Wiring

STN 2000, 210 and 410



Channel 1



Channel 2 (optional)

Figure B-3 SafeTnet 2000, 210 and 410 External Wiring

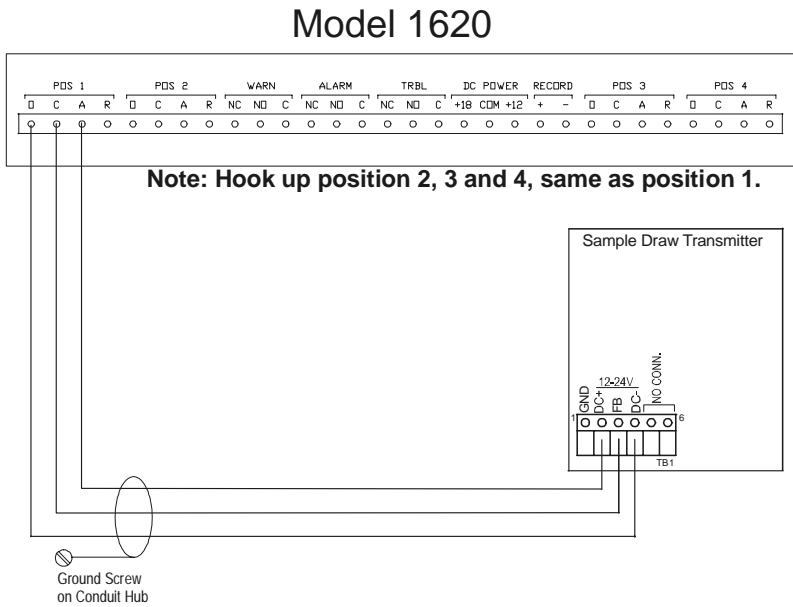
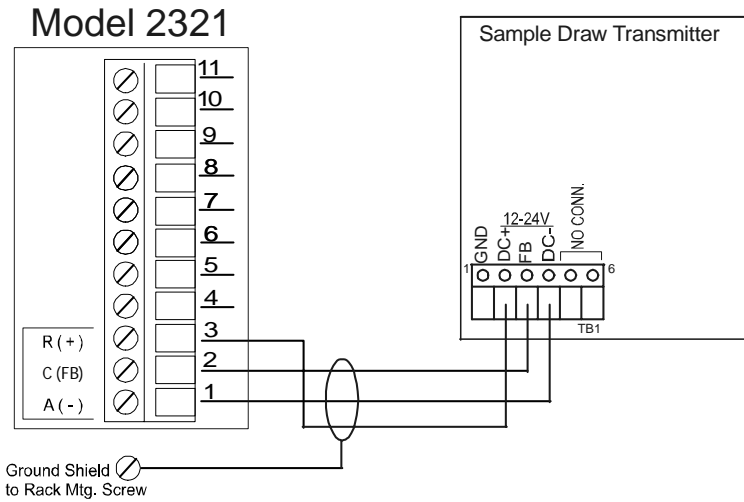

Appendix C

CALIBRATION RESPONSE CHARTS

Appendix C shows the Sample-Draw Transmitter calibration response charts.

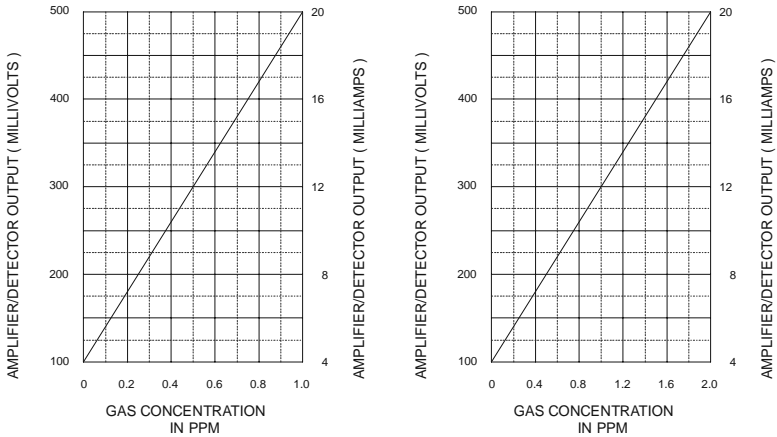

Figure C-1 Calibration Response Charts for 0-1 and 0-2 ppm

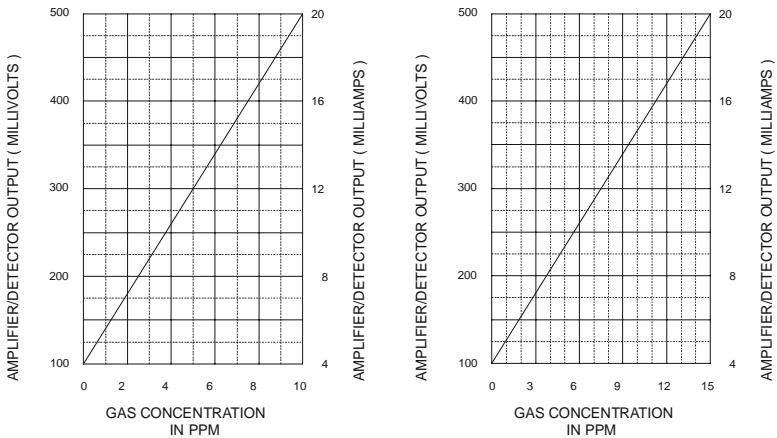

Figure C-2 Calibration Response Charts for 0-10 and 0-15 ppm

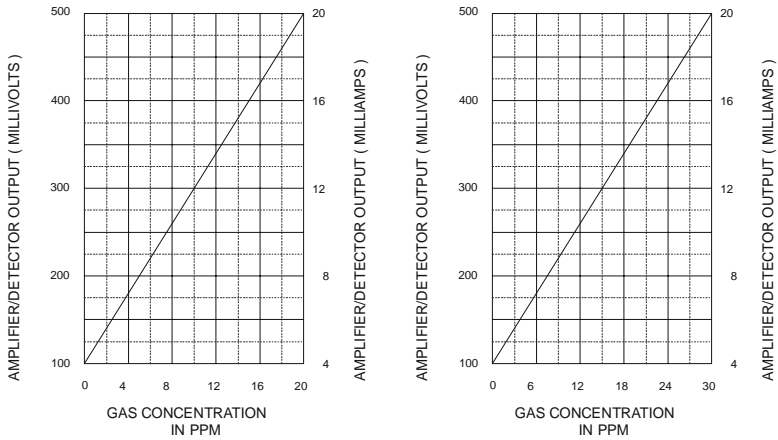

Figure C-3 Calibration Response Charts for 0-20 and 0-30 ppm

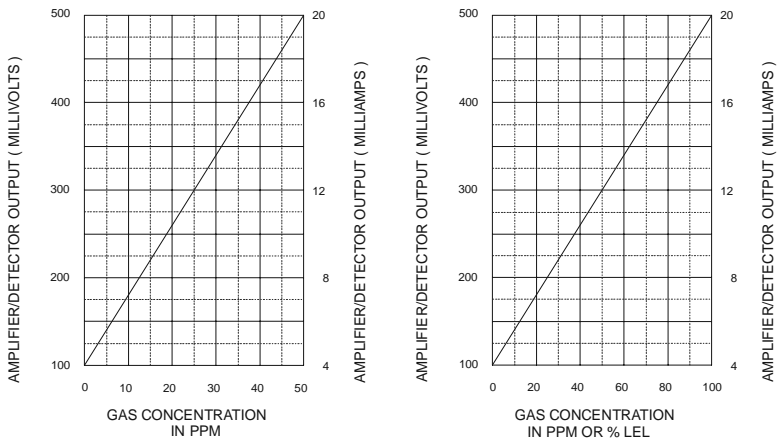

Figure C-4 Calibration Response Charts for 0-50 ppm and 0-100 ppm or % LEL

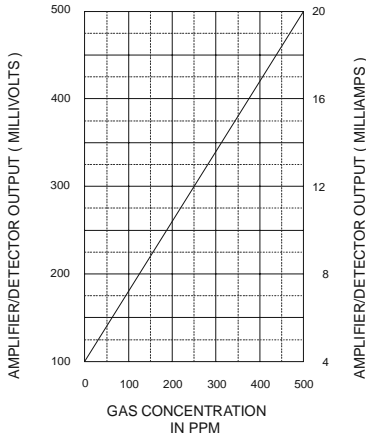

Figure C-5 Calibration Response Charts for 0-500 ppm

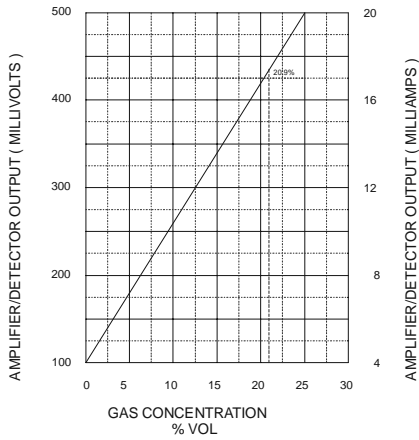

Figure C-6 Calibration Response Charts for 0-30% by volume

