

TVOC User Manual V2.6

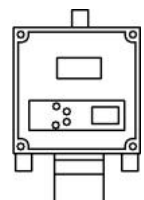

DECLARATION OF CONFORMITY

Manufacturer: Ion Science Ltd, The Way, Fowlmere, Cambridge, SG8 7UJ, UK

Product: TVOC

Product Description: An intrinsically safe fixed continuous monitor comprising of a photo-ionisation detector for detecting and measuring volatile organic compounds with a 4-20mA output

Directive 94/9/EC **ATEX**

Identification:  II 2G Ex ia IIC T4 (-20°C mTa m+50°C)

Notified Body: Baseefa Ltd, 1180, Buxton, UK

EC Type Examination Certificate(s)

Baseefa05ATEX0277 latest supplement Baseefa03ATEX742/2 issued 24th November 2008

IECEX BAS 06.0057 latest revision no.1 issued 20th November 2008

Standards

BS EN 60079-0:2006 Electrical Apparatus for Potentially Explosive Atmospheres . General Requirement

BS EN 60079-11:2007 Explosive Atmospheres - Equipment Protection by Intrinsic Safety \pm q

BS EN 61010-1:2001 Safety requirements for electrical equipment for measurement, control and laboratory use . General requirements

Directive 2004/108EC Electrical Equipment – Electromagnetic Compatibility (EMC)

BS EN 50270:1999 Electromagnetic compatibility. Electrical apparatus for the detection and measurement of combustible gases, toxic gases or oxygen

BS EN 61000-6-6:2001 Electromagnetic Compatibility (EMC) Generic standards. Emission standard for residential, commercial and light industrial environments

With respect to BS EN 50270:1999, the TVOC achieves performance criteria A (the apparatus continues to operate as intended before and after the test) except at spot frequencies where it achieves criteria B (the apparatus continues to perform after the test but during the test a degradation of performance is seen). See technical specification for details.

Other Standards

BS EN ISO 9001:2000 Quality Management Systems . Requirements

BS EN 13980:2002 Potentially Explosive Atmospheres . Application of Quality Systems

On behalf of Ion Science Ltd, I declare that, on the date this product accompanied by this declaration is placed on the market, the product conforms to all technical and regulatory requirements of the above listed directives.

Name: Mark Stockdale

Position: Technical Director

Signature:



Date: 20th November 2008

Contents	Page
1 – Statements	5
2 – Introduction to TVOC	6
3 – Packing List	7
4 – TVOC Set up	8
Selector pins	8
Cycle times	9
5 – Installation	10
Location	10
Mounting	11
Cable requirements	12
Power requirements	12
Non Intrinsically Safe (IS) applications	12
Intrinsically Safe (IS) applications.	14
Initial calibration	16
6 – Operation	17
Start up.	17
Cycle times	17
LED's	18
Selector pins	18
Calibration mode	19
7 – Calibration	20
Calibration routine	20
Setting the zero	21
Setting the gas tolerance	22
Setting the span	22
Display lamp life	23
8 – Maintenance	24
Cleaning and replacing the PID lamp	24
Fuse rupture and replacement	27
Lamp warranty statement	27
9 – Diagnostics	28
10 – Spare parts	30
11 – Technical Specifications	31

2 Introduction to TVOC

TVOC is a fixed continuous monitor for the detection and measurement of total volatile organic compounds, which can be dangerous from both a poisoning and explosive perspective. Total VOC's are detected using PID (Photoionisation Detection) technology).

TVOC has a number of user selectable features which define its operation and will be application dependent. The user can define the detection ranges or 0.01 - 10ppm, 0.1 – 100 ppm or 1 – 1,000 ppm (Default); detection units, either ppm or mg/m³; and the duty cycle time i.e. the frequency that the instrument takes a measurement. Duty cycles are explained in more detail in section 4, TVOC set up, and section 6 Operation.

IMPORTANT: if the 10ppm range is selected the TVOC will require a calibration using 10ppm Isobutylene before use.

The default settings of TVOC are:

Detection range	–	0.1 – 1000 ppm
Units	-	ppm
Duty cycle	-	5 seconds ON / 55 seconds OFF

TVOC gives a continuous 4 – 20 mA output which can be integrated into a DCS control system to give an indication of VOC levels in the operating environment.

In addition to the 4 – 20 mA output TVOC has an LCD display showing gas concentration and 4 colour LED's. LED functions are as follows:

Green	-	is an indicator of TVOC's working status
Red	-	is the fault indicator
Yellow x 2	-	are calibration status indicators

Please see section 7 Calibration for more information on LED status.

For installation requirements please refer to sections 5 and 10 of this manual. For Intrinsically Safe (IS) installations please also refer to the TVOC ATEX certificate for further details. Before attempting an installation, please fully read and understand this user manual.

TVOC does require regular calibration onsite please see section 7 Calibration for information. TVOC calibration mode is accessed via a magnetic read switch system.

The TVOC intrinsic safety rating permits its deployment in all hazardous areas of the quoted (or less demanding) rating. That is, in areas where explosive gases (of Group IIA, IIB and IIC) are intermittently present (Zone 1) within an ambient temperature range of -20°C and +60°C.

3 Packing List

All items of equipment shipped by Ion Science Ltd are packed in suitable containers and enclosed in a shock absorbing filling which affords a considerable degree of protection against physical damage.

Contents should be carefully removed and checked against the packing list. Any discrepancies between the contents and the packing list must be reported to Ion Science Ltd within 10 days of receipt of shipment. Ion Science cannot be held responsible for shortages not reported with in the period.

Standard TVOC instrument

Item	Description	Qty
1.	TVOC instrument	1
2.	TVOC Manual	1

TVOC Calibration Tool Kit

Item	Description	Qty
1.	Calibration magnet	1
2.	Calibration adaptor	1
3.	Calibration connector	1
4.	Aspirator	1
5.	Carbon filter	1
6.	Allen keys	1

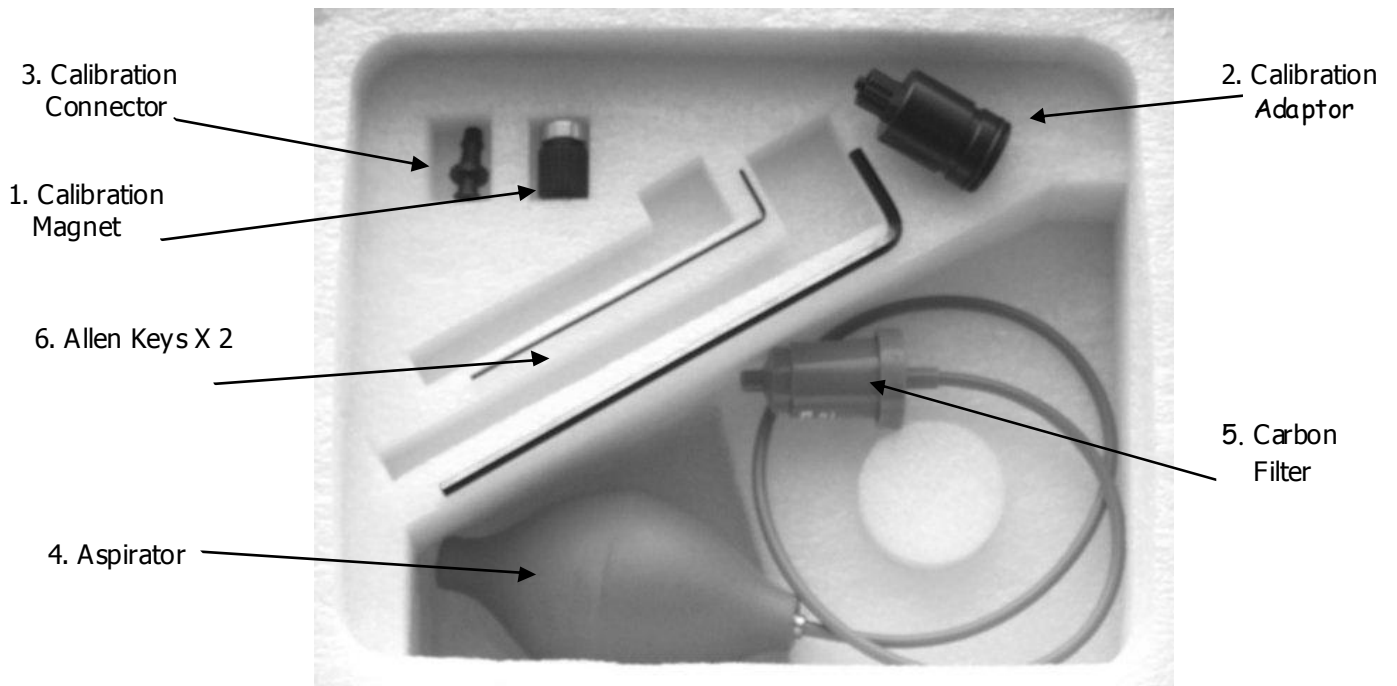

4 TVOC Setup

4.1 Selector Pins

TVOC has a number of settings that can be selected by the user via a row of 4 selector pins mounted on the reverse side of the main PCB. Diagram 4.1 shows the location of the functional selector pins labelled - A, B, C & D.

The selector pins absence or presence determines the chosen setting.

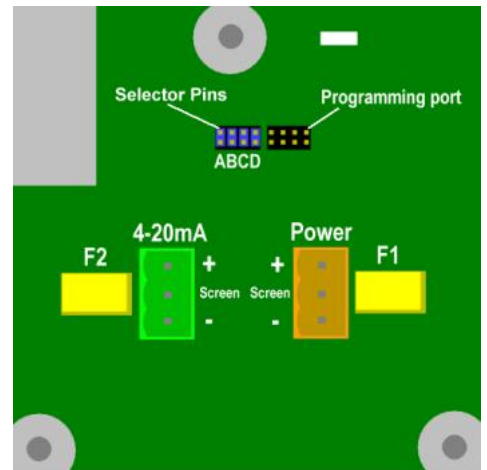

Diagram 4.1

TVOC is shipped with all 4 selector pins fitted as shown in diagram 4.2.

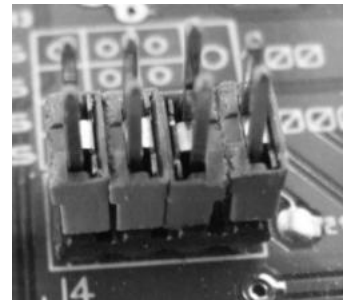

Diagram 4.2

Diagram 4.3 demonstrates the removal of 1 selector pin.

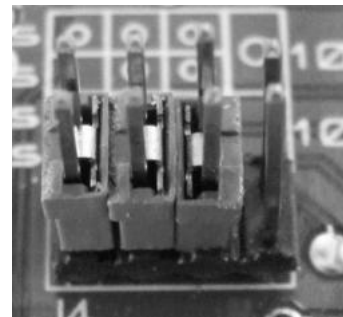

Diagram 4.3

4 TVOC Setup

The following table shows the selector pin combinations and the corresponding function.

- ✓ = Selector pin fitted
- ✗ = Selector pin removed

Selector pin				Range	Displayed units
A	B	C	D		
✓ (n/a)	✓	✓	✓	1000	ppm (Default)
✓ (n/a)	✓	✗	✓	100	ppm
✓ (n/a)	✗	✓	✓	10	ppm
✓ (n/a)	✓	✓	✗	2280	mg/m ³
✓ (n/a)	✓	✗	✗	228	mg/m ³
✓ (n/a)	✗	✓	✗	22.8	mg/m ³

Selector pin 'B' and 'C' selects the ranges	-	10ppm, 100ppm or 1,000ppm
Selector pin 'D' selects the units	-	ppm' or 'mg/m ³
Selector pin 'A'	-	Currently not used

IMPORTANT: if the 10ppm range is selected the TVOC will require a calibration using 10ppm Isobutylene before use. (See the calibration section of this manual)

- NOTE:
- * TVOC is shipped with all selector pins fitted as standard
 - * TVOC only reads the selector pin settings when power is connected.
Always ensure power is disconnected from TVOC before changing setting or carrying out maintenance.
 - * Never place selector pins on the programming port connector.
 - * Ensure static build up is discharged before touching components.

4.2 Duty Cycle

The TVOC has a variable duty cycle whereby the lamp is ON for 5 seconds and then OFF for a user set period between 0 to 5 minutes in 1 second increments. The 4 – 20 mA output is updated at the end of each cycle. As standard the TVOC duty cycle is 1 minute – the lamp is ON for 5 seconds and OFF for 55 seconds. The lamp OFF time is fully adjustable by the user. Please see section 6.1 of this manual for full instructions.

5 Installation

5.1 Location

There are many variables involved in defining the optimum location for a gas detector. Obvious though it may sound, the most important rule is:

- A detector will not detect gas unless gas actually reaches the detector.

TVOC should be mounted in the location most likely to detect gas.

- TVOC must be mounted vertically with the sensor underneath the case. This avoids dust and debris blocking the access to the detector cell.
- Mount TVOC higher if detecting VOC gases that are lighter than air or lower if detecting VOC gases that are heavier than air (but never on the floor). This should maximise detection.
- Mount TVOC in an area that has good air circulation. Restricting natural air current may result in delayed detection.
- Never mount TVOC in direct sunlight or over a heat source such as a radiator. This may cause TVOC to exceed its certified working range.
- Do not mount TVOC where it's subjected to rain fall, water, aerosols, mist or heavy condensation.
- Mount TVOC in areas that are easily accessible for servicing.
- Percentage variations in the composition of air (78% Nitrogen, 21% Oxygen and 1% Argon) may affect the detected signal.

Please refer to the technical specifications of the instrument in Section 10 of this manual before beginning a TVOC installation.

5 Installation

5.2 Mounting

Dimensions for mounting TVOC are given in Diagram 5.2.1 below.

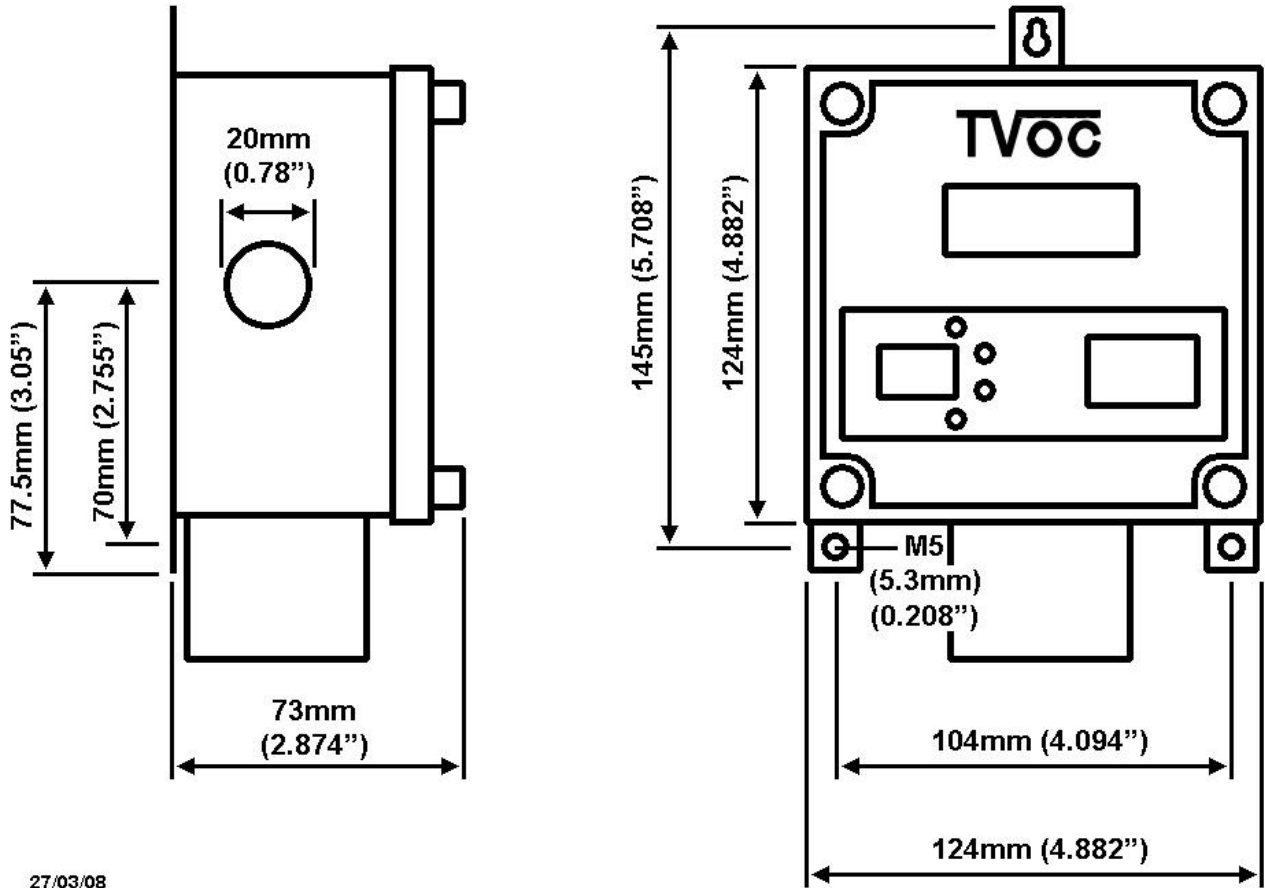

27/03/08

Diagram 5.2.1

NOTE: The TVOC case can be used as a template when marking out fixing holes but do not drill through the fixing holes.

5 Installation

5.3 Cable requirements

Ion Science Ltd suggests using screened cables for both power in and signal out. Cable screens must be terminated at the TVOC enclosure using EMC cable glands.

5.4 Power requirements

5.4.1 Non Intrinsically Safe (Non IS) applications:

Input power 5 - 28Vdc. 65mA max.
 4-20mA power 8-35Vdc. 22mA

4 Wire System

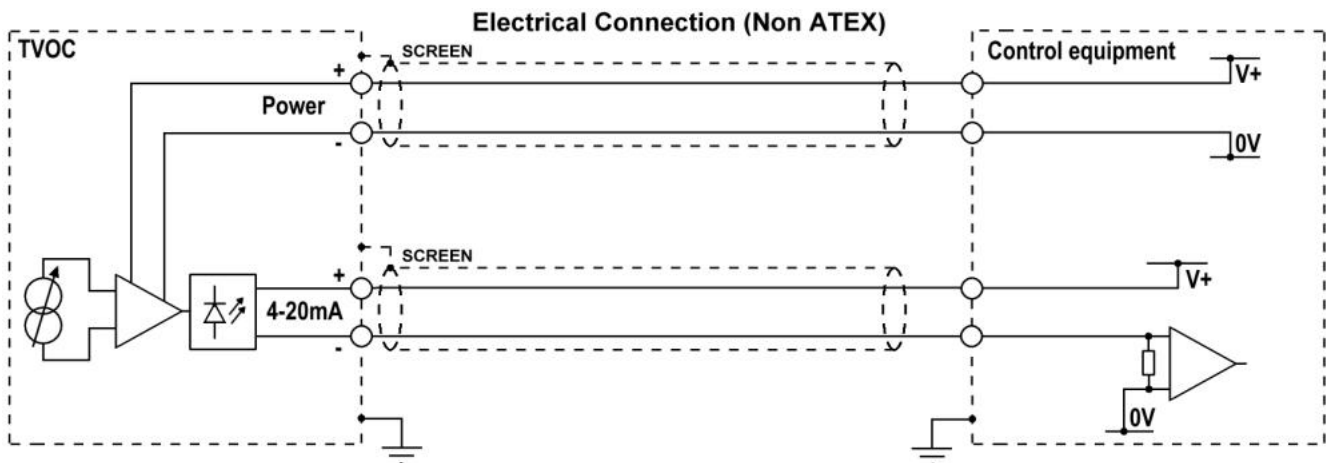
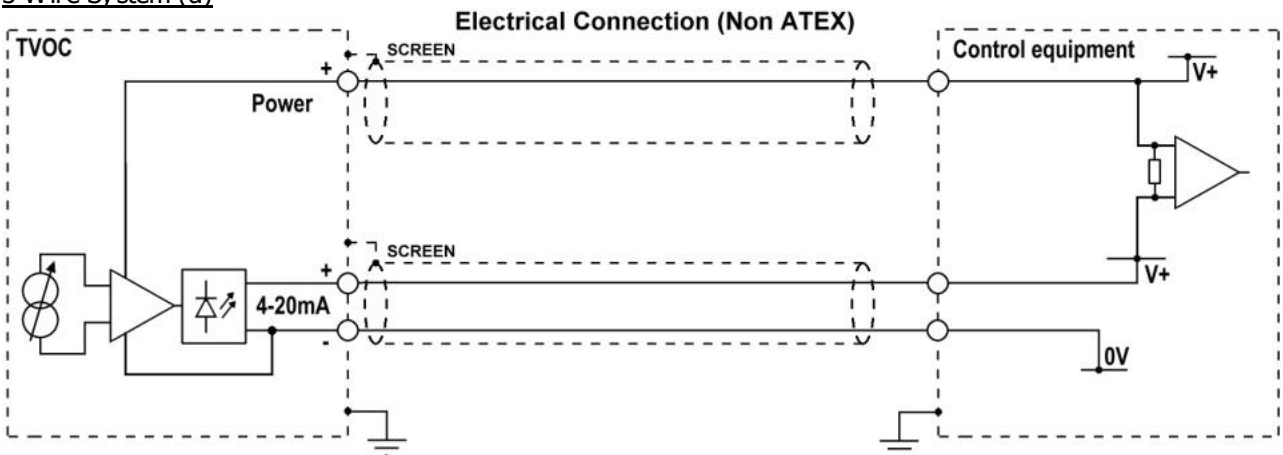

Diagram 5.4.1

3 Wire System (a)



5 Installation

3 Wire System (b)

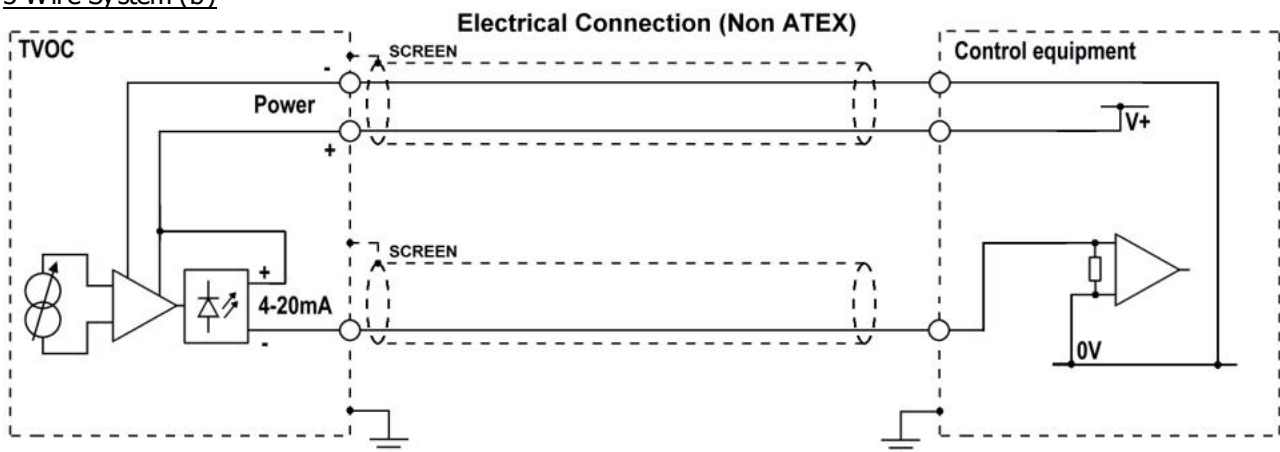

!WARNING!

Non Intrinsically Safe (Non IS) applications

When the unit is installed with a non IS rated power supply the IS details on the front of the unit are not appropriate for the system. The IS label should be covered up or blocked out. This will prevent safety discrepancies and or mis-use in the future should the equipment be moved or the site be re-defined as a hazardous area.

5 Installation

5.4.2 Intrinsically Safe (IS) applications: Entry parameters

Input power	$U_i = 18V$	$I_i = 800mA$	$P_i = 1.2W$	$C_i = 0\mu F$	$L_i = 0mH$
4-20mA power	$U_i = 30V$	$I_i = 200mA$	$P_i = 1.2W$	$C_i = 0\mu F$	$L_i = 0mH$

For information only please see ATEX certificate before installation

Ion Science Ltd suggest using the following Zener Barriers for IS approved applications. Use competent installation engineers and ask them for installation and application advice.

POWER SUPPLY: Suggested barriers for INLET power supply

Manufacturer	Manufacturers pt no.	Type	Cable length estimate
Pepperl+Fuchs	Z715	Zener barrier	~ 1115 meters
Pepperl+Fuchs	KFD2-SD2-EX1.1065	Galvanic isolator	~ 1217 meters
MTL	7715P+	Zener barrier	~ 772 meters
Stahl	9901/01-158-270-101	Zener barrier	~ 500 meters
Stahl	9143/10-156-065-10	Galvanic isolator	

SIGNAL OUTPUT: Suggested barriers for 4-20mA OUTLET

Manufacturer	Manufacturers pt no.	Type
Pepperl+Fuchs	Z728	Zener barrier
Pepperl+Fuchs	KFD2STC4-Ex1	Galvanic isolator
MTL	MTL7787	Zener barrier
MTL	MTL5042	Galvanic isolator
Stahl	9001/01-280-110-141	Zener barrier
Stahl	9160/13-11-11	Galvanic isolator

NOTE

- All cable lengths are estimated for zone 1 IIC installation of the equipment
- Using 1mm² C.S.A conductor S.T.P cables with capacitance per meter of 250pF/m, L/R ratio of 25uH/ Ω conductor resistance at 20°C of 18.4 Ω /km.
- Calculation assumes cables are at 50°C.

WARNING! Intrinsically Safe (IS) applications

- Units should not be powered using non IS power supplies prior to installation in an IS application.
- If non IS power is supplied the unit will require inspection by Ion Science Ltd or an Ion Science Approved Service Centre prior to installation in an IS application.
- TVOC fuses may not be replaced in the field.
- If a fuse is blown TVOC will require inspection by Ion Science Ltd or and Ion Science Approved Service Centre before it is used in an IS application.

5 Installation

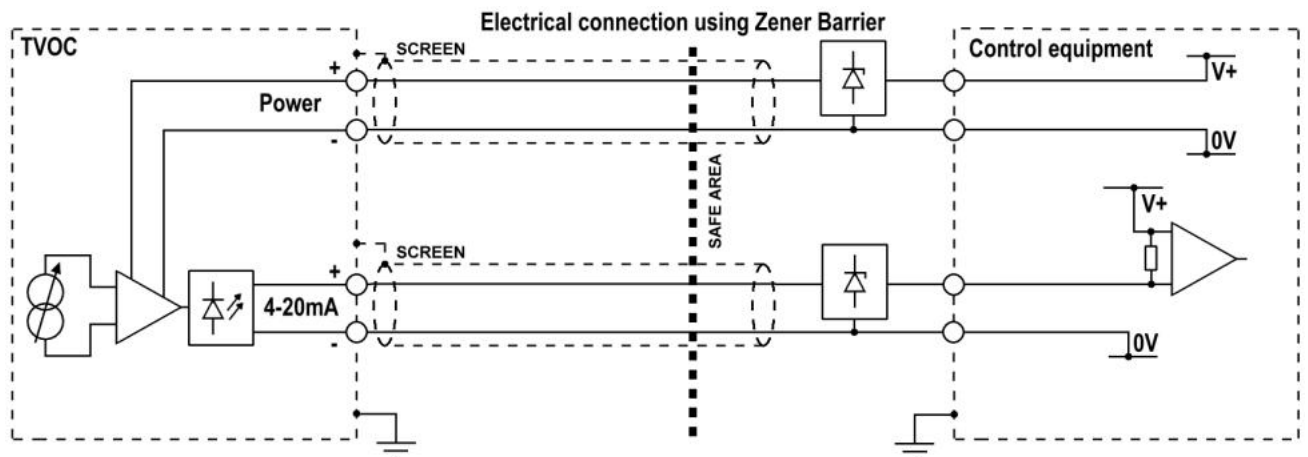

Diagram 5.4.2.1 Control equipment sensing 4 – 20 mA at supply rail

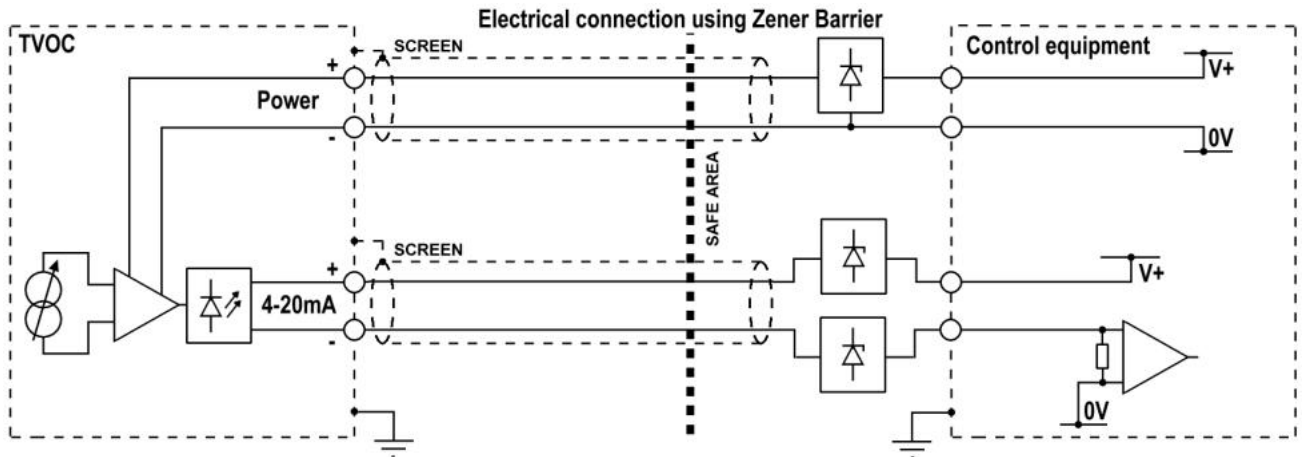

Diagram 5.4.2.2 Control equipment sensing 4 – 20 mA to 0V

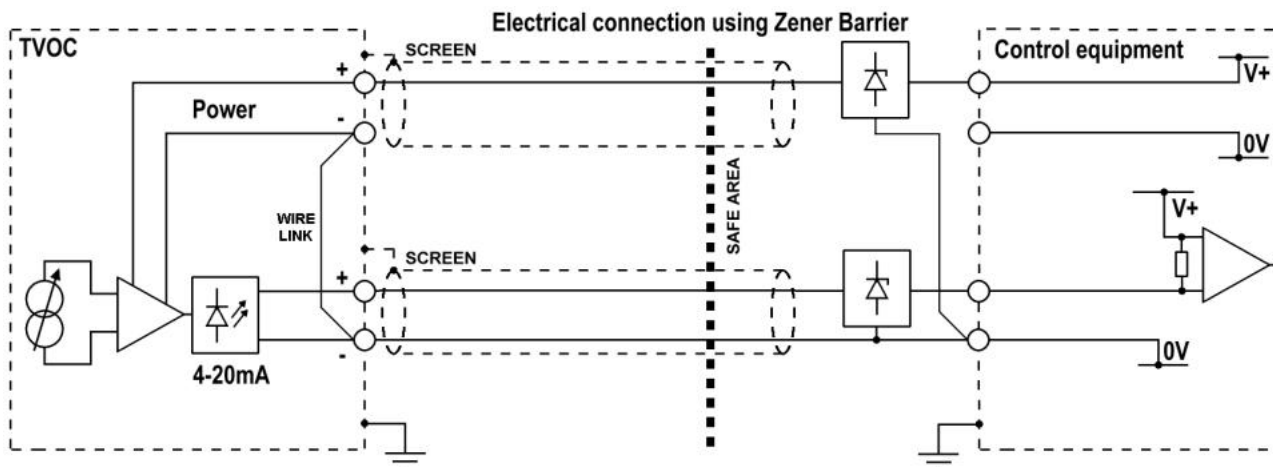

Diagram 5.4.2.3 Control equipment sensing (3 wire)

5 Installation

5.5 Initial calibration

TVOC is calibrated at Ion Science before dispatch using 100ppm Isobutylene. However if you wish to calibrate your TVOC once it is installed Ion Science recommends that the TVOC is left to run on its chosen settings (see Section 4 TVOC Set up) for 24 hours before an initial calibration is carried out, to allow the instrument to settle into the working environment.

6 Operation

6.1 Start Up

After electrical power is connected, TVOC runs through a 'Start up' routine, which lasts for approximately 1 minute. During this 'Start up' routine TVOC demonstrates the following characteristics:

- * The LCD screen displays the software version number
- * The GREEN LED flashes
- * The 4 – 20 mA output is set to 4 mA (0.0 ppm)

NOTE: If the 0-10ppm range is selected the TVOC will require calibration using 10ppm Isobutylene before user (See the calibration section of this manual)

During this 'Start-up' time the user can adjust the lamp OFF time as referred to in Section 4.2. This time can be adjusted from 0 to 5 minutes in 1 second increments.

6.2 Cycle times

To extend PID lamp life and the time between servicing, TVOC includes a variable duty cycle, (see section 4.2) whereby the lamp is switched ON and OFF. The length of time between servicing and calibration is increased where longer OFF times are selected. However the length of time between servicing also depend on ambient air quality, the higher VOC concentration detected by the instrument then the shorter the time between servicing.

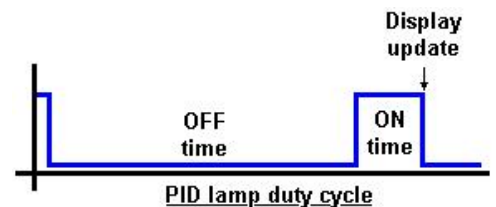

6.2.1 Adjusting the lamp OFF time

There are two stages to adjusting the lamp OFF time. The first stage adjusts the seconds (0-59) and the second stage adjusts the minutes (0-5). To adjust the lamp OFF time the magnetic switch must be activated during the 'Start-up' time.

NOTE: Please read this entire procedure before attempting to adjust the lamp OFF time.

1 – During the 1 minute 'Start up' routine place the calibration magnet over the top right hand corner of the Ion Science logo. Two numbers on the LCD screen will flash.



2 - This indicates the lamp OFF time in seconds.

3 – Placing the calibration magnet back over the logo will cause the number to rotate between 0 and 59 seconds. Remove the magnet when the desired time is displayed.

4 – After 5 seconds the display will show another two numbers and flash.

5 – This indicates the lamp OFF time in minutes.

6 – Again place the calibration magnet over the logo to rotate the numbers between 0 and 5 minutes. Remove the magnet when the desired time is displayed.



6 Operation

- 7 - After 5 seconds the entire output frequency is displayed.
- 8 - After a further 5 seconds the set frequency will be set in the TVOC memory.
- 9 - TVOC then continues through the standard start-up routine.



If you are unhappy with the update frequency you have set you can adjust the time by placing the calibration magnet over the logo during the 5 seconds after the total time has been shown (point 8 above).

NOTE: The total duty cycle time includes the 5 seconds lamp ON time. Therefore if you wish your total duty time to be approximately 2 minutes set the lamp OFF time to 1 minute 55 seconds.

At the end of the 'Start up' routine TVOC will enter the selected monitoring routine.

6.3 LED's

The GREEN LED indicates TVOC's working status

ON	Indicates the PID lamp is OFF
Flashing	Indicates the PID lamp is ON

The RED LED indicates Fault status

ON	Indicates TVOC cannot function correctly. The 4-20mA output drops to 3.5mA. URGENT attention is required.
Flashing	Indicates the last calibration carried out was outside expected limits. The instrument will continue working but service is required.

Please see Section 7 Calibration for YELLOW LED status.

6.4 Selector pins

TVOC has a range of options that are selected via the selector pins on the back of the main PCB (please see Section 4 TVOC Set up).

The options are shown below with the defaults highlighted in bold:

1-1000ppm	or	0.01 - 10 ppm or 0.1 - 100 ppm
ppm units	or	mg/m ³ units

6 Operation

6.5 Calibration mode

TVOC calibration mode can be accessed using the calibration magnet supplied in the TVOC calibration tool kit (Part number: A-845214).

To enter calibration place the magnet over the top right of the Ion Science Logo until the state changes (i.e. an LED illuminates and/or the display changes).

Ensure the magnet is withdrawn away from the magnetic switch by at least 1 cm once a change has occurred.

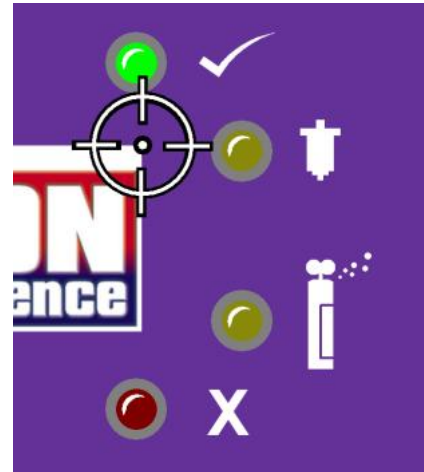

6.6 Calibration gases

TVOC has three (3) ranges that can be selected however the 0-10ppm range requires the instrument is calibrated by the user before use. The 0-100ppm and the 0-1000ppm ranges can initially run using the Factory calibration carried out during the instruments manufacture, however because the 0-10 ppm range is more sensitive and more susceptible to environmental and system tolerances the instrument must be calibrated using 10ppm Isobutylene before use.

If the 0-10 ppm range is selected TVOC will display the following screen to indicate that a calibration is required before it can be used. Follow the calibration instructions before use.



7 Calibration

7.1 Calibration routine

Ion Science recommends calibrating TVOC after any maintenance or lamp cleaning is carried out and on a 3 monthly basis to ensure TVOC is working to specification.

NOTE: Please read this entire calibration procedure before attempting a calibration.

TVOC calibration has 4 stages:

1. Setting the ZERO (Using clean gas via carbon filter)
2. Setting the gas tolerance (90 – 110 ppm Isobutylene on 0-100 ppm and 0-1000 ppm ranges)
(9 - 11ppm Isobutylene on the 0-10ppm range)
3. Setting the SPAN (Using the SPAN gas)

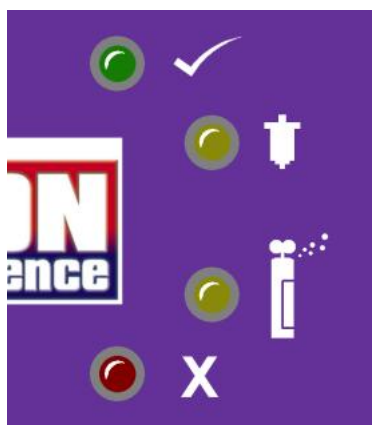

**GREEN
STATUS LED**

ZERO LED

SPAN LED

FAULT LED

7 - Calibration

7.2 Setting the ZERO

- 1 – Place the calibration magnet over the top right hand corner of the Ion Science logo to enter calibration mode. The ZERO LED will illuminate and the GREEN STATUS LED will extinguish.
- 2 – Remove the calibration magnet
- 3 – Insert the calibration adaptor into the sensor cap, attach the carbon filter to the calibration adaptor. The carbon filter should be attached to the hand aspirator.
- 4 – Again place the calibration magnet over the logo. The ZERO LED will flash, during this stage TVOC displays a direct millivolt (mV) output from the PID sensor.

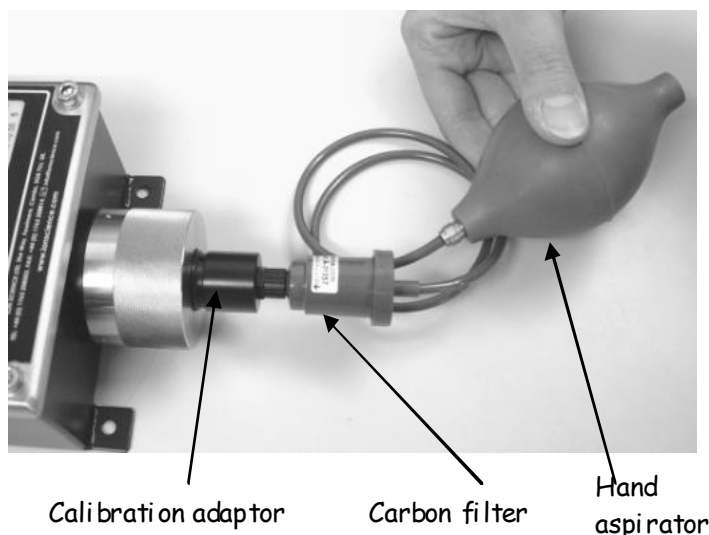

- 5 - Slowly and repeatedly squeeze the hand aspirator to push clean air through the carbon filter and past the PID sensor. The ZERO LED will stop flashing after approximately 2 minutes.
- 6 – Now remove the equipment except for the calibration adaptor.

NB During the Zeroing process the mV reading on the display must reduce to below 30 mV to pass the ZERO calibration stage.

An acceptable ZERO calibration level will result in the illumination of the GREEN LED.

An unacceptable ZERO calibration level will result in the illumination of the RED LED. Should this occur the previous zero calibration level will be used.

